

+ BALL SCREWS - INTERCHANGEABLE



Ball Screws – Interchangeable

As one of the world's leading manufacturers of rolling bearings, linear technology components and steering systems, we can be found on almost every continent – with production facilities, sales offices and technology centres – because our customers appreciate short decision-making channels, prompt deliveries and local service.



The NSK company

NSK commenced operations as the first Japanese manufacturer of rolling bearings back in 1916. Ever since, we have been continuously expanding and improving not only our product portfolio but also our range of services for various industrial sectors. In this context, we develop technologies in the fields of rolling bearings, linear systems, components for the automotive industry and mechatronic systems. Our research and production facilities in Europe, Americas and Asia are linked together in a global technology

network. Here we concentrate not only on the development of new technologies, but also on the continuous optimisation of quality – at every process stage.

Among other things, our research activities include product design, simulation applications using a variety of analytical systems and the development of different steels and lubricants for rolling bearings.

Trademarks on this catalogue

All NSK product and service names listed in this catalogue are trademarks or registered trademarks of NSK Ltd.

NSK developed the 'Ball screws – interchangeable' series based on many years of experience and with the help of the most advanced technology. The series complies 100% with DIN 69051. The spindle nut and spindle shaft are available separately and are universally exchangeable. The new 'Ball screws – interchangeable' series features an extreme reduction in noise and can be used in high-speed applications. As an option, the NSK K1 lubrication unit, proven in use over many years, can be integrated.

Features

- › Nut and shaft are completely interchangeable
- › 100% DIN-compliant
- › High-speed/low-noise nut design

Remarkable improvement in sealing performance (introduction of grease-retaining seal)

- › Grease retention capabilities substantially enhanced
- › Assists clean environment maintenance due to minimum grease scattering
- › Superb sealing capabilities in contaminated environments

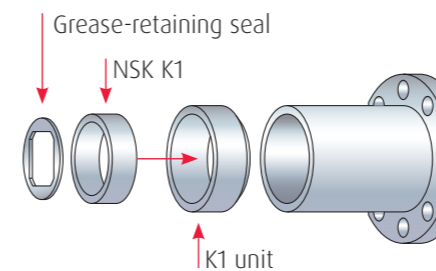

Maintenance-free long-term with NSK K1 lubrication unit

- › NSK K1 is a lubrication unit which combines oil and resin in a single unit
- › The porous resin contains a large amount of lubrication oil
- › Touching its surface to the raceway of a shaft close to the NSK K1 contact point constantly supplies fresh oil which seeps out of the resin
- › NSK K1 lubrication has been accepted in many industrial fields since 1996

Accuracy grade

- › An accuracy grade of Ct7 is available

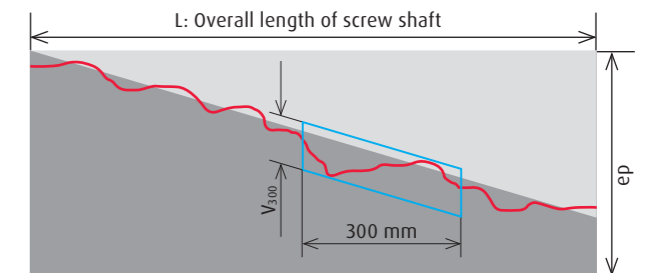

Grade	Ct7
ep: Tolerance on specified travel	$ep = \pm \frac{L}{300} \cdot V_{300}$ (mm) L: Overall length of screw shaft
Travel variation in a 300 mm range (anywhere in useful travel)	0.052 mm
Repeatability	0.003 mm
Clearance	0.020 mm to light preload

Options

- › Support unit (sold separately)
- › NSK provides the support bearing units which go with the ball screw shafts
- › The bearing journal configurations of the screw shaft are provided on the following pages

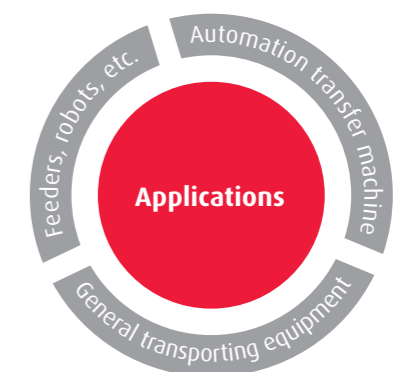

Ball Screws – Interchangeable

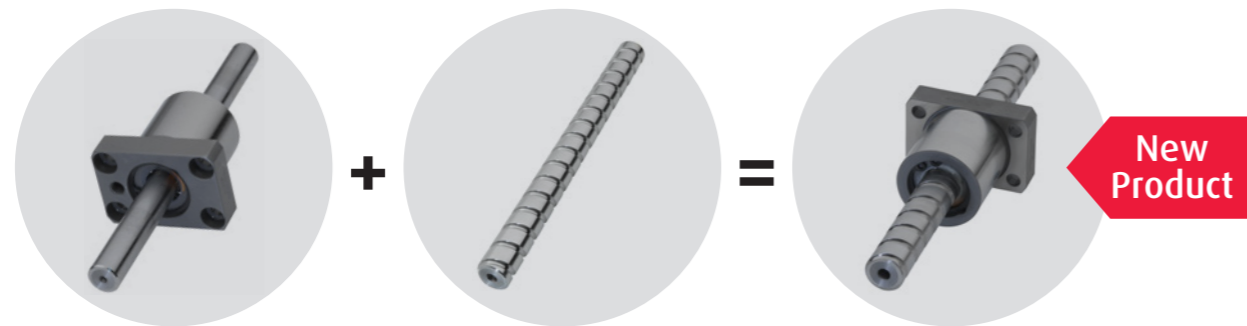

Ball nut dimensions

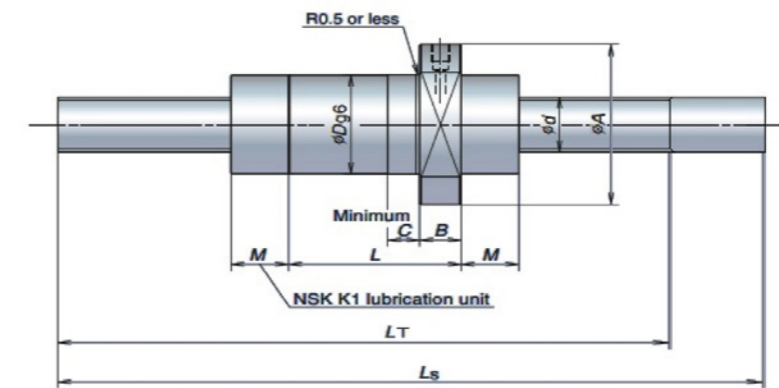
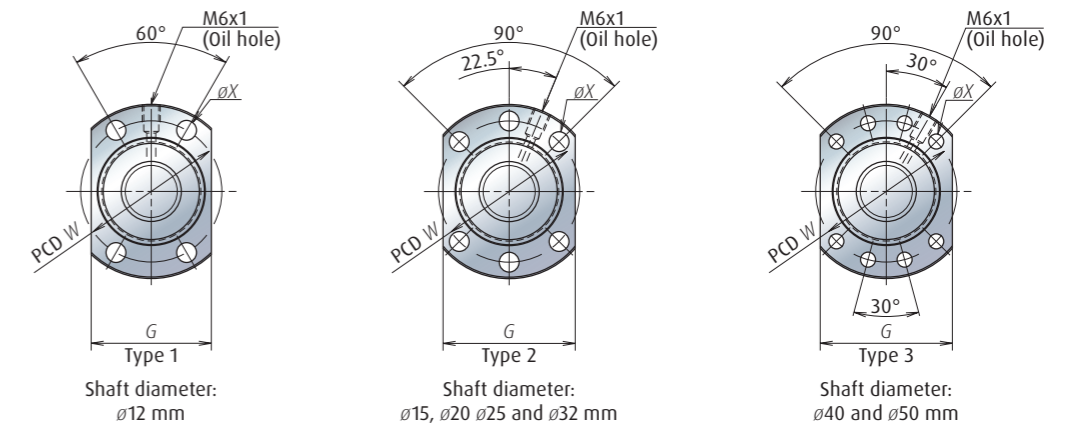

Specification number

Model No.	Shaft OD [mm]	Lead [mm]	Ca [N]	Coa [N]	D [mm]	A [mm]	G [mm]	B [mm]	L [mm]	Type No.	W [mm]	X [mm]	M [mm]	Short Version		Long Version	
														Thread length LT	Total length LS	Thread length LT	Total length LS
FCN1205	12	5	3.750	5.810	24	40	26	11	30	1	32	4,5	(18)	617	800	-	-
FCN1210	12	10	3.750	5.780	24	40	26	11	43	1	32	4,5	(18)	617	800	-	-
FCN1505	15	5	6.410	10.100	28	48	40	11	30	2	38	5,5	(18)	1303	1486	1760	1900
FCN1510	15	10	6.530	10.200	28	48	40	11	43	2	38	5,5	(18)	1303	1486	1760	1900
FCN1520	15	20	5.660	8.700	32	48	40	11	51	2	42	5,5	(18)	1293	1476	1760	1900
FCN2005	20	5	10.400	18.500	36	58	44	13	31	2	47	6,6	(18)	1303	1486	1760	1900
FCN2010	20	10	10.200	18.600	36	58	44	13	45	2	47	6,6	(18)	1303	1486	1760	1900
FCN2020	20	20	6.790	11.800	36	58	44	13	54	2	47	6,6	(18)	1293	1476	1760	1900
FCN2505	25	5	18.500	40.900	36	62	48	12	37	2	51	6,6	(21)	1303	1486	1760	1900
FCN2510	25	10	15.000	32.400	40	62	48	12	56	2	51	6,6	(21)	1303	1486	1760	1900
FCN2520	25	20	7.650	14.800	40	62	48	12	54	2	51	6,6	(21)	1293	1476	1760	1900
FCN2525	25	25	7.490	14.600	40	62	48	12	63	2	51	6,6	(21)	1288	1471	1760	1900
FCN3205	32	5	23.800	60.900	50	80	62	12	66	2	65	9	(21)	1303	1486	1760	1900
FCN3210	32	10	23.000	51.300	50	80	62	12	59	2	65	9	(21)	1303	1486	1760	1900
FCN3220	32	20	22.600	51.100	50	80	62	12	98	2	65	9	(21)	1293	1476	1760	1900
FCN4010	40	10	39.800	90.700	63	93	70	14	60	3	78	9	(21)	1303	1486	1760	1900

Please use the following designations for your order

Reference No.:

F C S 40 10 A S N J A 1 4

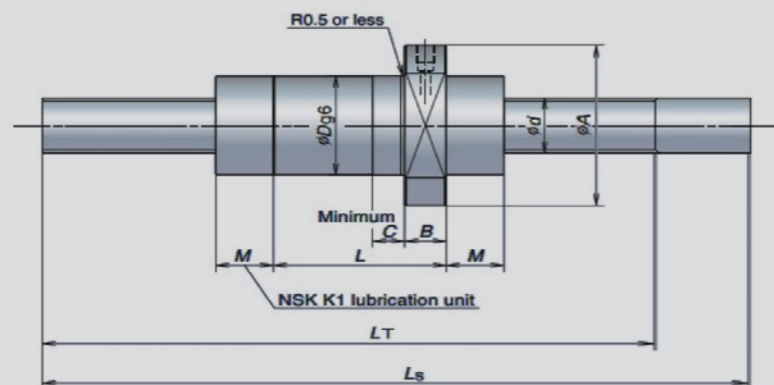
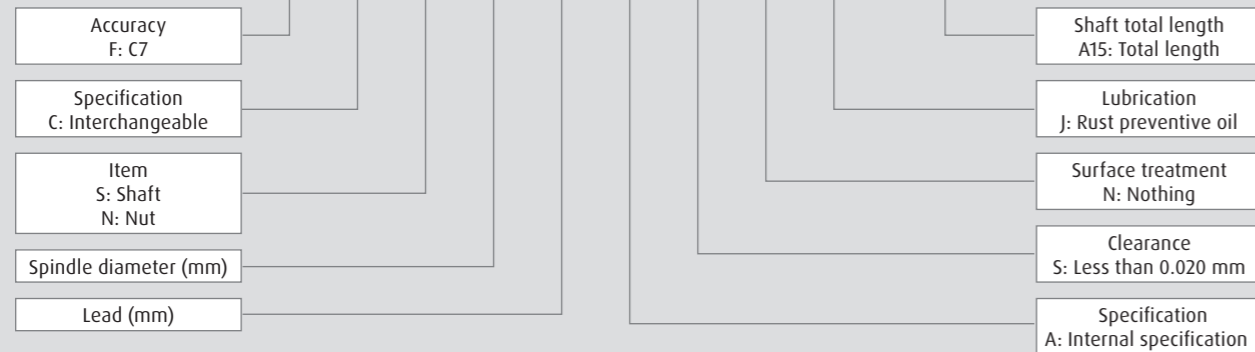

Recommended screw shaft end configuration

Basic 1

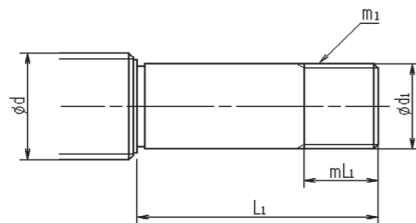

Screw shaft d	Lead l	BSBD					
		Bearing journal		Lock nut thread		Width	
		d1 g6	L1	m1	mL1	BSN/BSF	BSN/BSF-DT
12	all	8	32	M8x1	9	-	-
15	all	12	33	M12x1	10	-	-
20	all	15	38	M15x1	15	25	50
25	all	20	43	M20x1	16	28	56
32	all	25	53	M25x1.5	20	28	56
40	5.40	30 HEAVY	87	M30x1.5	26	28	56
40	10.20	30	91	M30x1.5	30	38	76
50	10	40	108	M40x1.5	30	34	68
50	20	40	108	M40x1.5	30	46	92
50	50	40	108	M40x1.5	30	46	92

Basic 2

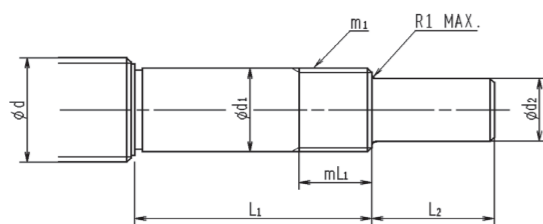

Screw shaft d	Lead l	BSBD							
		Bearing journal		Lock nut thread		Width		Drive section	
		d1 g6	L1	m1	mL1	BSN/BSF	BSN/BSF-DT	d2 h7	L2
12	all	8	32	M8x1	9	-	-	6	10
15	all	12	33	M12x1	10	-	-	10	15
20	all	15	38	M15x1	15	25	50	12	20
25	all	20	43	M20x1	16	28	56	15	27
32	all	25	53	M25x1.5	20	28	56	20	33
40	5.40	30 HEAVY	87	M30x1.5	26	28	56	25	61
40	10.20	30	91	M30x1.5	30	38	76	25	61
50	10	40	108	M40x1.5	30	34	68	35	78
50	20	40	108	M40x1.5	30	46	92	35	78
50	50	40	108	M40x1.5	30	46	92	35	78

Basic 3

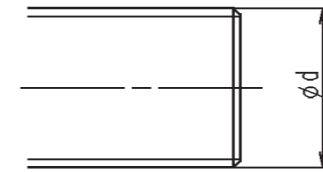

SCREW SHAFT d
12
15
20
25
32
40
50

Basic 4

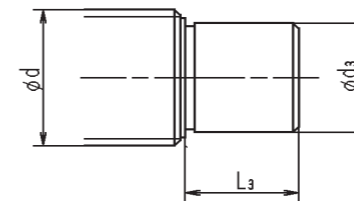

SCREW SHAFT d	SUPPORT UNIT WBK
12	WBK08S-01
15	WBK12S-01
20	WBK15S-01
25	WBK20S-01
32	WBK25S-01
40	6206
50	6207

Basic 5

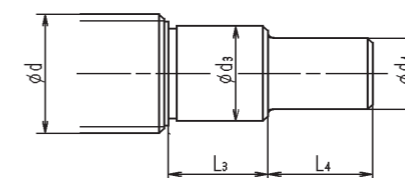

SCREW SHAFT d	SUPPORT UNIT WBK
12	WBK08S-01
15	WBK12S-01
20	WBK15S-01
25	WBK20S-01
32	WBK25S-01
40	6206
50	6207

Recommended screw shaft end configuration

Option 1

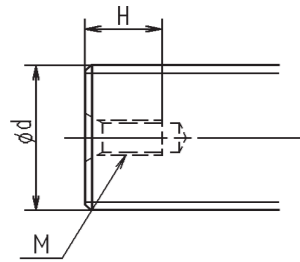

d	M	H
12	M3x0.5	9
15	M4x0.7	10
20	M6x1.0	12
25	M6x1.0	12
32	M6x1.0	12
40	M8x1.25	16
50	M8x1.25	16

Option 4

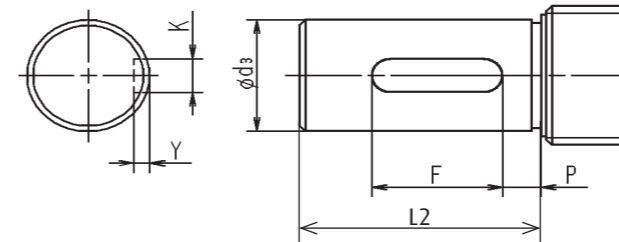

Screw shaft	Key seat				d3 g6	Drive Section	
	d	K N9	P	Y (0/+0.1)		F	d2 h7
12	2	3	1.2	14	8	6	10
15	4	3	2.5	20	12	10	15
20	5	3	3	25	15	12	20
25	6	4	3.5	30	20	15	27
32	8	4	4	40	25	20	33
40	8	5	4	40	30	25	61
50	10	5	5	50	35	30	63

Option 2

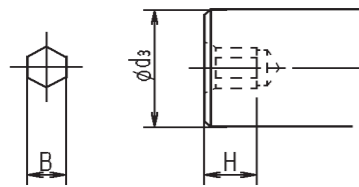

Screw shaft	Hexagonal hole	H	d3 g6
d	B (0/+0.2)		
12	-	-	6
15	4	6	10
20	5	7	15
25	6	8	20
32	8	10	25
40	10	12	30
50	12	14	35

Option 5

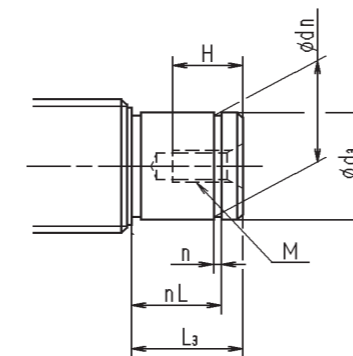

Screw shaft	Snap ring groove			Tap hole		
	d	n	dn	nL	M	H
12	0.8 (0/+0.1)	5.7 (0/-0.06)	6.8	M3x0.5	9	9
15	1.15 (0/+0.14)	9.6 (0/-0.09)	9.15	M4x0.7	10	12
20	1.15 (0/+0.14)	14.3 (0/-0.11)	10.15	M6x1.0	12	13
25	1.35 (0/+0.14)	19 (0/-0.21)	15.35	M6x1.0	12	19
32	1.35 (0/+0.14)	23.9 (0/-0.21)	16.35	M6x1.0	12	20
40	1.75 (0/+0.14)	28.6 (0/-0.21)	17.75	M8x1.25	16	22
50	1.75 (0/+0.14)	33 (0/-0.21)	18.75	M8x1.25	16	25

Option 3

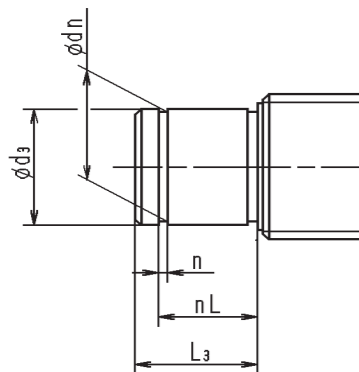

Screw shaft	Snap ring groove			Bearing journal	
	d	n	dn	d3 g6	L3
12	0.8 (0/+0.1)	5.7 (0/-0.06)	6.8	6	9
15	1.15 (0/+0.14)	9.6 (0/-0.09)	9.15	10	12
20	1.15 (0/+0.14)	14.3 (0/-0.11)	10.15	15	13
25	1.35 (0/+0.14)	19 (0/-0.21)	15.35	20	19
32	1.35 (0/+0.14)	23.9 (0/-0.21)	16.35	25	20
40	1.75 (0/+0.14)	28.6 (0/-0.21)	17.75	30	22
50	1.75 (0/+0.14)	33 (0/-0.21)	18.75	35	25

Option 6

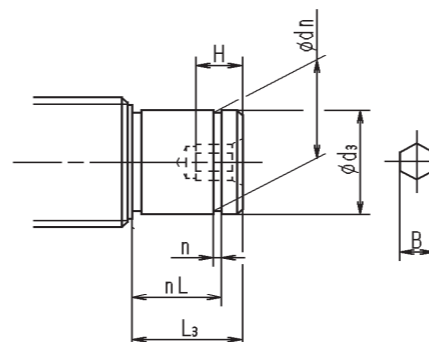

Screw shaft	Snap ring groove			Hexagonal hole		
	d	n	dn	nL	B (0/+0.2)	H
12	0.8 (0/+0.1)	5.7 (0/-0.06)	6.8	-	-	9
15	1.15 (0/+0.14)	9.6 (0/-0.09)	9.15	4	6	12
20	1.15 (0/+0.14)	14.3 (0/-0.11)	10.15	5	7	13
25	1.35 (0/+0.14)	19 (0/-0.21)	15.35	6	8	19
32	1.35 (0/+0.14)	23.9 (0/-0.21)	16.35	8	10	20
40	1.75 (0/+0.14)	28.6 (0/-0.21)	17.75	10	12	22
50	1.75 (0/+0.14)	33 (0/-0.21)	18.75	12	14	25

Recommended screw shaft end configuration

Option 7

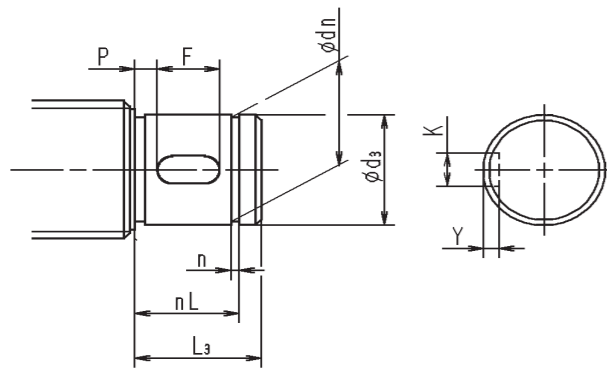

Screw shaft	Snap ring groove			Key seat			Bearing journal	
	d	n	dn	nL	K N9	P	F	d3 g6
12	0.8 (0/+0.1)	5.7 (0/-0.06)	6.8	2	3	14	6	9
15	1.15 (0/+0.14)	9.6 (0/-0.09)	9.15	4	3	20	10	12
20	1.15 (0/+0.14)	14.3 (0/-0.11)	10.15	5	3	25	15	13
25	1.35 (0/+0.14)	19 (0/-0.21)	15.35	6	4	30	20	19
32	1.35 (0/+0.14)	23.9 (0/-0.21)	16.35	8	4	40	25	20
40	1.75 (0/+0.14)	28.6 (0/-0.21)	17.75	8	5	40	30	22
50	1.75 (0/+0.14)	33 (0/-0.21)	18.75	10	5	50	35	25

Option 8

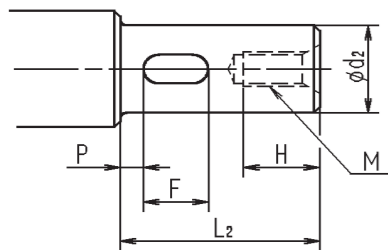

Screw shaft	Tap hole		Key seat			Drive section		
	d	M	H	K N9	P	F	Y (0/+0.1)	d2 h7
12	M3x0.5	9	2	3	-	1.2	6	10
15	M4x0.7	10	4	3	-	2.5	10	15
20	M6x1.0	12	5	3	7	3	12	20
25	M6x1.0	12	6	4	10	3.5	15	27
32	M6x1.0	12	8	4	15	4	20	33
40	M8x1.25	16	8	5	40	4	25	61
50	M8x1.25	16	10	5	40	5	30	63

Option 9

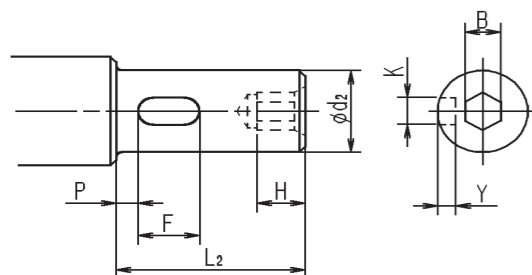

Screw shaft	Hexagonal hole		Key seat			Drive section		
	d	B (0/+0.2)	H	K N9	P	F	Y (0/+0.1)	d2 h7
12	-	-	2	3	1.2	-	6	10
15	4	6	4	3	2.5	-	10	15
20	5	7	5	3	3	7	12	20
25	6	8	6	4	3.5	10	15	27
32	8	10	8	4	4	15	20	33
40	10	12	8	5	4	40	25	61
50	12	14	10	5	5	40	30	63

Screw shaft end configuration service

It is possible to have customised modifications of our ball screws implemented quickly and reliably by our service.

The following services can be provided as an alternative:

- › Modification of ball screws based on a desired configuration
- › End machining
- › Change in preload
- › Fitting of various wipers and lubrication systems
- › Fit holes
- › Tap holes
- › Coatings
- › Special packing
- › Customised production
- › Production even in the smallest lot sizes of 1-50 units
- › Individual and special production

Please request these optional services from NSK separately.



NSK Sales Offices – Europe, Middle East and Africa

UK

NSK UK Ltd.
Northern Road, Newark
Nottinghamshire NG24 2JF
Tel. +44 (0) 1636 605123
Fax +44 (0) 1636 643276
info-uk@nsk.com

France & Benelux

NSK France S.A.S.
Quartier de l'Europe
2, rue Georges Guynemer
78283 Guyancourt Cedex
Tel. +33 (0) 1 30573939
Fax +33 (0) 1 30570001
info-fr@nsk.com

Germany, Austria, Switzerland, Nordic

NSK Deutschland GmbH
Harkortstraße 15
40880 Ratingen
Tel. +49 (0) 2102 4810
Fax +49 (0) 2102 4812290
info-de@nsk.com

Italy

NSK Italia S.p.A.
Via Garibaldi, 215
20024 Garbagnate
Milanese (MI)
Tel. +39 02 995 191
Fax +39 02 990 25 778
info-it@nsk.com

Middle East

NSK Bearings Gulf Trading Co.
JAFZA View 19, Floor 24 Office 2/3
Jebel Ali Downtown,
PO Box 262163
Dubai, UAE
Tel. +971 (0) 4 804 8205
Fax +971 (0) 4 884 7227
info-me@nsk.com

Poland & CEE

NSK Polska Sp. z o.o.
Warsaw Branch
Ul. Migdałowa 4/73
02-796 Warszawa
Tel. +48 22 645 15 25
Fax +48 22 645 15 29
info-pl@nsk.com

Russia

NSK Polska Sp. z o.o.
Russian Branch
Office I 703, Bldg 29,
18th Line of Vasilievskiy Ostrov,
Saint-Petersburg, 199178
Tel. +7 812 3325071
Fax +7 812 3325072
info-ru@nsk.com

South Africa

NSK South Africa (Pty) Ltd.
25 Galaxy Avenue
Linbro Business Park
Sandton 2146
Tel. +27 (011) 458 3600
Fax +27 (011) 458 3608
nsk-sa@nsk.com

Spain

NSK Spain, S.A.
C/ Tarragona, 161 Cuerdo Bajo
2ª Planta, 08014 Barcelona
Tel. +34 93 2892763
Fax +34 93 4335776
info-es@nsk.com

Turkey

NSK Rulmanları Orta Doğu Tic. Ltd. Şti.
Cevizli Mah. D-100 Güney Yan Yol
Kuriş Kule İş Merkezi No:2 Kat:4
34846 Cevizli - Kartal - Istanbul
Tel. +90 216 4777111
Fax +90 216 4777174
turkey@nsk.com

Please also visit our website: www.nskeurope.com

Global NSK: www.nsk.com

