

THIS DRAWING IS UNPUBLISHED. RELEASED FOR PUBLICATION
 © COPYRIGHT - BY - ALL RIGHTS RESERVED.

REVISIONS				
P	LTR	DESCRIPTION	DATE	APVD
H5		REVISED PER ECO-16-011163	08SEP2016	DD AH
H6		REVISED PER ECO-17-014752	10OCT2017	JMS AH

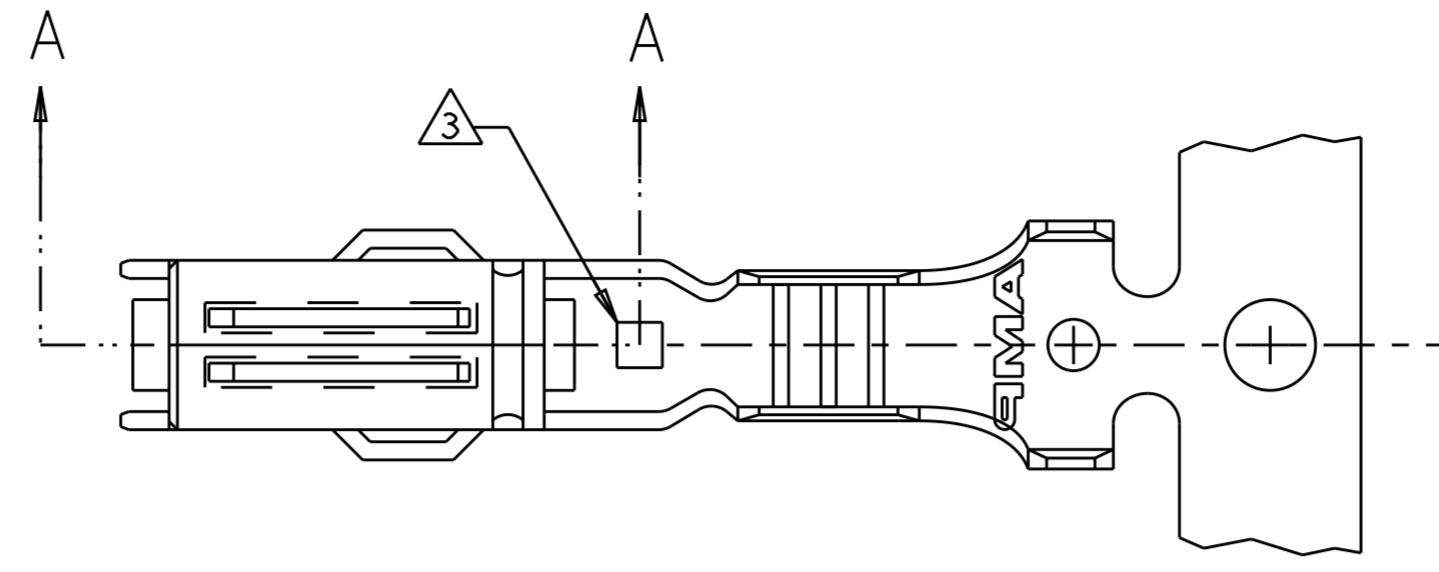
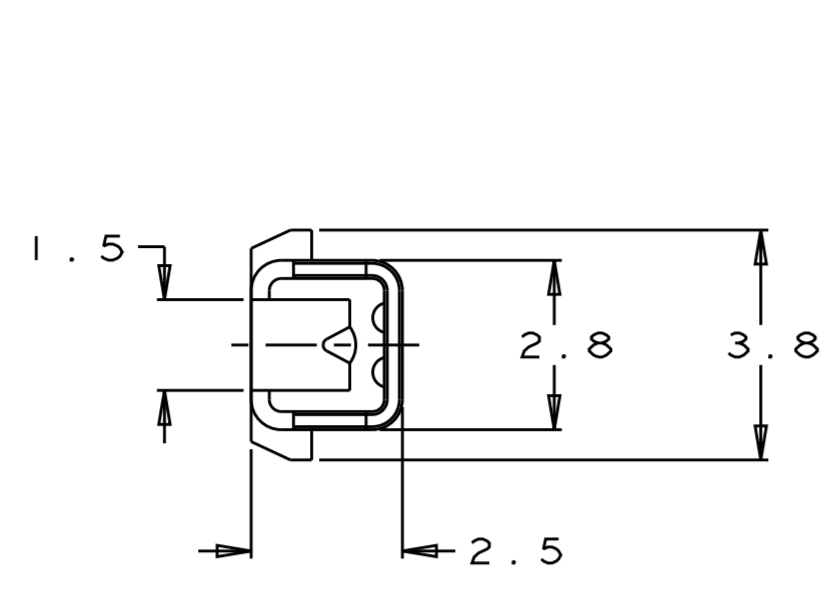

- ① 0.00076 MINIMUM THICK GOLD PLATE OVER 0.0013 MINIMUM NICKEL PLATE.
- ② 0.0008 MINIMUM THICK PRE-TIN.
- ③ 0.75 x 0.75 DIE IDENTIFICATION MARK.

GOLD PLATING IDENTIFIED IS ON TOP SPRING

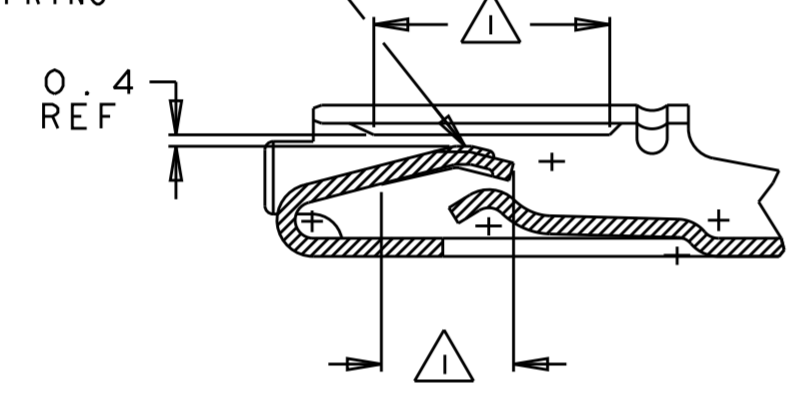

SECTION A-A

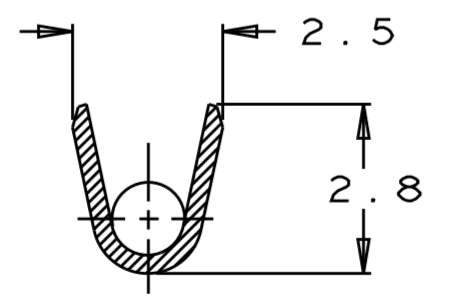
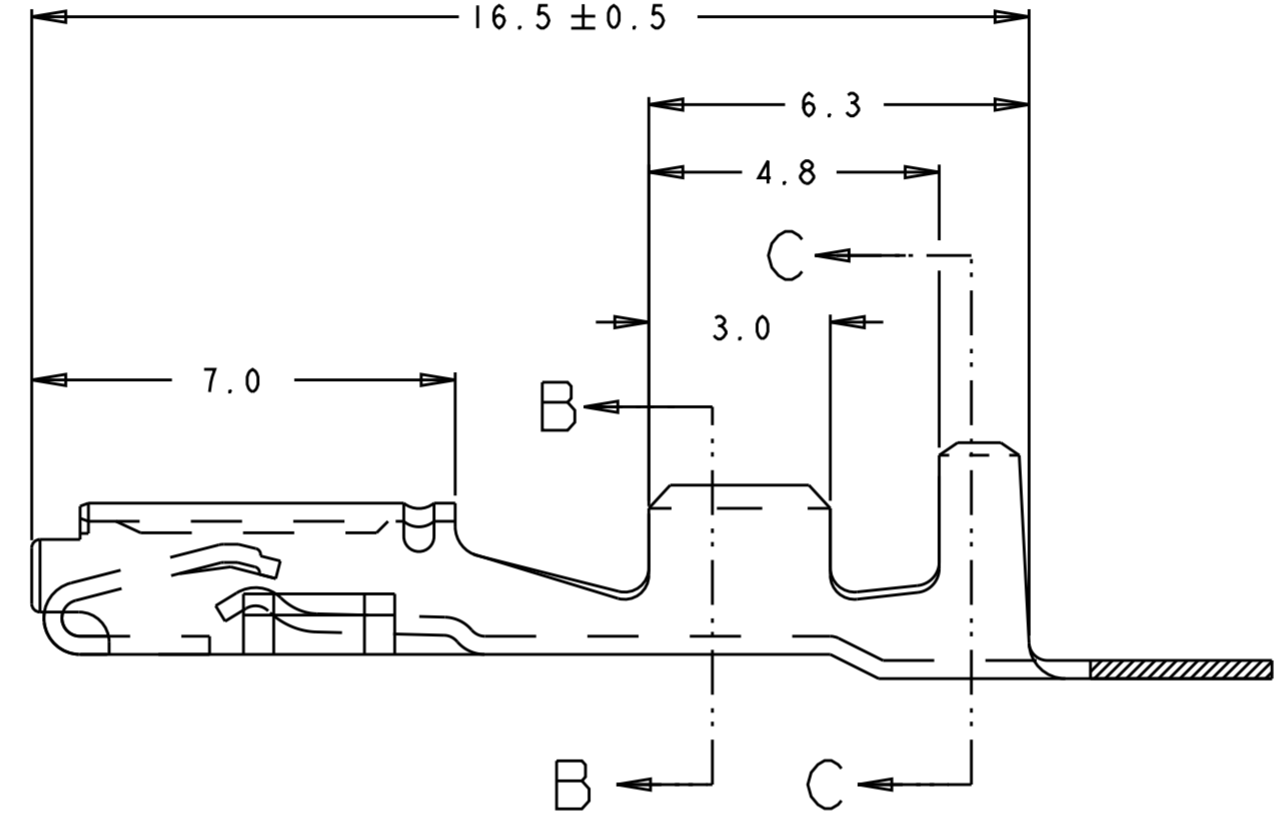

SECTION B-B

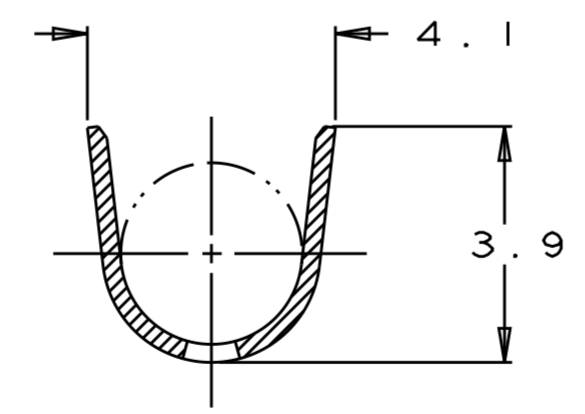

SECTION C-C

②	1.2-2.1 (SINGLE WIRE SEALING)	AVS 0.3 - 1.00mm ²	184095-2
①	1.2-2.1 (SINGLE WIRE SEALING)	AVS 0.3 - 1.00mm ²	184095-1
FINISH	INSULATION DIA	WIRE RANGE	PART NUMBER

THIS DRAWING IS A CONTROLLED DOCUMENT.

DIMENSIONS: mm	TOLERANCES UNLESS OTHERWISE SPECIFIED:	DWN KD LYLE 9/20/94	TE Connectivity NAME CONTACT, RECEPTACLE, .070 TYPE (SCAT VERSION)
0 PLC ±	1 PLC ±0.3	CHK JP KUNKLE 9/23/94	
2 PLC ±0.3	3 PLC ±	APVD JP KUNKLE 10/21/94	
4 PLC ±	ANGLES ±	PRODUCT SPEC	SIZE CAGE CODE DRAWING NO RESTRICTED TO
MATERIAL PHOS BRZ (0.3 THK)	FINISH -	APPLICATION SPEC	A200779C-184095
		WEIGHT -	SCALE 10:1 SHEET 1 OF 1 REV H6
		CUSTOMER DRAWING	