

Model 637

Very Low Jitter LVPECL or LVDS Clock

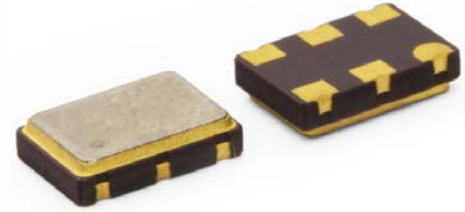

Part Dimensions:
7.0 × 5.0 × 2.0mm • 178.462mg

Features

- Ceramic Surface Mount Package
- Very Low Phase Jitter Performance, 500fs Maximum
- Fundamental or 3rd Overtone Crystal Design
- Frequency Range 10 – 320MHz *
- +2.5V or +3.3V Operation [+1.8V LVDS only]
- Output Enable Standard
- Tape and Reel Packaging, EIA-418

Applications

- SerDes
- Storage Area Networking
- Broadband Access
- SONET/SDH/DWDM
- PON
- Ethernet/GbE/SyncE
- Fiber Channel
- Test and Measurement

Standard Frequencies		
- 25.00MHz	- 125.00MHz	- 187.50MHz
- 50.00MHz	- 150.00MHz	- 200.00MHz
- 74.1758MHz	- 155.52MHz	- 212.50MHz
- 74.25MHz	- 156.25MHz	- 250.00MHz
- 100.00MHz	- 161.1328MHz	- 312.50MHz

* See Page 9 for additional developed frequencies.
Check with factory for availability of frequencies not listed.

Description

CTS Model 637 is a low cost, high performance clock oscillator supporting differential LVPECL or LVDS outputs. Employing the latest IC technology, M637 has excellent stability and low jitter/phase noise performance.

Ordering Information

Model	Output Type	Frequency Code [MHz]	Frequency Stability	Temperature Range	Supply Voltage	Packaging
637	P	XXX or XXXX	3	I	3	T

Code	Output
P	LVPECL - Pin 1 Enable
L	LVDS - Pin 1 Enable
E	LVPECL - Pin 2 Enable
V	LVDS - Pin 2 Enable

Code	Stability
6	±20ppm ²
5	±25ppm
4	±30ppm
3	±50ppm
2	±100ppm

Code	Temp. Range
A	-10°C to +60°C
C	-20°C to +70°C
I	-40°C to +85°C
G	-40°C to +105°C ³

Code	Voltage
M	+1.8Vdc ⁴
2	+2.5Vdc
3	+3.3Vdc

Code	Frequency
Product Frequency Code ¹	

Code	Packing
T	1k pcs./reel

Notes:

- 1] Refer to document 016-1454-0, Frequency Code Tables. 3-digits for frequencies <100MHz, 4-digits for frequencies 100MHz or greater.
- 2] Check factory for availability. Temperature codes A and C only.
- 3] Check factory for availability. Stability codes 2 and 3 only.
- 4] LVDS output only. Consult factory for availability.

**Not all performance combinations and frequencies may be available.
Contact your local CTS Representative or CTS Customer Service for availability.**

This product is specified for use only in standard commercial applications. Supplier disclaims all express and implied warranties and liability in connection with any use of this product in any non-commercial applications or in any application that may expose the product to conditions that are outside of the tolerances provided in its specification.



Electrical Specifications

Operating Conditions

PARAMETER	SYMBOL	CONDITIONS	MIN	TYP	MAX	UNIT
Maximum Supply Voltage	V_{CC}	-	-0.5	-	5.0	V
Supply Voltage [Note 1]	V_{CC}	$\pm 5\%$	1.710	1.8	1.890	V
			3.135	3.3	3.465	
Supply Current						
LVPECL	I_{CC}	$V_{CC} = +2.5V$ or $+3.3V$ @ Maximum Load	-	55	88	mA
LVDS			-	45	66	
LVDS			$V_{CC} = +1.8$ @ Maximum Load	-	7	
Operating Temperature	T_A	-	-20		+70	°C
			-40	+25	+85	
			-40		+105	
Storage Temperature	T_{STG}	-	-50	-	+125	°C

Frequency Stability

PARAMETER	SYMBOL	CONDITIONS	MIN	TYP	MAX	UNIT
Frequency Range						
LVPECL	f_O	$V_{CC} = +2.5V$ or $+3.3V$		10 - 320		MHz
LVDS				10 - 320		
LVDS			$V_{CC} = +1.8V$	20 - 220		
Frequency Stability [Note 2]	$\Delta f/f_O$	-		20, 25, 30, 50 or 100		\pm ppm
Aging	$\Delta f/f_{25}$	First Year @ $+25^\circ C$, nominal V_{CC}	-3	-	3	ppm

1.] LVDS output only for +1.8V option.

2.] Inclusive of initial tolerance at time of shipment, changes in supply voltage, load, temperature and 1st year aging.

Output Parameters

PARAMETER	SYMBOL	CONDITIONS	MIN	TYP	MAX	UNIT
Output Type	-	-		LVPECL		-
Output Load	R_L	Terminated to $V_{CC} - 2.0V$	-	50	-	Ohms
Output Voltage Levels	V_{OH}	PECL Load, $-20^\circ C$ to $+70^\circ C$	$V_{CC} - 1.025$	-	$V_{CC} - 0.880$	V
	V_{OL}		$V_{CC} - 1.810$	-	$V_{CC} - 1.620$	
	V_{OH}	PECL Load, $-40^\circ C$ to $+85^\circ C$	$V_{CC} - 1.085$	-	$V_{CC} - 0.880$	V
	V_{OL}		$V_{CC} - 1.830$	-	$V_{CC} - 1.555$	
Output Duty Cycle	SYM	@ $V_{CC} - 1.3V$	45	-	55	%
Rise and Fall Time	T_{R}, T_F	@ 20%/80% Levels, $R_L = 50$ Ohms	-	0.3	0.7	ns
LVDS						
Output Type	-	-		LVDS		-
Output Load	R_L	Between Outputs	-	100	-	Ohms
Output Voltage Levels	V_{OH}	LVDS Load	-	1.43	1.60	V
	V_{OL}		0.90	1.10	-	
Output Duty Cycle	SYM	@ 1.25V	45	-	55	%
Differential Output Voltage	V_{OD}	$R_L = 100$ Ohms	247	330	454	mV
Offset Voltage	V_{OS}	LVDS Load	1.125	1.25	1.375	V
Rise and Fall Time	T_{R}, T_F	@ 20%/80% Levels, $R_L = 100$ Ohms	-	0.4	0.7	ns

Electrical Specifications

Output Parameters

PARAMETER	SYMBOL	CONDITIONS	MIN	TYP	MAX	UNIT
Start Up Time	T_S	Application of V_{CC}	-	2	5	ms
Enable Function [Standby]						
Enable Input Voltage	V_{IH}	Pin 1 or 2 Logic '1', Output Enabled	$0.7V_{CC}$	-	-	V
Disable Input Voltage	V_{IL}	Pin 1 or 2 Logic '0', Output Disabled	-	-	$0.3V_{CC}$	V
Disable Time	T_{PLZ}	Pin 1 or 2 Logic '0', Output Disabled	-	-	200	ns
Enable Time	T_{PLZ}	Pin 1 or 2 Logic '1', Output Enabled	-	-	2	ms
Phase Jitter, RMS	t_{jrms}	40MHz - 320MHz, Bandwidth 12kHz to 20MHz	-	300	500	fs
		10MHz - 39.999MHz, Bandwidth 12kHz to 5MHz	-	500	<1	ps

Enable Truth Table

Pin 1 or Pin 2	Pin 4 & Pin 5
Logic '1'	Output
Open	Output
Logic '0'	High Imp.

Test Circuit

LVPECL

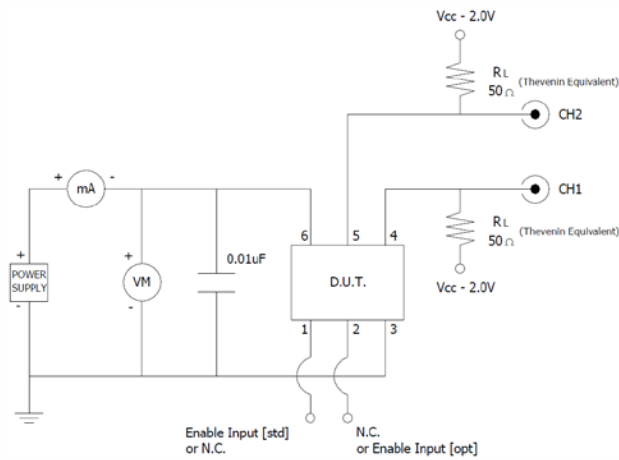

LVDS

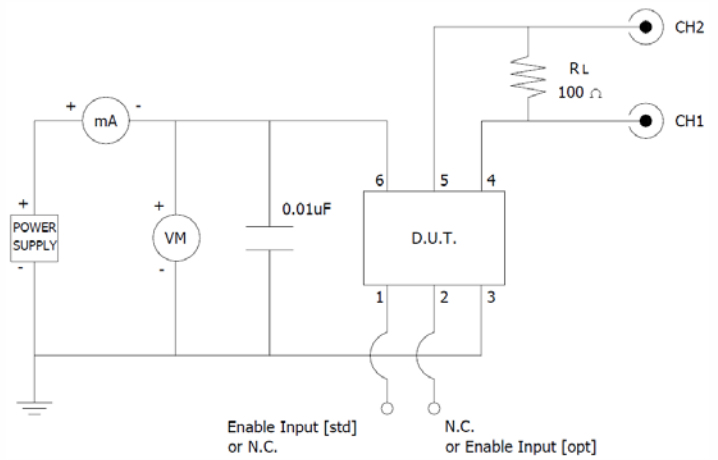

Output Waveform

LVPECL or LVDS

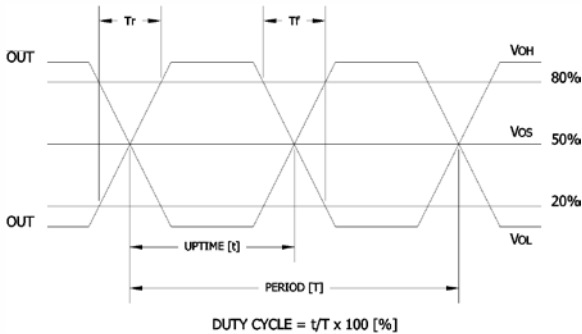

Electrical Specifications

Performance Data

Phase Noise [typical]

25MHz, LVPECL, $V_{CC} = 3.3V$, $T_A = +25^\circ C$

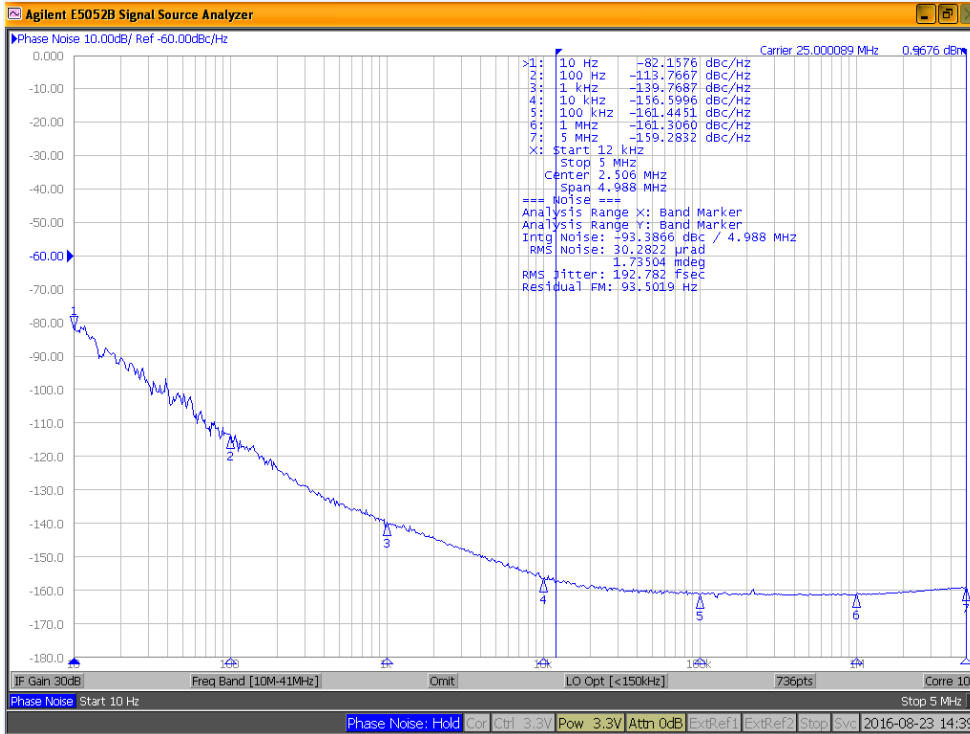

100MHz, LVPECL, $V_{CC} = 3.3V$, $T_A = +25^\circ C$

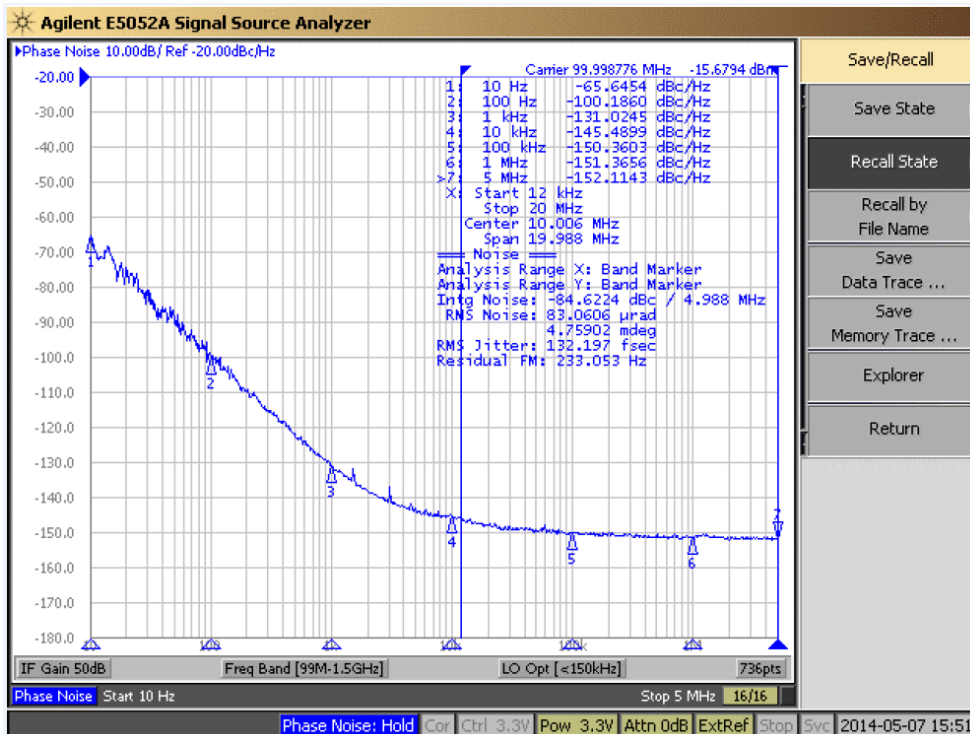

Electrical Specifications

Performance Data

Phase Noise [typical]

312.50MHz, LVPECL, $V_{CC} = 3.3V$, $T_A = +25^\circ C$

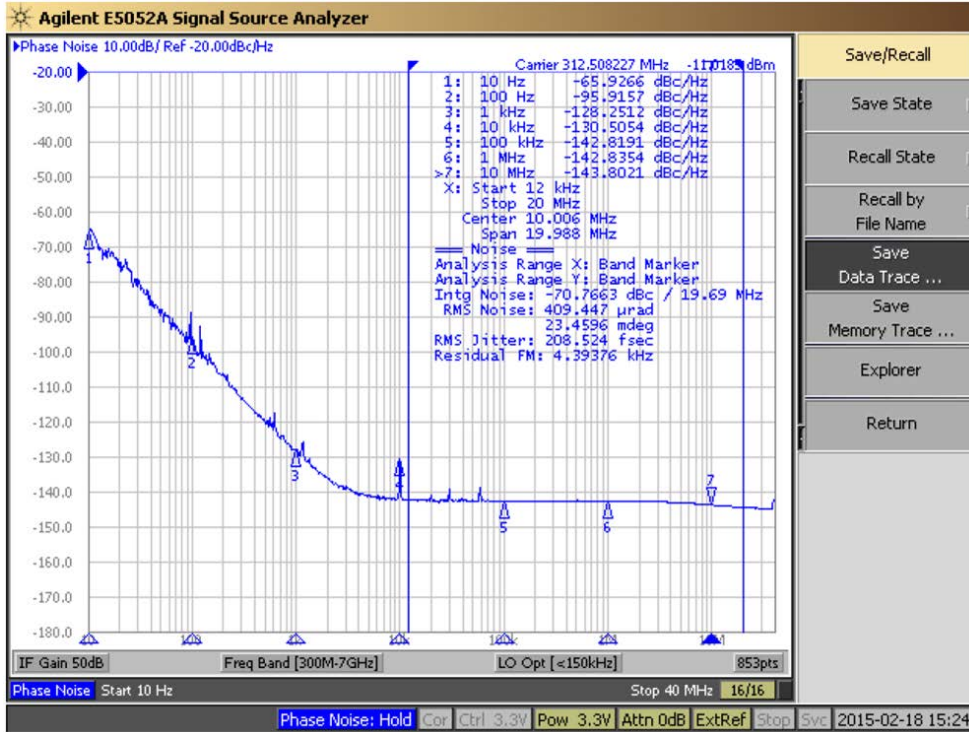

155.52MHz, LVDS, $V_{CC} = 3.3V$, $T_A = +25^\circ C$

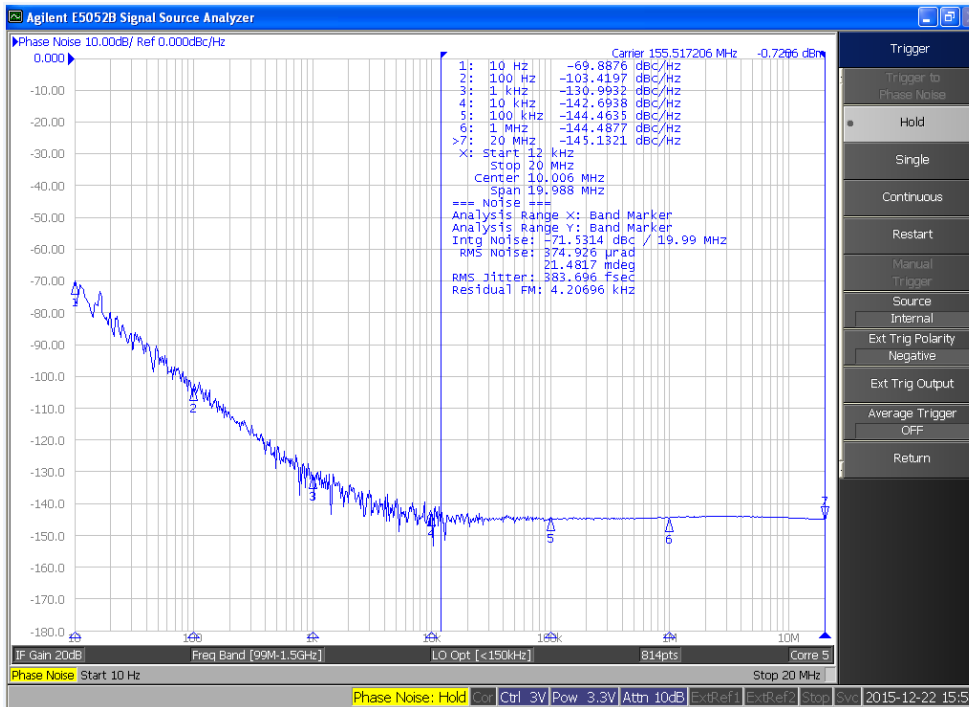



Electrical Specifications

Phase Noise Tabulated

Typical, $V_{CC} = 3.3V$, $T_A = +25^{\circ}C$

PARAMETER	SYMBOL	CONDITIONS	TYP	UNIT
LVPECL @ 25.00MHz				
Phase Noise		Single Side Band		
		@ 10Hz	-82.16	
		@ 100Hz	-113.77	
		@ 1kHz	-139.77	
	-	@ 10kHz	-156.60	dBc/Hz
		@ 100kHz	-161.45	
		@ 1MHz	-161.31	
	@ 5MHz	-159.28		
Phase Jitter, RMS	tjrms	Integration Bandwidth 12kHz - 20MHz	192.78	fs

PARAMETER	SYMBOL	CONDITIONS	TYP	UNIT
LVPECL @ 312.20MHz				
Phase Noise		Single Side Band		
		@ 10Hz	-65.93	
		@ 100Hz	-95.92	
		@ 1kHz	-128.25	
	-	@ 10kHz	-130.51	dBc/Hz
		@ 100kHz	-142.82	
		@ 1MHz	-142.84	
	@ 10MHz	-143.80		
Phase Jitter, RMS	tjrms	Integration Bandwidth 12kHz - 20MHz	208.52	fs

PARAMETER	SYMBOL	CONDITIONS	TYP	UNIT
LVPECL @ 100.00MHz				
Phase Noise		Single Side Band		
		@ 10Hz	-65.65	
		@ 100Hz	-100.19	
		@ 1kHz	-131.02	
	-	@ 10kHz	-145.49	dBc/Hz
		@ 100kHz	-150.36	
		@ 1MHz	-151.37	
	@ 5MHz	-152.11		
Phase Jitter, RMS	tjrms	Integration Bandwidth 12kHz - 20MHz	132.20	fs

PARAMETER	SYMBOL	CONDITIONS	TYP	UNIT
LVDS @ 155.52MHz				
Phase Noise		Single Side Band		
		@ 10Hz	-69.89	
		@ 100Hz	-103.42	
		@ 1kHz	-130.99	
	-	@ 10kHz	-142.69	dBc/Hz
		@ 100kHz	-144.46	
		@ 1MHz	-144.49	
	@ 20MHz	-145.13		
Phase Jitter, RMS	tjrms	Integration Bandwidth 12kHz - 20MHz	383.70	fs

Mechanical Specifications

Package Drawing

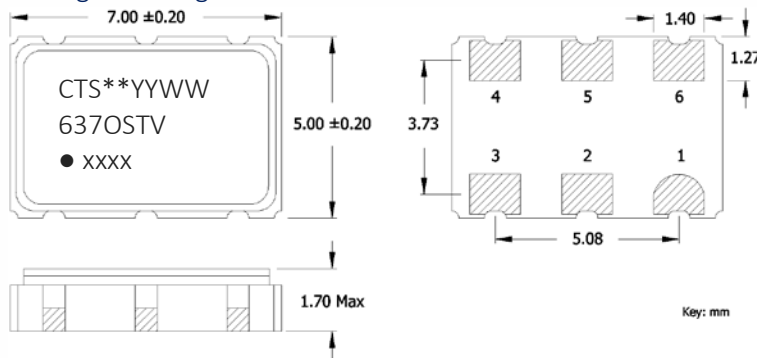

Marking Information

1. ** - Manufacturing Site Code.
2. YYWW – Date Code; YY – year, WW – week.
3. O – Output Type; P or E = LVPECL, L or V = LVDS.
4. ST – Frequency Stability/Temperature Code.
[Refer to Ordering Information]
5. V – Voltage Code; 3 = 3.3V, 2 = 2.5V.
6. xxxx – Frequency Code.
3-digits, frequencies below 100MHz
4-digits, frequencies 100MHz or greater
[See document 016-1454-0, Frequency Code Tables.]

Recommended Pad Layout

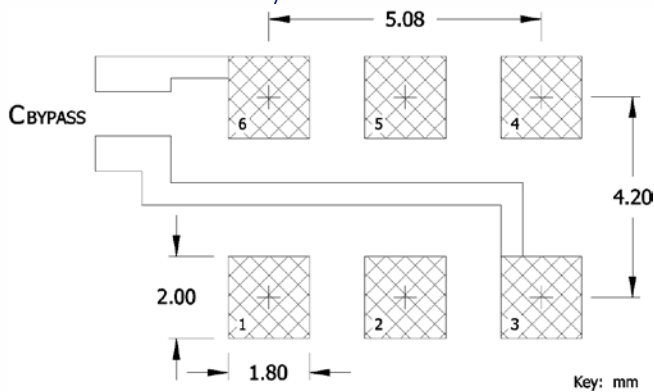

Notes

1. JEDEC termination code (e4). Barrier-plating is nickel [Ni] with gold [Au] flash plate.
2. Reflow conditions per JEDEC J-STD-020; +260°C maximum, 20 seconds.
3. MSL = 1.

Pin Assignments

Pin	Symbol	Function
1	EOH or N.C.	Enable [std] or No Connect
2	N.C. or EOH	No Connect or Enable [opt]
3	GND	Circuit & Package Ground
4	Output	RF Output
5	$\overline{\text{Output}}$	Complimentary RF Output
6	V_{CC}	Supply Voltage

Packaging - Tape and Reel

Tape Drawing

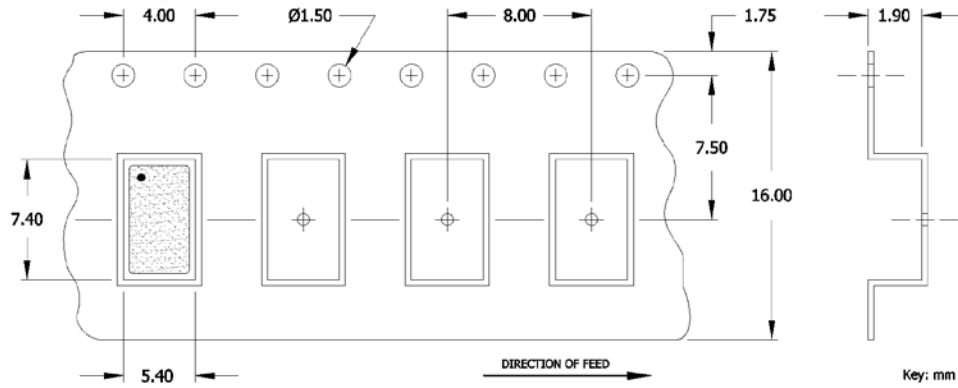

Reel Drawing

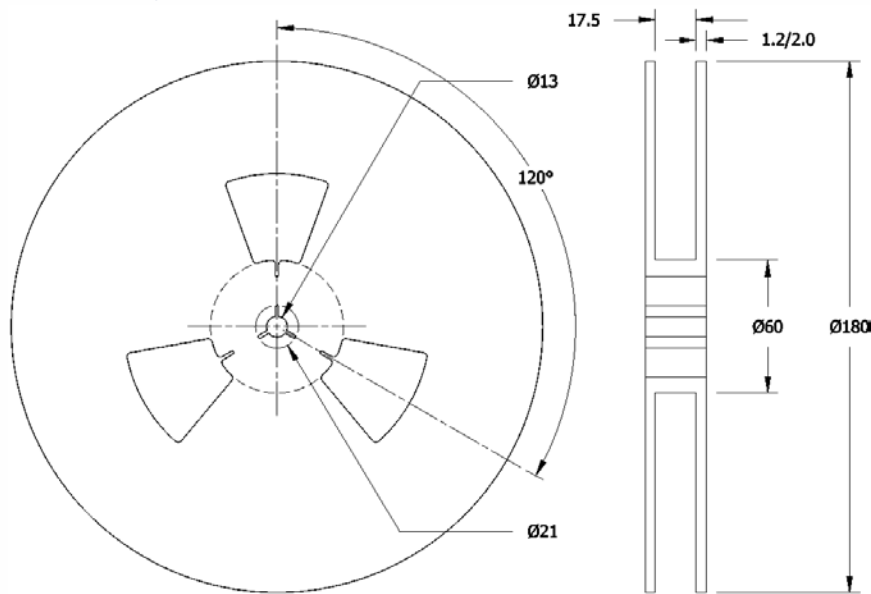

Notes

1. Device quantity is 1k pieces maximum per 180mm reel.
2. Complete CTS part number, frequency value and date code information must appear on reel and carton labels.



Addendum

Additional Developed Frequencies – MHz

FREQUENCY	FREQUENCY CODE	FREQUENCY	FREQUENCY CODE	FREQUENCY	FREQUENCY CODE	FREQUENCY	FREQUENCY CODE
10.000000	100	153.600000	1536				
19.440000	194	156.253906	156A				
27.000000	270	167.372800	167A				
40.000000	400	173.370800	1733				
44.736000	447	175.000000	1750				
80.000000	800	178.500000	1785				
120.000000	1200	180.000000	1800				
133.000000	1330	184.320000	1843				
148.351600	148A	225.000000	2250				
148.500000	1485						

Frequency Codes for Cover Page Table – MHz

FREQUENCY	FREQUENCY CODE	FREQUENCY	FREQUENCY CODE	FREQUENCY	FREQUENCY CODE	FREQUENCY	FREQUENCY CODE
25.000000	250	100.000000	1000	156.250000	1562	212.500000	2125
50.000000	500	125.000000	1250	161.132800	1611	250.000000	2500
74.175800	74A	150.000000	1500	187.500000	1875	312.500000	3125
74.250000	742	155.520000	1555	200.000000	2000		

Mouser Electronics

Authorized Distributor

Click to View Pricing, Inventory, Delivery & Lifecycle Information:

CTS:

[637P5003I2T](#) [637P7423I2T](#) [637L21253I2T](#) [637P15553I3T](#) [637P74A3I2T](#) [637L12503I2T](#) [637L2503I2T](#)
[637L12503I3T](#) [637P21253I2T](#) [637P15623I3T](#) [637L13303I3T](#) [637P21253I3T](#) [637P12503I3T](#) [637P15623I2T](#)
[637P10003I3T](#) [637L2503I3T](#) [637L21253I3T](#) [637L13303I2T](#) [637L74A3I2T](#) [637P7423I3T](#) [637L15553I3T](#)
[637L10003I2T](#) [637L7423I2T](#) [637P5003I3T](#) [637P13303I2T](#) [637P13303I3T](#) [637P15553I2T](#) [637L5003I2T](#)
[637P2503I3T](#) [637L5003I3T](#) [637L15553I2T](#) [637L15623I2T](#) [637P2503I2T](#) [637P12503I2T](#) [637L7423I3T](#)
[637L15623I3T](#) [637P10003I2T](#) [637P74A3I3T](#) [637L10003I3T](#) [637L74A3I3T](#) [637P50B5I2T](#) [637L4006C2T](#)
[637L7776A3T](#) [637V20005I2T](#) [637V15936A2T](#) [637V15552I3T](#) [637P156G3I2T](#) [637P15936C2T](#) [637V31253C3T](#)
[637E14855I2T](#) [637P4473C3T](#) [637E17853C3T](#) [637V74A5C3T](#) [637L17856C3T](#) [637L1945C3T](#) [637E14833I3T](#)
[637L15362I2T](#) [637P10626A2T](#) [637P15556C3T](#) [637E7772I3T](#) [637P14853I3T](#) [637V16252I3T](#) [637P1943C3T](#)
[637V74A5C2T](#) [637P18755C3T](#) [637L18436A3T](#) [637L14853I2T](#) [637L20006C2T](#) [637L5006A2T](#) [637E12502I2T](#)
[637L12286A3T](#) [637E156J6A3T](#) [637P4003C3T](#) [637P16253C2T](#) [637L20005C3T](#) [637L14855I3T](#) [637V28572I3T](#)
[637L167A3C3T](#) [637L15552I2T](#) [637E156J3C3T](#) [637P167A3C3T](#) [637V15556C2T](#) [637P14832I2T](#) [637E4473C2T](#)
[637L18433I2T](#) [637P2706A2T](#) [637P15625I2T](#) [637E167A3I2T](#) [637E7426A2T](#) [637V20003C2T](#) [637P12286C3T](#)
[637V13306A3T](#) [637E18756A2T](#) [637V18435I2T](#) [637L15365I2T](#) [637L11003I3T](#) [637V16255C3T](#) [637P2505I2T](#)
[637P10005C2T](#) [637V7422I2T](#)