

REVISIONS			
REV	DESCRIPTION, ECN, EAR NO.	DATE	APPD
E	PRODUCT DRAWING (EAR 14444)	MAY04/16	K.L.
F	PRODUCT DRAWING (EAR 14444)	OCT25/17	K.L.

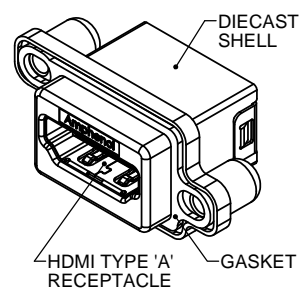
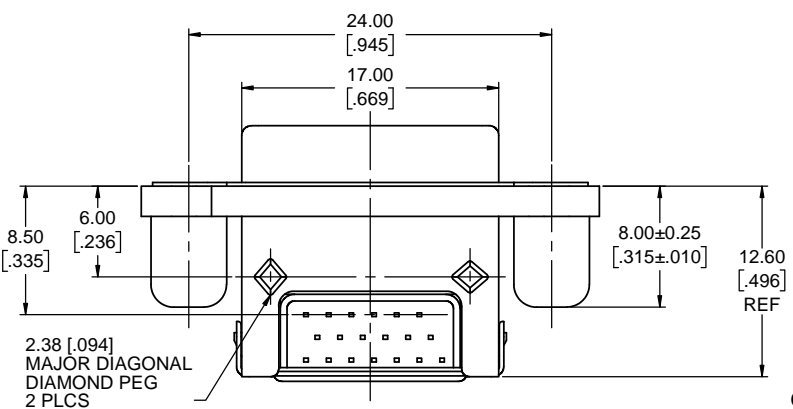
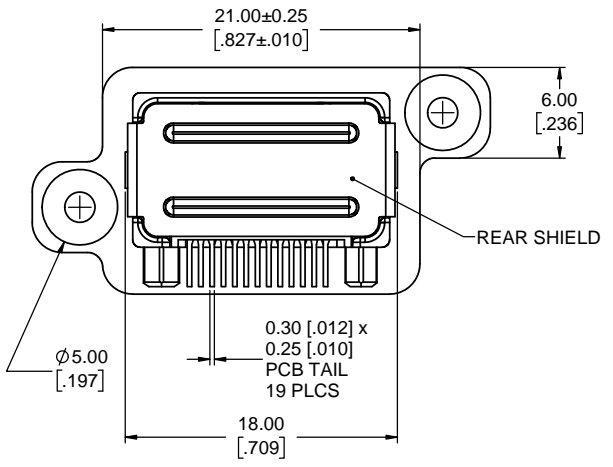
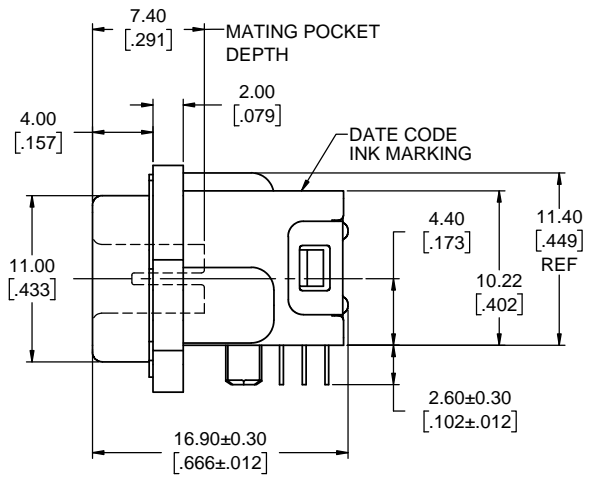
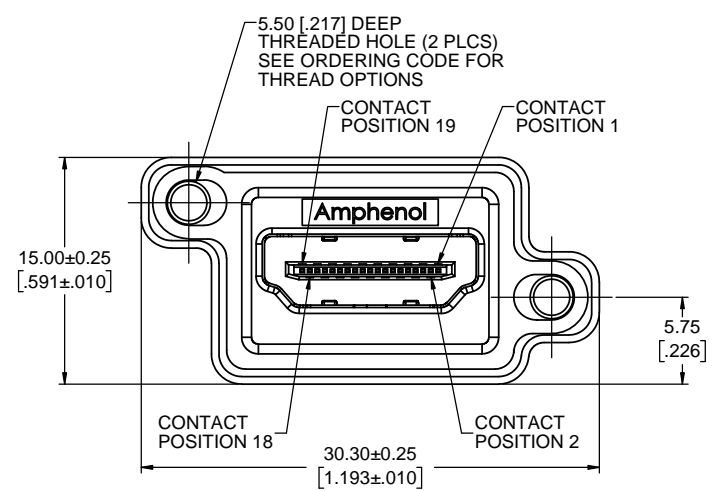

ORDERING CODE: MHDR - A111 - XX

SERIES, RUGGED HDMI

HDMI TYPE 'A' RECEPTACLE, SINGLE PORT, RIGHT ANGLE PCB TAIL

THREAD OPTION
3 = #4-40 UNC THREAD
M = M3 x 0.5 THREAD

DUST COVER OPTION
0 = NO DUST COVER SUPPLIED
1 = WITH GREY DUST COVER SUPPLIED
5 = WITH BLACK DUST COVER SUPPLIED

SPECIAL CONNECTORS
MANY UNIQUE FEATURES ARE READILY AVAILABLE TO SUIT CUSTOMER REQUIREMENTS. CONSULT WITH AMPHENOL CANADA FOR DETAILS.

NOTES:

- MATERIAL:**
 - ALL MATERIALS ARE RoHS COMPLIANT PER EU DIRECTIVE 2011/65/EU AND AMENDMENTS
 - OUTER SHELL - DIECAST ZINC ALLOY, MATTE TIN OVER NICKEL PLATED
 - CONTACTS - COPPER ALLOY, PLATED WITH 0.76µm (30µ") GOLD OVER 1.27µm (50µ") MINIMUM NICKEL ON THE MATING AREA WITH MATTE TIN OVER NICKEL ON THE TAILS.
 - HDMI HOUSING - ENGINEERING THERMOPLASTIC, HIGH TEMPERATURE RESISTANT, FLAMMABILITY RATING UL94V-0, BLACK
 - HDMI SHIELD & BACK COVER - STAINLESS STEEL, PASSIVATED
 - GASKET - CONDUCTIVE SILICONE RUBBER, BLACK
 - DUST COVER - SILICONE RUBBER WITH NICKEL PLATED BRASS BUSHING. SEE ORDERING CODE FOR COLOUR OPTION
- ENVIRONMENTAL PERFORMANCE PER IEC 60529 CODE IP67 FOR SEAL BETWEEN MATING AREA AND PCB SIDE OF CONNECTOR. GASKET PROVIDES SEAL TO INSIDE FACE OF ENCLOSURE PANEL.
- CURRENT & VOLTAGE RATING: 0.5 AMPERES, 40 VAC RMS.
- CONTACT RESISTANCE: 10 MILLIOHMS MAXIMUM, INITIAL.
- OPERATING TEMPERATURE: -55°C TO +105°C.
- DUST COVERS MAY BE ORDERED SEPARATELY. SPECIFY
 - PART NUMBER MHDR-2A11-004BP FOR GREY COVER OR
 - PART NUMBER MHDR-2A11-014BP FOR BLACK COVER

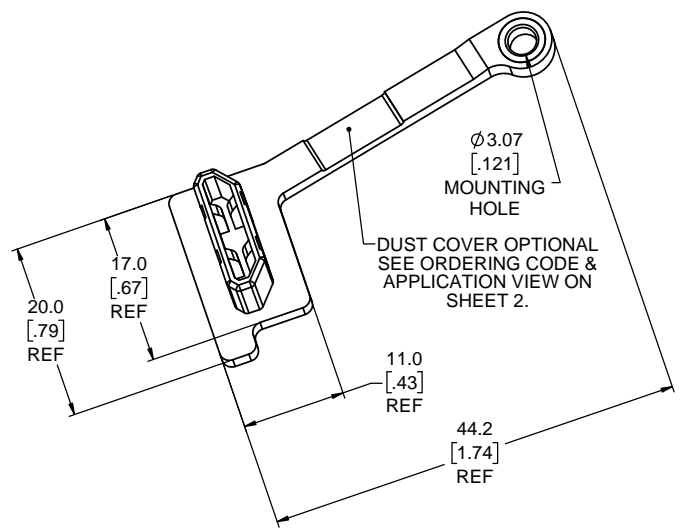

THIS DOCUMENT CONTAINS PROPRIETARY INFORMATION AND SUCH INFORMATION MAY NOT BE DISCLOSED TO OTHERS FOR ANY PURPOSE OR USED FOR MANUFACTURING PURPOSES WITHOUT WRITTEN PERMISSION FROM AMPHENOL CANADA CORP.

UNLESS SPECIFIED OTHERWISE	DRAWN	B.COPPING	MAR28/12
PRIMARY UNITS MILLIMETERS	CHECKED		
SECONDARY INCHES	M.E. APPD		
REFERENCE IN PARENTHESES	Q.A. APPD		
GENERAL TOLERANCES	DWG APPR.	K.LAMBIE	APR2/12
1 DECIMAL PLACE	ENG. REL. NO.	EAR 14043	
2 DECIMAL PLACES ±0.15	REF.		
3 DECIMAL PLACES	THIRD ANGLE PROJECTION		
ANGULAR DEGREES	DO NOT SCALE DRAWING		

Amphenol Canada Corp.
www.amphenolcanada.com

MHDR SERIES, RUGGED HDMI TYPE A RECEPTACLE, RIGHT ANGLE, PCB TAIL, THREAD & DUST COVER OPTIONS, RoHS COMPLIANT

DWG. NO. P-MHDR-A111-XX REV F

CODE ID NO. 03554 DWG SIZE: X SCALE: 4:1 SHEET 1 OF 2



REVISIONS			
REV	DESCRIPTION, ECN, EAR NO.	DATE	APP'D
E	PRODUCT DRAWING (EAR 14444)	MAY04/16	K.L
F	PRODUCT DRAWING (EAR 14444)	OCT25/17	K.L

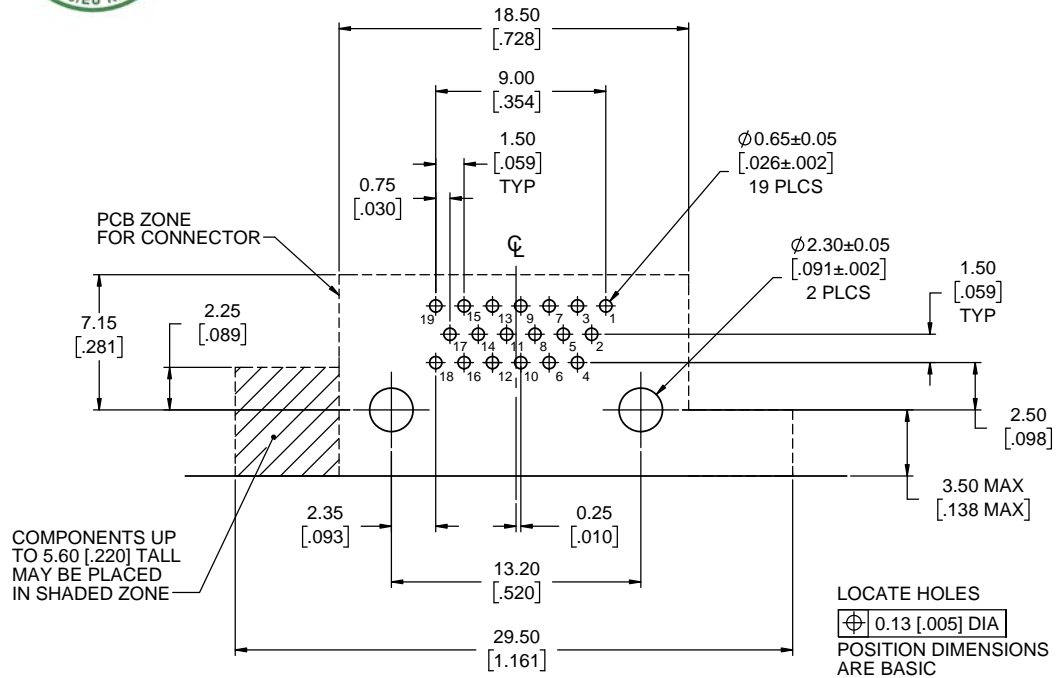

RECOMMENDED PCB LAYOUT
COMPONENT SIDE OF BOARD

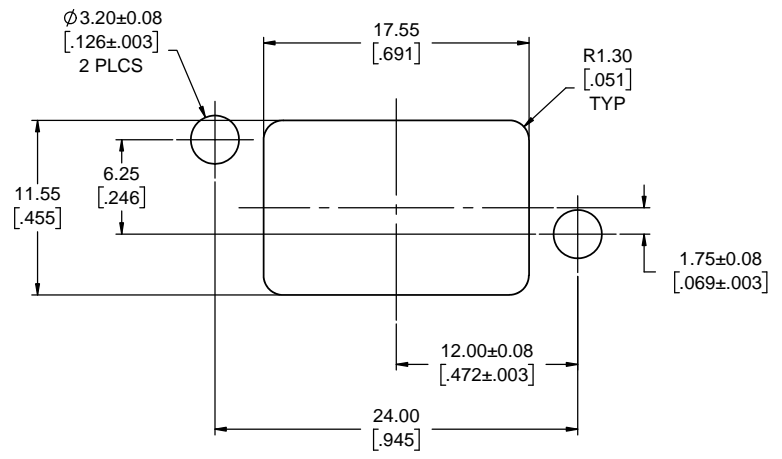

RECOMMENDED PANEL CUTOUT

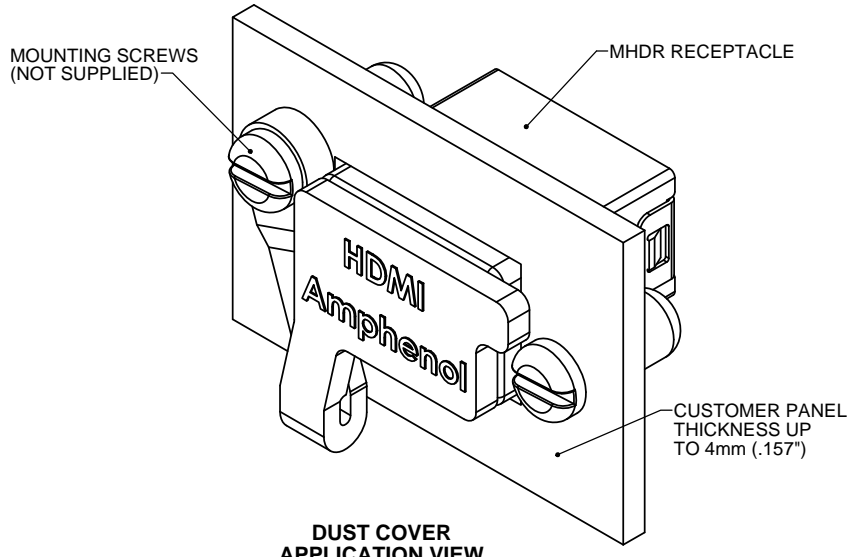

THIS DOCUMENT CONTAINS PROPRIETARY INFORMATION AND SUCH INFORMATION MAY NOT BE DISCLOSED TO OTHERS FOR ANY PURPOSE OR USED FOR MANUFACTURING PURPOSES WITHOUT WRITTEN PERMISSION FROM AMPHENOL CANADA CORP.

UNLESS SPECIFIED OTHERWISE	DRAWN	B.COPPING	MAR28/12
PRIMARY UNITS MILLIMETERS	CHECKED		
SECONDARY INCHES	M.E. APP'D		
REFERENCE IN PARENTHESES	Q.A. APP'D		
GENERAL TOLERANCES	DWG APPR.	K.LAMBIE	APR2/12
1 DECIMAL PLACE	ENG. REL. NO.	EAR 14043	
2 DECIMAL PLACES ± 0.15	REF.		
3 DECIMAL PLACES	THIRD ANGLE PROJECTION		
ANGULAR DEGREES			

Amphenol Canada Corp.
www.amphenolcanada.com
 MHDR SERIES, RUGGED HDMI TYPE A RECEPTACLE, RIGHT ANGLE, PCB TAIL, THREAD & DUST COVER OPTIONS, RoHS COMPLIANT

DWG. NO. **P-MHDR-A111-XX** REV **F**

CODE ID NO. 03554 DWG SIZE: X SCALE: 4:1 SHEET 2 OF 2

Mouser Electronics

Authorized Distributor

Click to View Pricing, Inventory, Delivery & Lifecycle Information:

Amphenol:

[MDBRE15PMAN0](#) [MDBRA26PMJN0](#) [MDBRE09PMAN0](#) [MDBE09SE760](#) [MDBRE15SEJNO](#) [MDB227093205BP](#)
[MDBRE09SMAN0](#) [MHDRA11130](#) [MDBRE09PEJNO](#) [MDBRA26PMAN0](#) [MDBRE15PEJNO](#) [MDBRE15SEAN0](#)
[MDBRE15SMJNO](#) [MDBRE15PMJNO](#) [MDBE09SM860](#) [MDBRE15PEAN0](#) [MDBRE09PMJNO](#) [MDBRE09SEAN0](#)
[MDBE09PE760](#) [MDBRE09SEJNO](#) [MDBRE09PEAN0](#) [MDBB25SE765](#) [MDBRA26PEAN0](#) [MDBRA26PEJNO](#)
[MDBRE15SMAN0](#) [MDBRE09SMJNO](#)