

Description

Developed in the late 1950's, TNC is a threaded version of the BNC. TNC stands for Threaded Neill Concelman and is named after Amphenol engineer Carl Concelman. This series features screw threads for mating. TNC are miniature, threaded weatherproof units with a constant 50 ohm impedance and operate from 0-11 GHz.

There are two families of TNC connectors:

- Standard
- Reverse Polarity

They are an ideal choice for use in cellular and mobile communications, and test and measurement equipment. They are also widely used in airframe, aerospace and radar applications where extreme vibration is a factor.

Cable connectors range from RG6 to RG179 and include LMR low loss cable.

Features/Benefits

- Threaded coupling interface ensures connector will not decouple in vibration-intensive applications.
- Many TNC connectors are recognized under the component program of Underwriter's Laboratories and have undergone stringent testing from an independent laboratory.
- Performance from 0-11 GHz operates in many applications.

Applications

- Antennas
- Automotive (Cell Phones)
- Base Stations
- Cable Assemblies
- Components
- Computer Networks/LANs
- Instrumentation
- Mil/Aero
- Radar
- Telecom



TNC

Specifications	140
Plugs	141-142
Angle Plugs & Jacks	143-144
PCB Receptacles	145-147

ELECTRICAL

Impedance	50 ohms nominal
Frequency range	0-11 GHz
Voltage rating	500 volts peak
Dielectric withstanding voltage	1,500 volts rms.
VSWR	M39012 straight connectors: 1.3 max. 0-11 GHz M39012 right angle: 1.35 max. 0-11 GHz
Other (MIL-C-39012 cable connectors)	Contact resistance: center contact 1.5 milliohm outer contact 0.2 milliohm Braid to body 0.1 milliohm RF leakage: -60 dB minimum at 3 GHz Insertion loss: 0.18 dB at 9 GHz Insulation resistance: 5000 megohms (min.)

MILITARY SPECIFICATIONS

MIL-C-39012	Where applicable
-------------	------------------

* Amphenol TNC connectors are classified as weatherproof only when used in combination with other Amphenol TNC connectors.

MECHANICAL

Mating	7/16 threaded coupling
Cable affixment (braid or jacket)	All crimps: hex braid crimp. Clamps: screw-thread nut and braid clamp.
Cable affixment (center conductor)	Crimps: crimp or solder All others: solder only
Captivated contact	All crimps Others: where specified.
Cable retention	Clamps: 20-50 lbs. Crimps: 20-100 lbs.

MATERIAL

Center contacts	Male: Brass; female beryllium copper or phosphor bronze. Silver or gold plated
Other metal parts	Brass: Nickel finish except M39012 silver.
Insulators	TFE, Delrin
Clamp gaskets	Synthetic rubber, Silicone rubber
Crimp ferrule	Copper

ENVIRONMENTAL

Temperature range	- 65°C to + 165°C
Weatherproof	Clamps with clamp gaskets. Other Crimps with heat-shrink tubing.
Hermetic seals	Pass helium leak test of 2×10^{-8} cc/sec
Shock	MIL-Std. 202 method 202
Vibration	MIL-Std. 202 method 204 (test cond. D)
Moisture resistance	MIL-Std. 202 method 106
Corrosion	MIL-Std. 202 method 101 (test cond. B)
Temperature cycling	MIL-Std. 202 method 102 (test cond. D)
Altitude	MIL-Std. 202 method 105 (test cond. C)

* These characteristics are typical and may not apply to all connectors.

PLUG

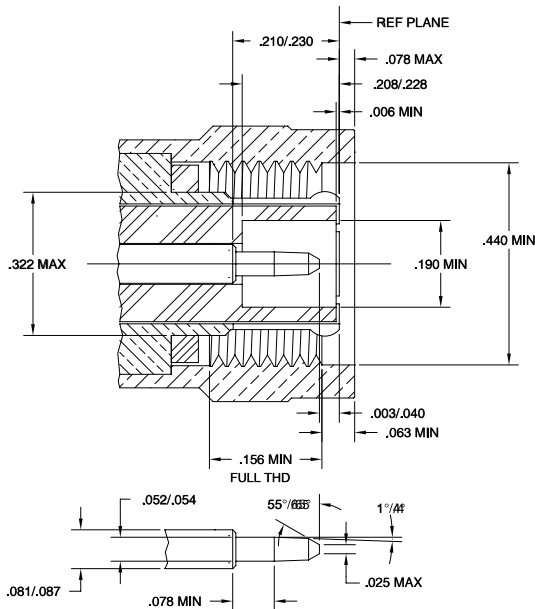

JACK

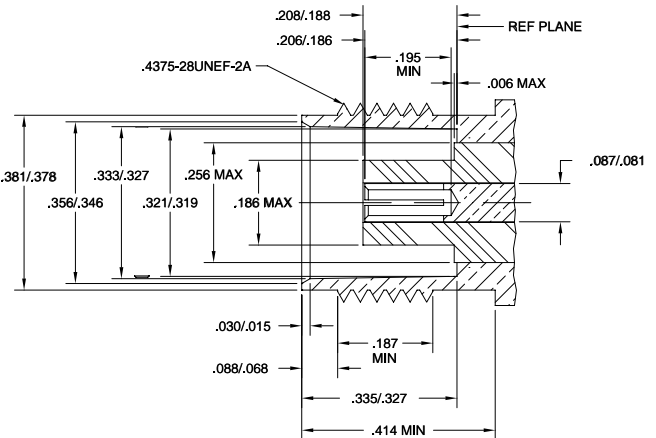

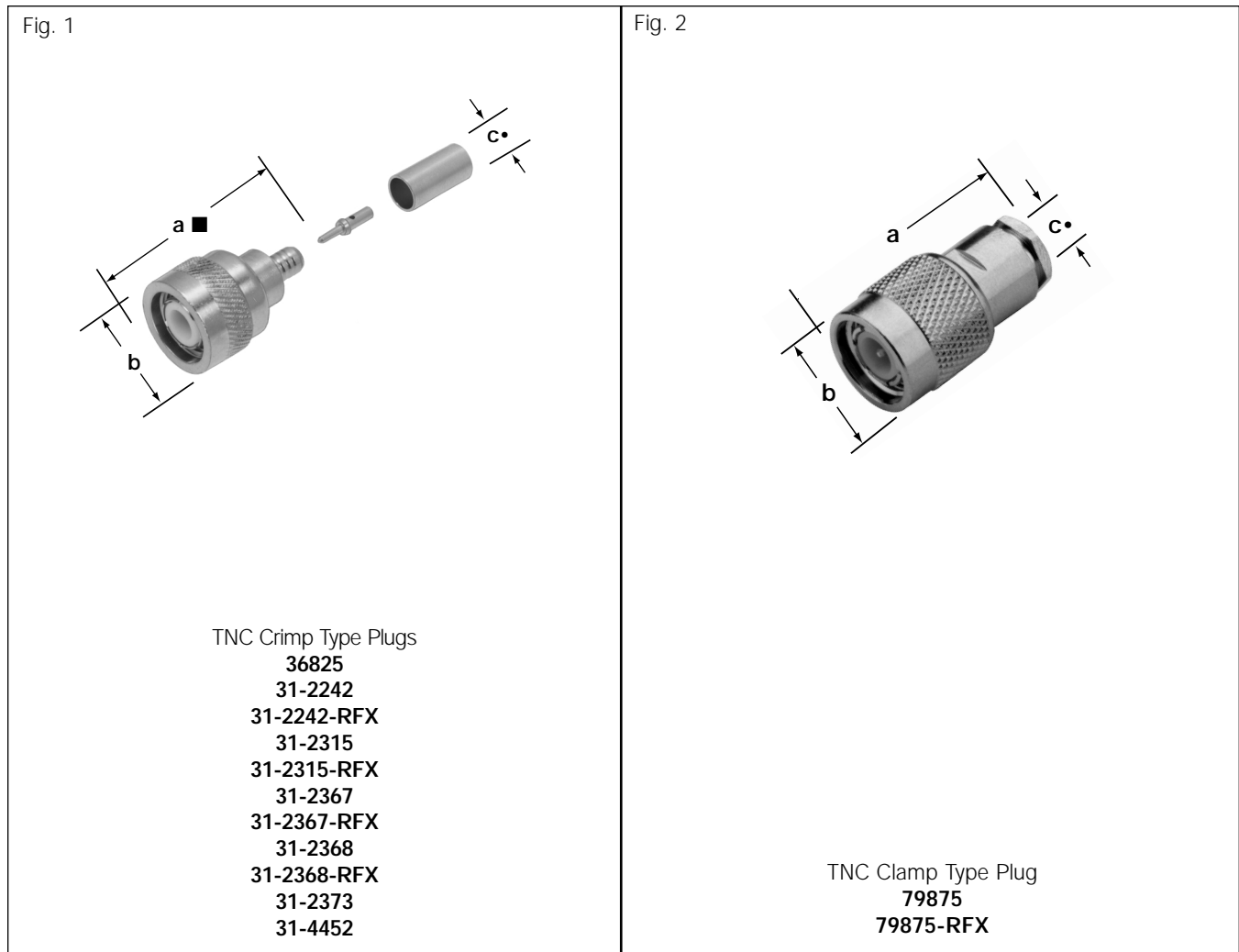

TNC STRAIGHT PLUGS

Cable RG-/U	Conn. Type	Cable Attachment		Dimensions, inches (millimeters)			Notes			Military Number	Amphenol Number	Fig.
		Outer	Inner	a	b	c ●	CAI	Plt.	Ins.			
58, 141	Plug	Crimp	Crimp	1.12(28.6)■	.610(15.5)	.206(5.2)	C36	P15	D1	—	36825	1
	Plug	Crimp	Crimp	1.12(28.6)■	.610(15.5)	.206(5.2)	C36	P15	D1	M23329/4-01,4-03	31-2367	1
	Plug	Crimp	Crimp	1.12(28.6)■	.610(15.5)	.206(5.2)	C36	P7	D23	—	31-2367-RFX	1
59, 62	Plug	Crimp	Crimp	1.13(28.7)■	.610(15.5)	.261(6.6)	C36	P15	D1	M23329/4-05	31-2368	1 ▲
142, 223	Plug	Crimp	Crimp	1.12(28.6)■	.562(14.3)	.220(5.6)	C36	P15	D1	M23329/4-02,4-04	31-2373	1 ▲
142, 400	Plug	Crimp	Crimp	1.12(28.6)■	.500(12.7)	.220(5.6)	C36	P34	D1	M39012/26-0503	31-4452*	1
179, 187	Plug	Crimp	Crimp	1.19(30.2)■	.610(15.5)	.120(3.0)	C36	P7	D1	—	31-2242	1 ▲
174, 188	Plug	Crimp	Crimp	1.19(30.2)■	.610(15.5)	.115(2.9)	C36	P7	D1	—	31-2315	1
174, 188, 316	Plug	Crimp	Crimp	1.19(30.2)■	.517(13.1)	.106(2.7)	C36	P7	D23	—	31-2315-RFX	1
179, 187	Plug	Crimp	Crimp	1.19(30.2)■	.517(13.1)	.106(2.7)	C36	P7	D23	—	31-2242-RFX	1
59, 62	Plug	Crimp	Crimp	1.17(29.7)■	.517(13.1)	.260(6.6)	C36	P7	D23	—	31-2368-RFX	1
58, 142A	Plug	Clamp	Solder	1.07(27.1)■	.827(21.0)	.212(5.4)	C36	P7	D23	—	79875-RFX	2
55, 58, 141, 142, 223, 400	Plug	Clamp	Solder	1.06(27.0)	.610(15.5)	.224(5.7)	C34	P1	D23	—	79875*	2

* recognized under the component program of U.L., Inc. ▲ distributor stocked ■ includes outer ferrule

Fig. 1

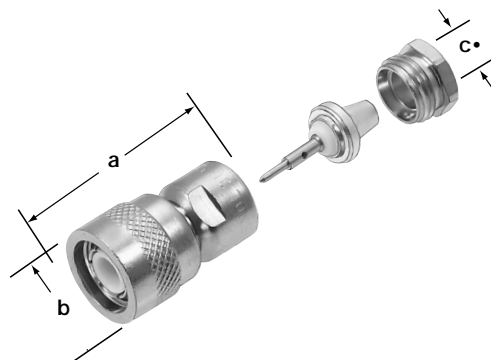

TNC QUICKTRIM® Plug
31-5061

TNC STRAIGHT PLUGS

Cable RG-/U	Conn. Type	Cable Attachment		Dimensions, inches (millimeters)			Notes			Military Number	Amphenol Number	Fig.
		Outer	Inner	a	b	c •	CAI	Plt.	Ins.			
59, 62	Plug	QUICKTRIM®		1.03(26.2)	.610(15.5)	.252(6.4)	C37	P15	D1	—	31-5061	1

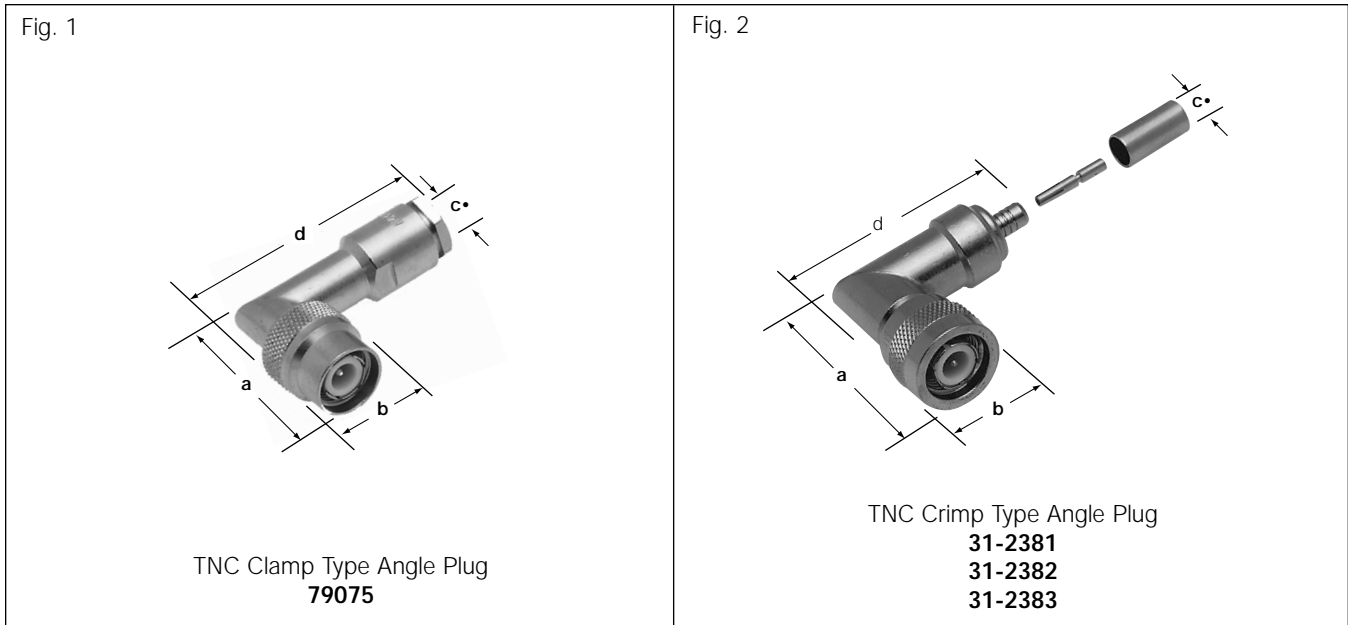

TNC ANGLE PLUGS & JACKS

Cable RG-/U	Conn. Type	Cable Attachment		Dimensions, inches (millimeters)				Notes			Military Number	Amphenol Number	Fig.
		Outer	Inner	a	b	c •	d	CAI	Plt.	Ins.			
55, 58, 141 142, 223, 400	Angle Plug	Clamp	Solder	1.12(28.6)	.610(15.5)	.224(5.7)	1.58(40.1)	C34	P1	D1	—	79075 *	1
55, 142, 223, 400	Angle Plug	Crimp	Crimp	1.19(30.2)	.562(14.3)	.220(5.6)	1.58(40.1)■	C36	P17	D1	—	31-2381	2
58, 141	Angle Plug	Crimp	Crimp	1.19(30.2)	.562(14.3)	.206(5.2)	1.58(40.1)	C36	P17	D1	—	31-2382	2 ▲
62	Angle Plug	Crimp	Crimp	1.19(30.2)	.562(14.3)	.261(6.6)	1.58(40.1)	C36	P17	D1	—	31-2383	2

* recognized under the component program of U.L., Inc. • accommodates cable diameter ■ includes outer ferrule ▲ distributor stocked

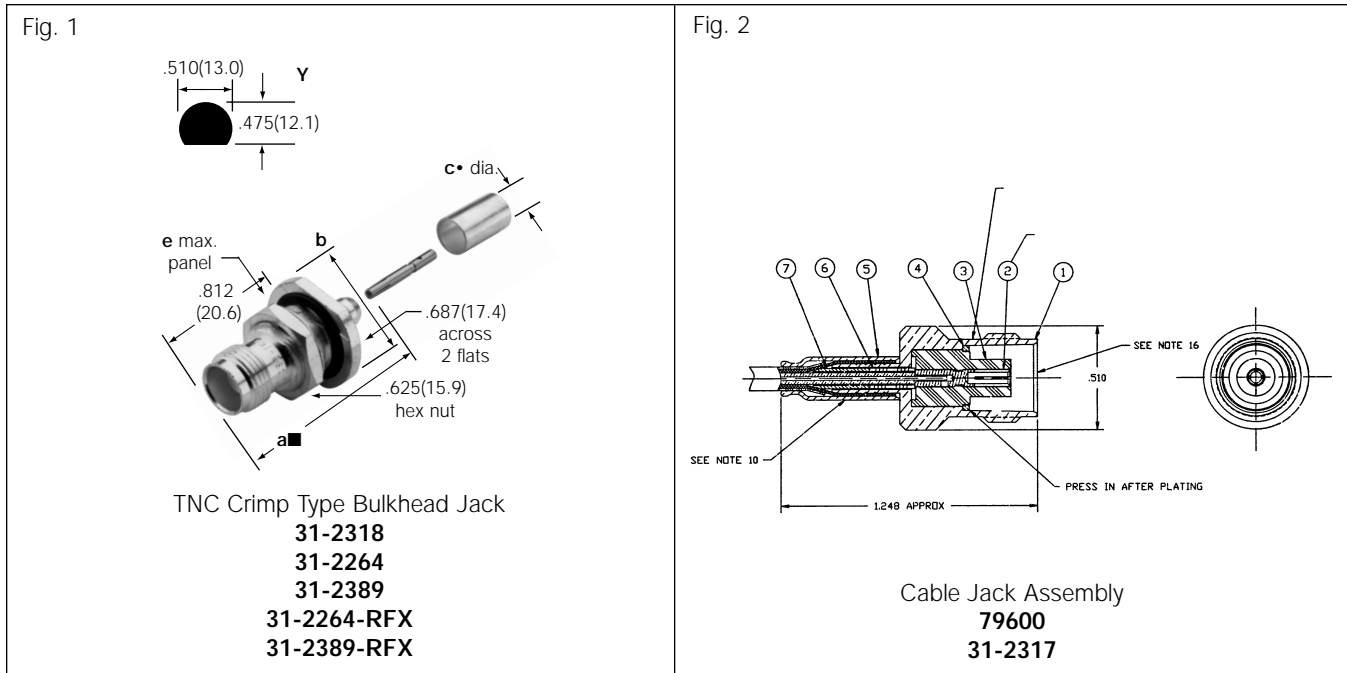

TNC ANGLE JACKS

Cable RG-U	Conn. Type	Cable Attachment		Dimensions, inches (millimeters)				Notes			Military Number	Amphenol Number	Fig.
		Outer	Inner	a	b	c •	e	CAI	Plt.	Ins.			
59, 62, 140, 210	Blkh. Jack	Crimp	Crimp	1.417	.687	.261	.160(4.1)	C36	P34	D1	—	31-2264	1
58, 141A	Blkh. Jack	Crimp	Crimp	1.407	.625	.206	.240(6.1)	C36	P15	D1	—	31-2389	1
59	Blkh. Jack	Crimp	Crimp	1.38	.510	.260	.138(3.5)	C36	P15	D23	—	31-2264-RFX	1
59, 62	Blkh. Jack	Crimp	Crimp	1.19	.470	.123	.138(3.5)	C36	P15	D23	—	31-2389-RFX	1
174, 188, 316	Blkh. Jack	Crimp	Crimp	1.31(33.3)*	.795(20.2)	.115(2.9)	.115(2.9)	C36	P15	D1	—	31-2318 *	1
58	Straight Cable Plugs	Clamp	Solder	1.25	.625	.562	—	C34	P17	D1	—	79600	2
174, 188, 316	Straight Cable Plug	Crimp	Crimp	1.248	.510	.261	—	C36	P15	D1	—	31-2317	2

* Recognized under the component program of U.L., Inc.

▪ Includes outer ferrule

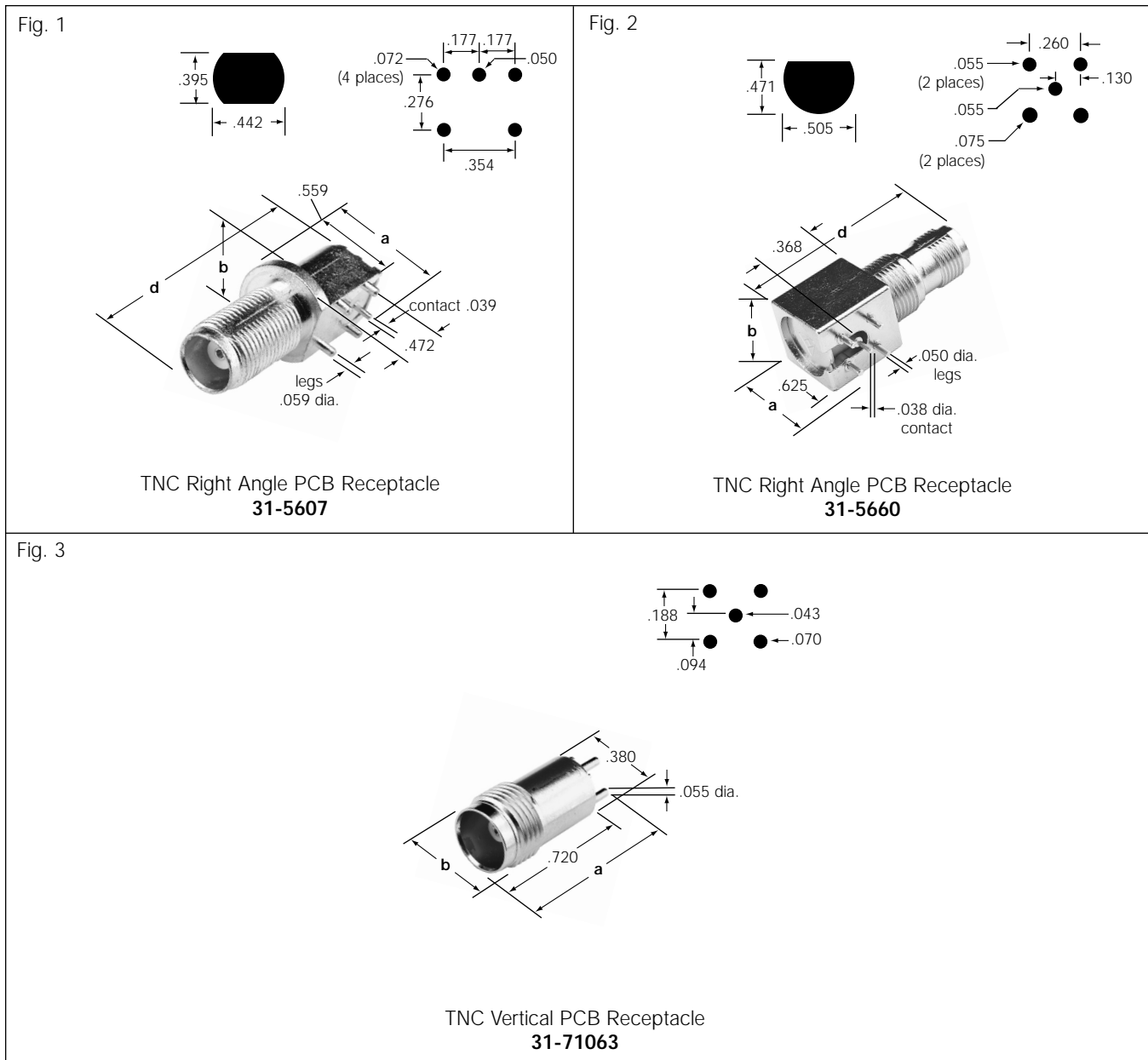

TNC PRINTED CIRCUIT BOARD RECEPTACLES

Description	Dimensions, inches (millimeters)			Notes		Amphenol Number	Fig.
	a	b	d	Pit.	Ins.		
TNC Right Angle Printed Circuit Board Receptacle	.657 (16.7)	.642 (16.3)	1.366 (34.7)	P36/P27	D1	31-5607	1
TNC Right Angle Printed Circuit Board Receptacle	.756 (19.2)	.580 (14.7)	1.500 (38.1)	P6	D1/31	31-5660	2 ▲
TNC Vertical Printed Circuit Board Receptacle	.880(22.4)	.438 (11.1)	—	P15	D1	31-71063	3

▲ distributor stocked

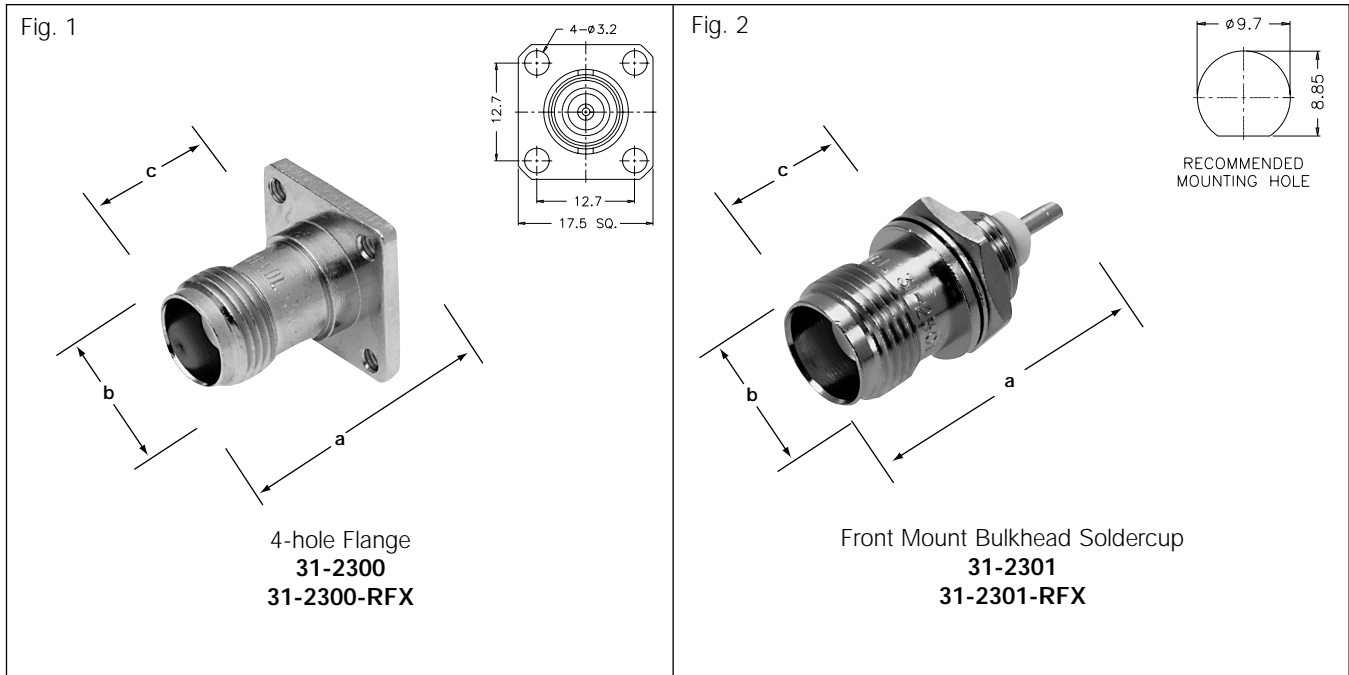

BNC BULKHEAD CABLE JACKS

Description	Dimensions, inches (millimeters)					Plt.	Ins.	Amphenol	Fig.
	a	b	c	d	e				
4-hole flange	.1064	.625	.125	.687	.500	P7	D1	31-2300	1
4-hole flange	1.063	.500	.500	—	—	P7	D1	31-2300-RFX	1
Front mount blkh Soldercup	1.05	.187	.090	.688	.500	P7	D1	31-2301	1
Front mount blkh Soldercup	.860	.490	.425	—	—	P7	D1	31-2301-RFX	2

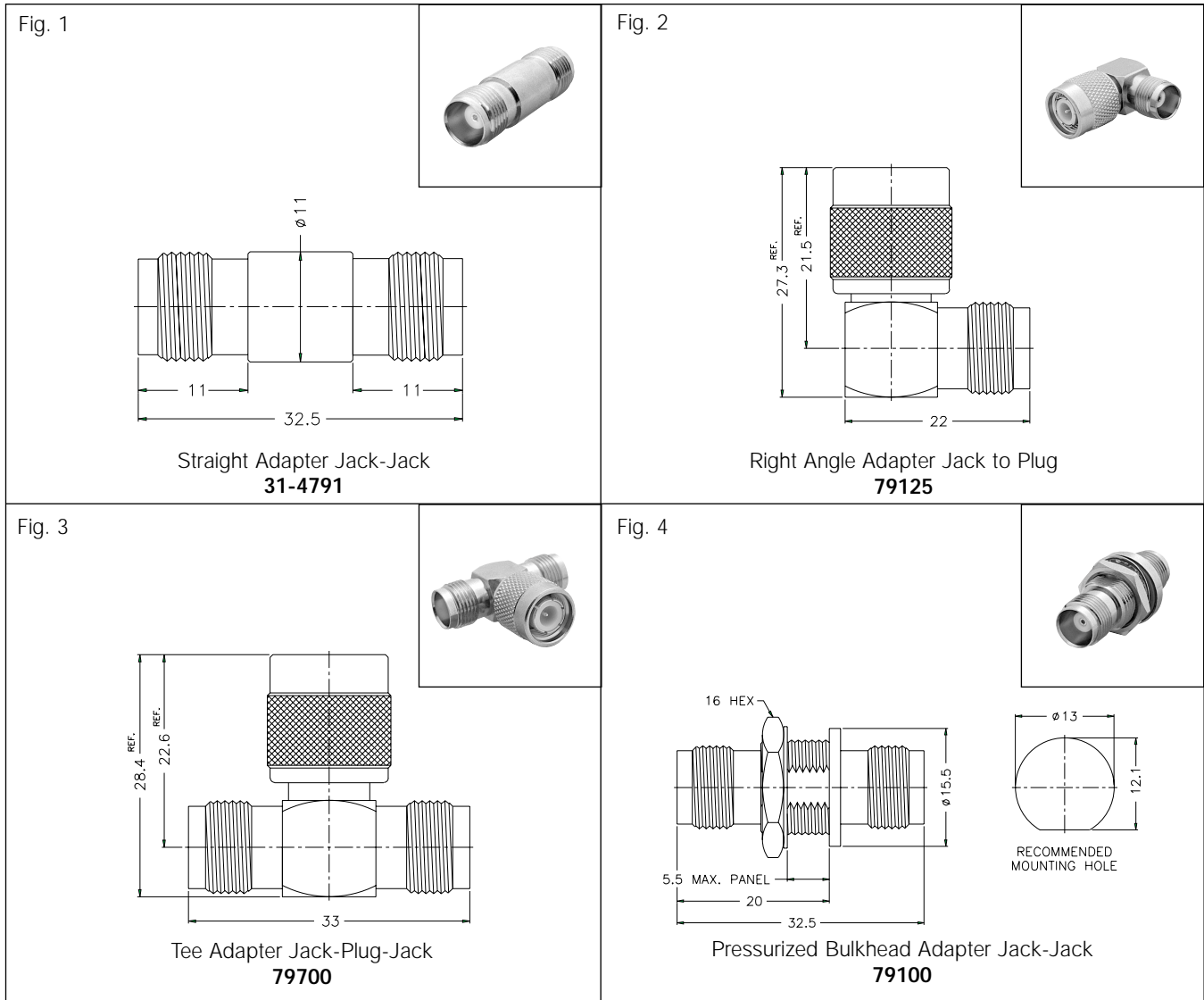

IN SERIES ADAPTERS

Description	Dimensions, inches (millimeters)		Body	Contact	Amphenol	Fig.
	a	b				
Straight Adapter Jack-Jack	1.28 (32.5)	.437 (11.1)	Brass	P7	31-4791	1
Right Angle Adapter Jack to Plug	1.03 (26.1)	.625 (15.9)	Brass	P7	79125	2
Tee Adapter Jack-Plug-Jack	1.28 (32.5)	.96 (24.4)	Brass	P7	79700	3
Bulkhead Adapters (pressurized) Jack-Jack	1.41 (35.8)	.750 (19.1)	Brass	P7	79100	4