

DWG NO. 36-00029-06 SHI REV E

PROPRIETARY DATA!
This document and information contained here may not be reproduced, used or disclosed without prior written permission of WESTCOR a division of VICOR Corporation.

REVISIONS				
ECO	REV	DESCRIPTION	DATE	APPROVED
687	A	CHANGED MATERIAL	7-25-97	RBD
730	B	CHG: NOTE 2.1, WAS: L = 56 UH	12-18-97	RBD
1023	C	CHG: NOTES 2.1, & 3.3 PER ECO	05-15-00	RBD
---	C1	ADD PERMACORE 87-9040-26	11/10/00	RBD
---	C2	CERT. OF COMPLIANCE CHANGES	6/5/03	RD
1417	C3	ADD SOURCE SHANGHI SUPER ELECT	09/07/04	RBD
1462	D	ADDED ROHS SPEC NOTE	06/21/05	LGK
1543	E	TAPE # 1350F WAS # 1298	09/01/05	LGK

NOTES: UNLESS OTHERWISE SPECIFIED

1. MATERIALS: UL RECOGNIZED 94V-2 FLAMMABILITY RATING CLASS B (130°C) REQUIRED

1.1 CORE: TOROID, $\mu = 5000$

MAGNETICS: ZJ-43806-TC OR
PERMACOR: 87-9040-26 OR
SHANGHAI SUPER LIGHT ELECTRONICS COMPONENTS LTD.
P/N: T38X19X6.35-C. MATERIAL RSK (CAN BE USED IF ROHS COMPLIANT)

1.2 WIRE: U.L. RECOGNIZED 130°C MINIMUM RATING MAGNET WIRE, APPROVED MFR ESSEX
OTHER MFR HAS TO BE ROHS COMPLIANT CERTIFIED BEFORE USE.

1.3 OUTER WRAP: 3M H69 OR #1350F.

1.4 MATERIAL CERTIFICATE OF COMPLIANCE REQUIRED

2. SPECIFICATIONS:

2.1 L = 52 uH MIN/COIL (1 KHZ, 4Vrms)

2.2 ICR = 4 MOHMS MAX/COIL

2.3 POWER LOSS = 5.2W MAX @ 80A/COIL

2.4 HI-POT TEST COIL TO COIL, 250VDC TO INSURE INTEGRITY OF WINDING
INSULATION COVERING HAS NOT BEEN BREACHED.

3. CONSTRUCTION

3.1 WIND COILS EVENLY SPACED (NOTE POLARITY)

3.2 REMOVE INSULATION AND TIN LEADS APPROX FLUSH WITH THE COIL AS SHOWN
(I.E. COIL MUST REST FLAT ON PCB). LEADS MUST BE TANGENT TO THE CORE.

3.3 WRAP INDUCTOR WITH TAPE, (PER NOTE 1.3). MARK PART NUMBER AND REVISION
IN (BLACK) APPROX. WHERE SHOWN, USING A PERMANENT MARKING METHOD.

3.4 COIL LEADS MUST FUNCTION FIT INTO A JIG MADE PER THE DIMENSIONS SHOWN
ON "FORMING JIG MTG HOLE PATTERN" TO INSURE PROPER POSITION AND ANGLE.

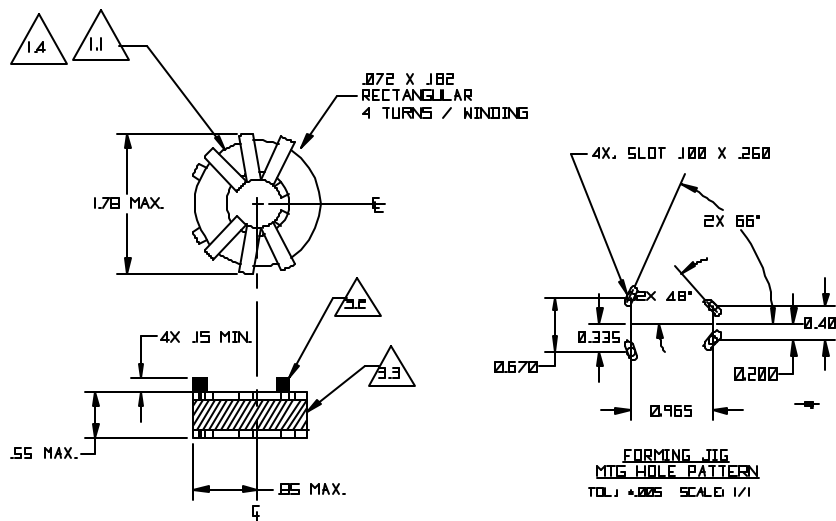

NOTE: CERTIFICATION OF MATERIAL COMPLIANCE REQUIRED.
COMPLETED ASSEMBLY MUST BE (ROHS) COMPLIANT
PER VICOR SPEC CST-0001.

		UNLESS OTHERWISE SPECIFIED DIMENSIONS ARE IN INCHES TOLERANCES ARE: FRACTIONS DECIMALS ANGLES --- XX ± .05 ± 3° XXX ± .025	CONTRACT NO. ---		WESTCOR a division of VICOR Corp.	
		MATERIAL SEE NOTES	DRAWN M.E. STURFALDE 12/28/98		IND COMMON MODE 70uH 80A	
---		FINISH ---	CHECKED LJING 7/25/97		SIZE B	CAGE CODE ---
NEXT ASSY USED ON			APPROVED RUBRABING 7/25/97		INS NO. 36-00029-06	REV E
APPLICATION		DO NOT SCALE DRAWING	DESIGNED R.CABALLERO 12/03/96		SCALE NTS	FILENAME 88029-06.DWG
					SHEET	1 OF 1

Mouser Electronics

Authorized Distributor

Click to View Pricing, Inventory, Delivery & Lifecycle Information:

[Vicor:](#)

[36-00029-06](#)