

Micropower low-voltage, rail-to-rail comparators

Datasheet - production data

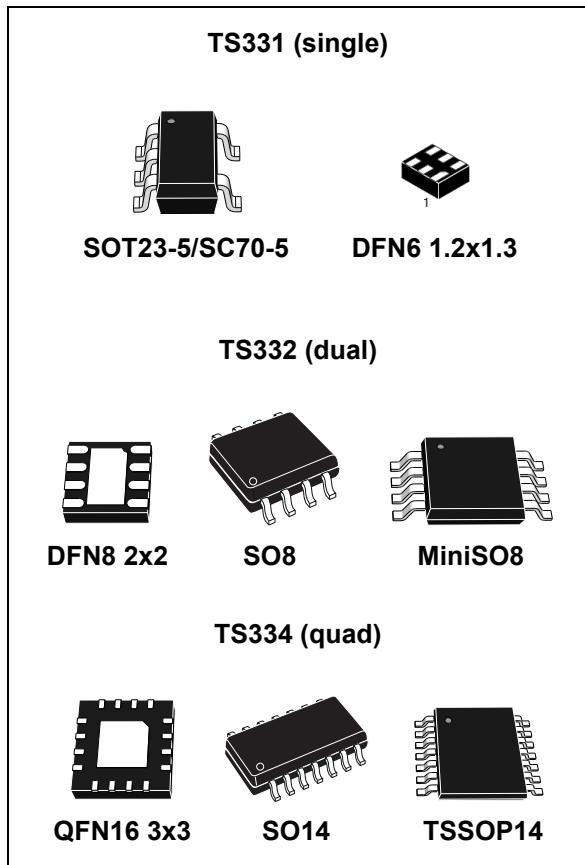

Applications

- Mobile phones
- Notebooks and PDAs
- Battery-supplied electronics
- General-purpose portable devices
- General-purpose low voltage applications

Description

The TS331, TS332 and TS334 are single, dual and quad micropower and low-voltage comparators. They can operate with a supply voltage ranging from 1.6 V to 5 V with a typical current consumption as low as 20 μ A. In addition, rail-to-rail inputs make them a perfect choice for low-voltage applications.

Their availability in tiny packages is a real advantage for overcoming space constraints.

The TS33x are specified for temperatures between $-40\text{ }^{\circ}\text{C}$ to $+125\text{ }^{\circ}\text{C}$, making them ideal for a wide range of applications.

Features

- Supply operation from 1.6 V to 5 V
- Low current consumption: 20 μ A
- Rail-to-rail inputs
- Wide temperature range: $-40\text{ }^{\circ}\text{C}$ to $+125\text{ }^{\circ}\text{C}$
- Low output saturation voltage
- Low propagation delay: 210 ns
- Open-drain output
- ESD tolerance: 2 kV HBM/200 V MM
- SMD packages
- Automotive qualified

Contents

- 1 Package pin connections 3**
- 2 Absolute maximum ratings and operating conditions 4**
- 3 Electrical characteristics 6**
- 4 Package information 13**
 - 4.1 SOT23-5 package information 14
 - 4.2 SC70-5 (SOT323-5) package information 15
 - 4.3 DFN6 1.2x1.3 package information 16
 - 4.4 DFN8 2x2 package information 17
 - 4.5 SO8 package information 19
 - 4.6 MiniSO8 package information 20
 - 4.7 QFN16 3x3 package information 21
 - 4.8 SO14 package information 23
 - 4.9 TSSOP14 package information 24
- 5 Ordering information 25**
- 6 Revision history 26**

1 Package pin connections

Figure 1. Pin connections for each package (top view)

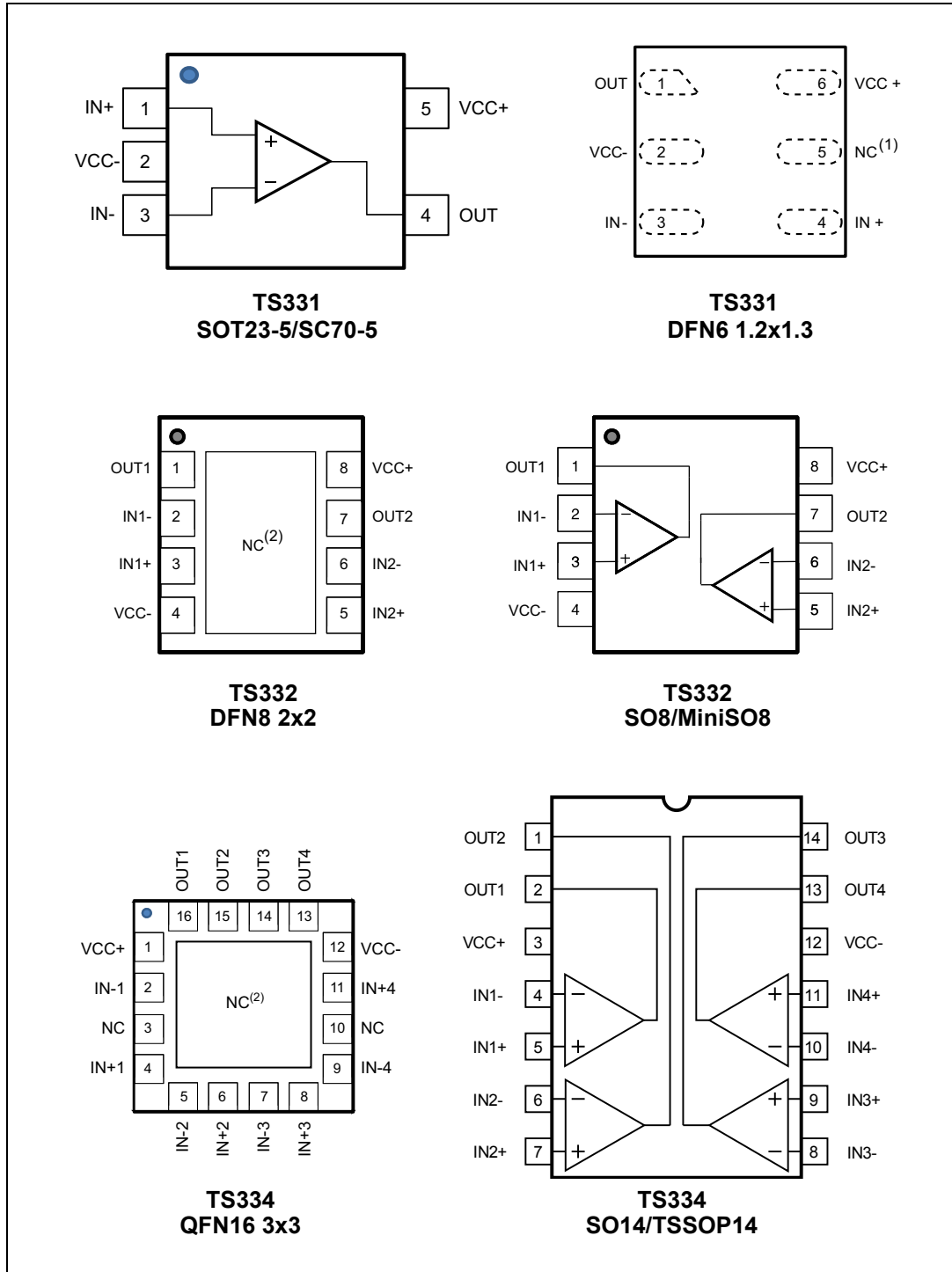

1. NC = not connected
2. The exposed pads of the DFN8 2x2 and the QFN16 3x3 can be connected to VCC- or left floating.

2 Absolute maximum ratings and operating conditions

Table 1. Absolute maximum ratings

Symbol	Parameter	Value	Unit
V_{CC}	Supply voltage ⁽¹⁾	5.5	V
V_{ID}	Differential input voltage	± 5.5	
V_{IN}	Input voltage range	$(V_{CC-}) - 0.3$ to $(V_{CC+}) + 0.3$	
V_{out}	Output voltage ⁽¹⁾	5.5	
R_{thja}	Thermal resistance junction to ambient ⁽²⁾		°C/W
	SOT23-5	250	
	SC70-5	205	
	DFN6 1.2x1.3	40	
	DFN8 2x2	57	
	SO8	125	
	MiniSO8	190	
	QFN16 3x3	39	
SO14	105		
TSSOP14	100		
R_{thjc}	Thermal resistance junction to case ⁽²⁾		
	SOT23-5	81	
	SC70-5	172	
	SO8	40	
	MiniSO8	39	
	QFN16 3x3	5	
	SO14	31	
TSSOP14	32		
T_{stg}	Storage temperature	-65 to +150	°C
T_j	Junction temperature	150	
T_{LEAD}	Lead temperature (soldering 10 seconds)	260	
ESD	Human body model (HBM) ⁽³⁾	2000	V
	Machine model (MM) ⁽⁴⁾	200	
	Charged device model (CDM) ⁽⁵⁾	1500	
	Latchup immunity	200	mA

1. All voltage values, except differential voltage, are referenced to V_{CC-}
2. Short-circuits can cause excessive heating. These values are typical
3. According to JEDEC standard JESD22-A114F.
4. According to JEDEC standard JESD22-A115A.
5. According to ANSI/ESD STM5.3.1.

Table 2. Operating conditions

Symbol	Parameter	Value	Unit
T_{oper}	Operating temperature range	-40 to +125	°C
V_{CC}	Supply voltage (V_{CC+}) - (V_{CC-}) $-40^{\circ}\text{C} < T_{amb} < +125^{\circ}\text{C}$	1.6 to 5.0	V
V_{ICM}	Common mode input voltage range $T_{amb} = +25^{\circ}\text{C}$ $-40^{\circ}\text{C} < T_{amb} < +125^{\circ}\text{C}$	$(V_{CC-}) - 0.2$ to $(V_{CC+}) + 0.2$ (V_{CC-}) to (V_{CC+})	

3 Electrical characteristics

Table 3. $V_{CC+} = +1.8\text{ V}$, $V_{CC-} = 0\text{ V}$, $T_{amb} = +25^\circ\text{C}$ (unless otherwise specified)

Symbol	Parameter	Test conditions	Min.	Typ.	Max.	Unit
V_{IO}	Input offset voltage			0.5	5	mV
		$-40^\circ\text{C} < T_{amb} < +125^\circ\text{C}$			6	
$\Delta V_{IO}/\Delta T$	Input offset voltage drift	$-40^\circ\text{C} < T_{amb} < +125^\circ\text{C}$		4.5		$\mu\text{V}/^\circ\text{C}$
I_{IB}	Input bias current ⁽¹⁾			25	40	nA
		$-40^\circ\text{C} < T_{amb} < +125^\circ\text{C}$			100	
I_{IO}	Input offset current ⁽¹⁾			1	10	nA
		$-40^\circ\text{C} < T_{amb} < +125^\circ\text{C}$			100	
I_{CC}	Supply current	No load, output low, $V_{ICM} = 0\text{ V}$		20	26	μA
		$-40^\circ\text{C} < T_{amb} < +125^\circ\text{C}$			30	
		No load, output high, $V_{ICM} = 0\text{ V}$		22	29	
		$-40^\circ\text{C} < T_{amb} < +125^\circ\text{C}$			33	
I_{OH}	Output current leakage	$V_{OUT} = V_{CC+}$		1	10	nA
		$-40^\circ\text{C} < T_{amb} < +125^\circ\text{C}$			500	
V_{OL}	Output voltage low	$I_{SINK} = 1\text{ mA}$		24	30	mV
		$-40^\circ\text{C} < T_{amb} < +125^\circ\text{C}$			50	
I_{SINK}	Output sink current	$V_{OUT} = 1.5\text{ V}$	20	22		mA
		$-40^\circ\text{C} < T_{amb} < +125^\circ\text{C}$	15			
CMRR	Common mode rejection ratio	$0 < V_{ICM} < 1.8\text{ V}$	50	68		dB
TP_{HL}	Propagation delay ⁽²⁾ High to low output level	$V_{ICM} = 0\text{ V}$, $R_L = 5.1\text{ k}\Omega$, $C_L = 50\text{ pF}$, overdrive = 10 mV		300		ns
		$V_{ICM} = 0\text{ V}$, $R_L = 5.1\text{ k}\Omega$, $C_L = 50\text{ pF}$, overdrive = 100 mV		210	310	
TP_{LH}	Propagation delay ⁽³⁾ Low to high output level	$V_{ICM} = 0\text{ V}$, $R_L = 5.1\text{ k}\Omega$, $C_L = 50\text{ pF}$, overdrive = 10 mV		540		ns
		$V_{ICM} = 0\text{ V}$, $R_L = 5.1\text{ k}\Omega$, $C_L = 50\text{ pF}$, overdrive = 100 mV		420	620	

1. Maximum values include unavoidable inaccuracies of the industrial tests.
2. TP_{HL} is measured when the output signal crosses a voltage level at 50% of V_{CC} with the following conditions: inverting input voltage (IN^-) = V_{ICM} and non-inverting input voltage (IN^+) moving from $V_{ICM} + 100\text{ mV}$ to $V_{ICM} - \text{overdrive}$.
3. TP_{LH} is measured when the output signal crosses a voltage level at 50% of V_{CC} with the following conditions: inverting input voltage (IN^-) = V_{ICM} and non-inverting input voltage (IN^+) moving from $V_{ICM} - 100\text{ mV}$ to $V_{ICM} + \text{overdrive}$.

Table 4. $V_{CC+} = +2.7\text{ V}$, $V_{CC-} = 0\text{ V}$, $T_{amb} = +25^\circ\text{C}$ (unless otherwise specified)

Symbol	Parameter	Test conditions	Min.	Typ.	Max.	Unit
V_{IO}	Input offset voltage			0.5	5	mV
		$-40^\circ\text{C} < T_{amb} < +125^\circ\text{C}$			6	
$\Delta V_{IO}/\Delta T$	Input offset voltage drift	$-40^\circ\text{C} < T_{amb} < +125^\circ\text{C}$		3.3		$\mu\text{V}/^\circ\text{C}$
I_{IB}	Input bias current ⁽¹⁾			25	40	nA
		$-40^\circ\text{C} < T_{amb} < +125^\circ\text{C}$			100	
I_{IO}	Input offset current ⁽¹⁾			1	10	nA
		$-40^\circ\text{C} < T_{amb} < +125^\circ\text{C}$			100	
I_{CC}	Supply current	No load, output low, $V_{ICM} = 0\text{ V}$		21	27	μA
		$-40^\circ\text{C} < T_{amb} < +125^\circ\text{C}$			31	
		No load, output high, $V_{ICM} = 0\text{ V}$		23	30	
		$-40^\circ\text{C} < T_{amb} < +125^\circ\text{C}$			34	
I_{OH}	Output current leakage	$V_{OUT} = V_{CC+}$		1	10	nA
		$-40^\circ\text{C} < T_{amb} < +125^\circ\text{C}$			500	
V_{OL}	Output voltage low	$I_{SINK} = 1\text{ mA}$		17	30	mV
		$-40^\circ\text{C} < T_{amb} < +125^\circ\text{C}$			50	
I_{SINK}	Output sink current	$V_{OUT} = 1.5\text{ V}$	40	47		mA
		$-40^\circ\text{C} < T_{amb} < +125^\circ\text{C}$	30			
CMRR	Common mode rejection ratio	$0 < V_{ICM} < 2.7\text{ V}$	54	74		dB
		$-40^\circ\text{C} < T_{amb} < +125^\circ\text{C}$	53			
TP_{HL}	Propagation delay ⁽²⁾ High to low output level	$V_{ICM} = 0\text{ V}$, $R_L = 5.1\text{ k}\Omega$, $C_L = 50\text{ pF}$, overdrive = 10 mV		320		ns
		$V_{ICM} = 0\text{ V}$, $R_L = 5.1\text{ k}\Omega$, $C_L = 50\text{ pF}$, overdrive = 100 mV		220	320	
TP_{LH}	Propagation delay ⁽³⁾ Low to high output level	$V_{ICM} = 0\text{ V}$, $R_L = 5.1\text{ k}\Omega$, $C_L = 50\text{ pF}$, overdrive = 10 mV		550		ns
		$V_{ICM} = 0\text{ V}$, $R_L = 5.1\text{ k}\Omega$, $C_L = 50\text{ pF}$, overdrive = 100 mV		420	640	

1. Maximum values include unavoidable inaccuracies of the industrial tests.
2. TP_{HL} is measured when the output signal crosses a voltage level at 50% of V_{CC} with the following conditions: Inverting input voltage (IN-) = V_{ICM} and non-inverting input voltage (IN+) moving from $V_{ICM} + 100\text{ mV}$ to $V_{ICM} - \text{overdrive}$.
3. TP_{LH} is measured when the output signal crosses a voltage level at 50% of V_{CC} with the following conditions: Inverting input voltage (IN-) = V_{ICM} and non-inverting input voltage (IN+) moving from $V_{ICM} - 100\text{ mV}$ to $V_{ICM} + \text{overdrive}$.

Table 5. $V_{CC+} = +5\text{ V}$, $V_{CC-} = 0\text{ V}$, $T_{amb} = +25^\circ\text{C}$ (unless otherwise specified)

Symbol	Parameter	Test conditions	Min.	Typ.	Max.	Unit
V_{IO}	Input offset voltage			0.5	5	mV
		$-40^\circ\text{C} < T_{amb} < +125^\circ\text{C}$			6	
$\Delta V_{IO}/\Delta T$	Input offset voltage drift	$-40^\circ\text{C} < T_{amb} < +125^\circ\text{C}$		1.3		$\mu\text{V}/^\circ\text{C}$
I_{IB}	Input bias current ⁽¹⁾			30	40	nA
		$-40^\circ\text{C} < T_{amb} < +125^\circ\text{C}$			100	
I_{IO}	Input offset current ⁽¹⁾			1	10	nA
		$-40^\circ\text{C} < T_{amb} < +125^\circ\text{C}$			100	
I_{CC}	Supply current	No load, output low, $V_{ICM} = 0\text{ V}$		23	30	μA
		$-40^\circ\text{C} < T_{amb} < +125^\circ\text{C}$			34	
		No load, output high, $V_{ICM} = 0\text{ V}$		26	34	
		$-40^\circ\text{C} < T_{amb} < +125^\circ\text{C}$			38	
I_{OH}	Output current leakage	$V_{OUT} = V_{CC+}$		1	10	nA
		$-40^\circ\text{C} < T_{amb} < +125^\circ\text{C}$			600	
V_{OL}	Output voltage low	$I_{SINK} = 4\text{ mA}$		48	60	mV
		$-40^\circ\text{C} < T_{amb} < +125^\circ\text{C}$			80	
I_{SINK}	Output sink current	$V_{OUT} = 1.5\text{ V}$	82	93		mA
		$-40^\circ\text{C} < T_{amb} < +125^\circ\text{C}$	60			
A_V	Voltage gain		40	100		V/mV
CMRR	Common mode rejection ratio	$0 < V_{ICM} < 5\text{ V}$	60	79		dB
		$-40^\circ\text{C} < T_{amb} < +125^\circ\text{C}$	58			
SVR	Supply voltage rejection	$\Delta V_{CC} = 1.8\text{ to }5\text{ V}$	56	75		dB
		$-40^\circ\text{C} < T_{amb} < +125^\circ\text{C}$	56			
TP_{HL}	Propagation delay ⁽²⁾ High to low output level	$V_{ICM} = 0\text{ V}$, $R_L = 5.1\text{ k}\Omega$, $C_L = 50\text{ pF}$, overdrive = 10 mV		380		ns
		$V_{ICM} = 0\text{ V}$, $R_L = 5.1\text{ k}\Omega$, $C_L = 50\text{ pF}$, overdrive = 100 mV		270	430	
TP_{LH}	Propagation delay ⁽³⁾ Low to high output level	$V_{ICM} = 0\text{ V}$, $R_L = 5.1\text{ k}\Omega$, $C_L = 50\text{ pF}$, overdrive = 10 mV		570		ns
		$V_{ICM} = 0\text{ V}$, $R_L = 5.1\text{ k}\Omega$, $C_L = 50\text{ pF}$, overdrive = 100 mV		450	720	

1. Maximum values include unavoidable inaccuracies of the industrial tests.
2. TP_{HL} is measured when the output signal crosses a voltage level at 50% of V_{CC} with the following conditions: Inverting input voltage (IN-) = V_{ICM} and non-inverting input voltage (IN+) moving from $V_{ICM} + 100\text{ mV}$ to $V_{ICM} - \text{overdrive}$.
3. TP_{LH} is measured when the output signal crosses a voltage level at 50% of V_{CC} with the following conditions: Inverting input voltage (IN-) = V_{ICM} and non-inverting input voltage (IN+) moving from $V_{ICM} - 100\text{ mV}$ to $V_{ICM} + \text{overdrive}$.

Figure 2. Supply current versus supply voltage with output high, $V_{ICM} = 0\text{ V}$

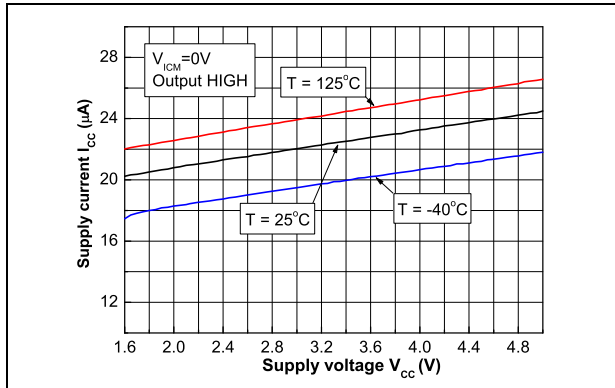

Figure 3. Supply current versus supply voltage with output high, $V_{ICM} = V_{CC}$

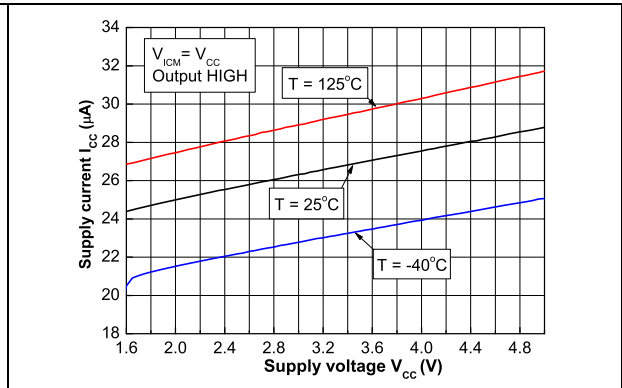

Figure 4. Supply current versus supply voltage with output low, $V_{ICM} = 0\text{ V}$

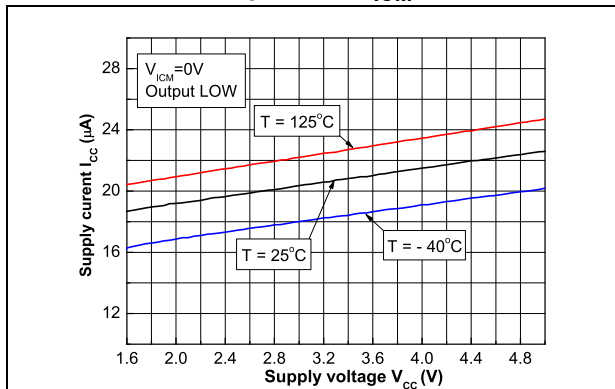

Figure 5. Supply current versus supply voltage with output low, $V_{ICM} = V_{CC}$

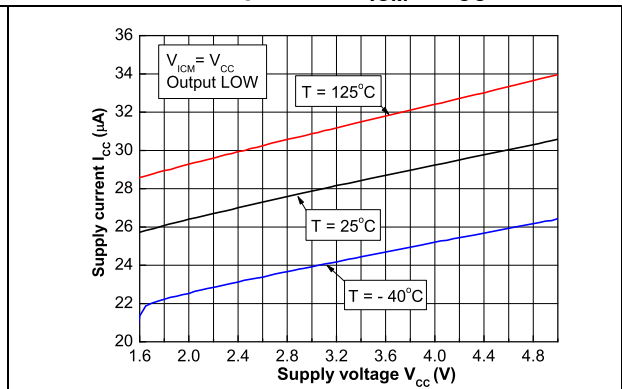

Figure 6. Supply current versus temperature

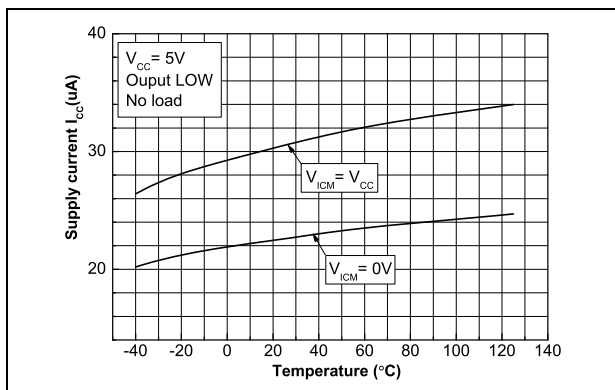

Figure 7. Input bias current versus input common-mode voltage

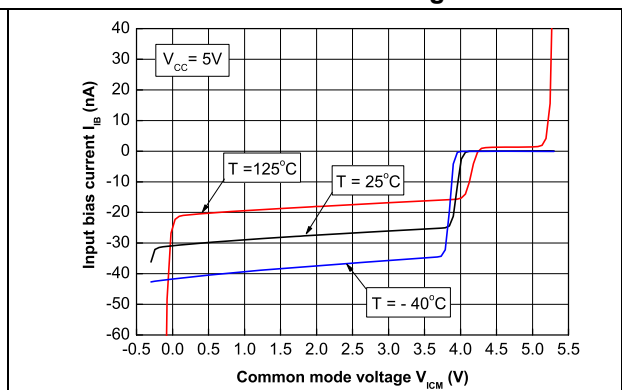

Figure 8. Input current versus differential input voltage

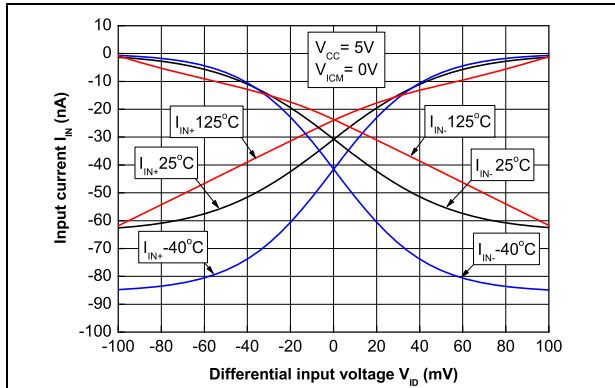

Figure 9. Input offset voltage versus temperature

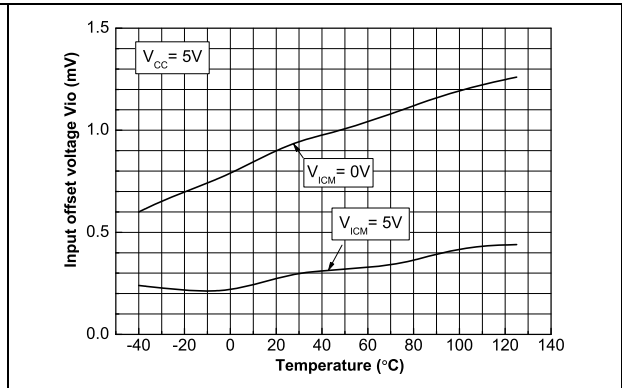

Figure 10. Output voltage versus output sink current, $V_{CC} = 1.8V$

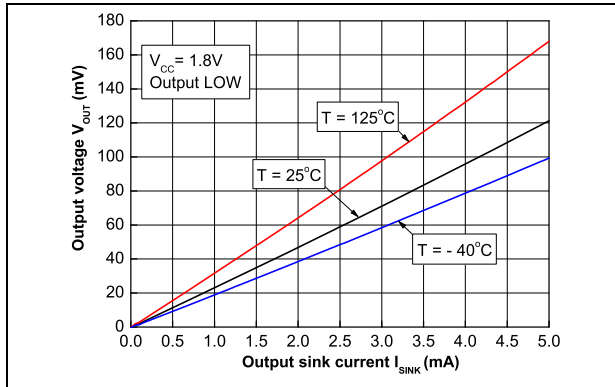

Figure 11. Output voltage versus output sink current, $V_{CC} = 2.7V$

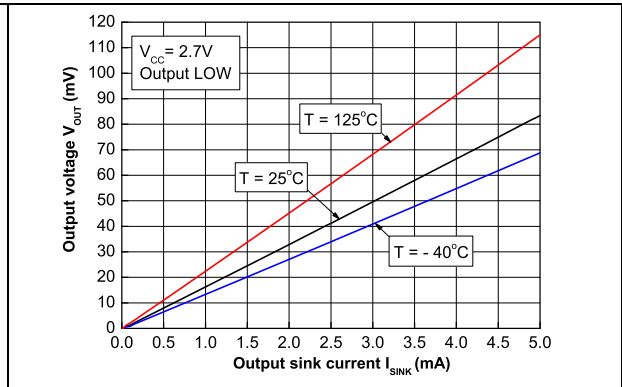

Figure 12. Output voltage versus output sink current, $V_{CC} = 5V$

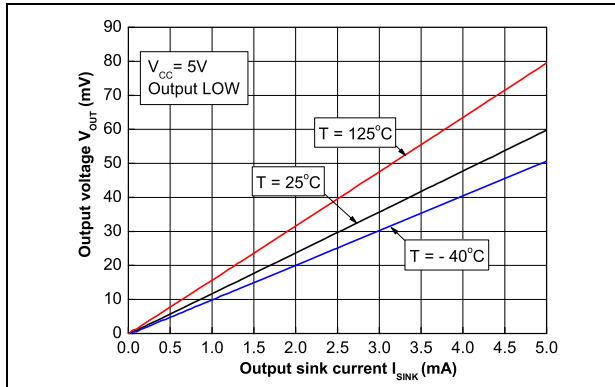

Figure 13. Output sink current versus output voltage

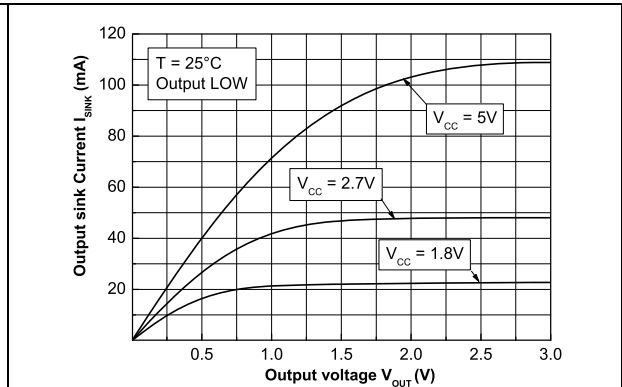

Figure 14. Output voltage versus temperature

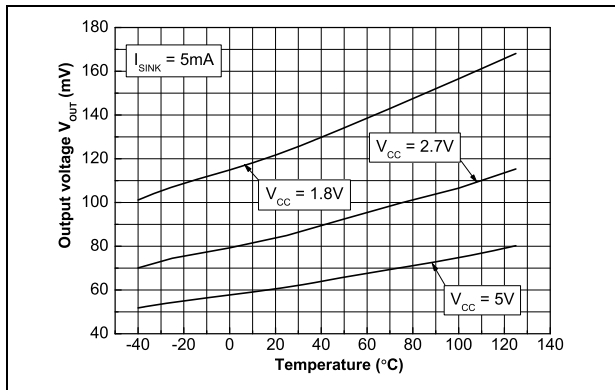

Figure 15. Propagation delay versus overdrive with negative transition, $V_{CC} = 1.8V$

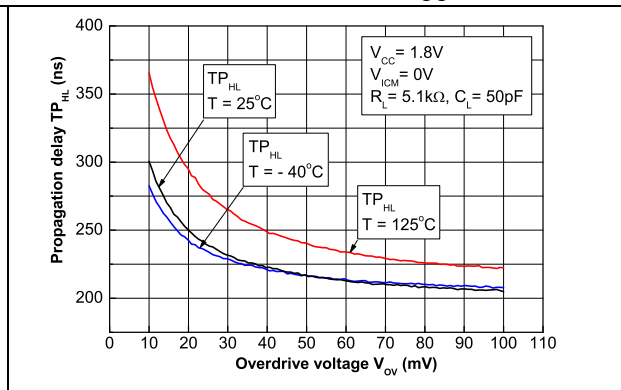

Figure 16. Propagation delay versus overdrive with positive transition, $V_{CC} = 1.8V$

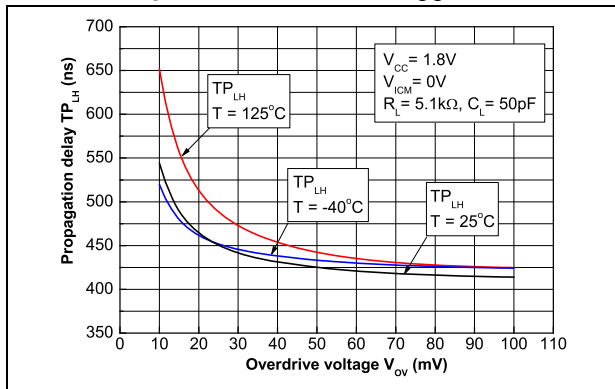

Figure 17. Propagation delay versus common mode voltage, $V_{CC} = 1.8V$

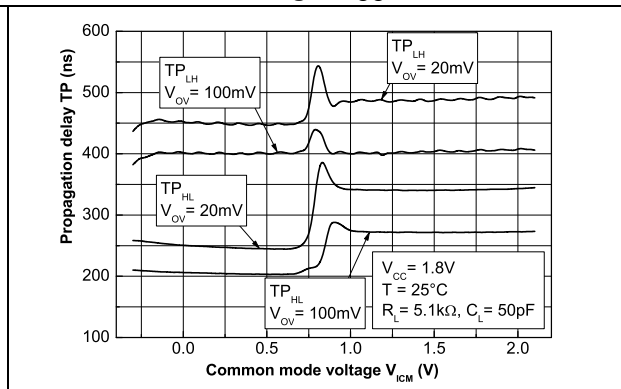

Figure 18. Propagation delay versus overdrive with negative transition, $V_{CC} = 2.7V$

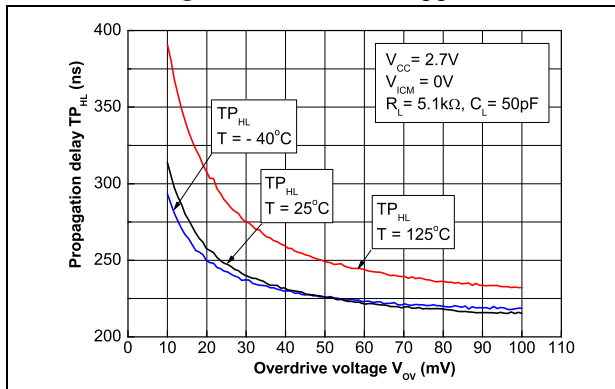

Figure 19. Propagation delay versus overdrive with positive transition, $V_{CC} = 2.7V$

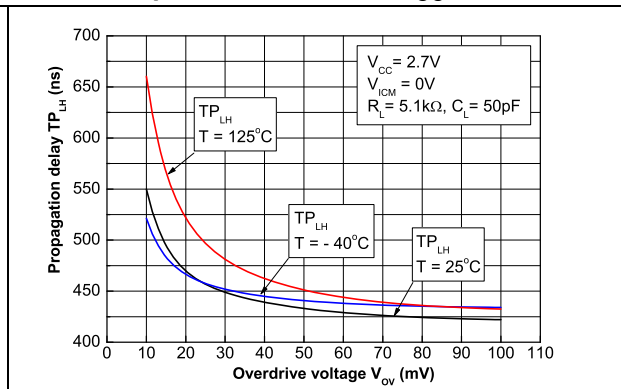

Figure 20. Propagation delay versus common mode voltage, $V_{CC} = 2.7\text{ V}$

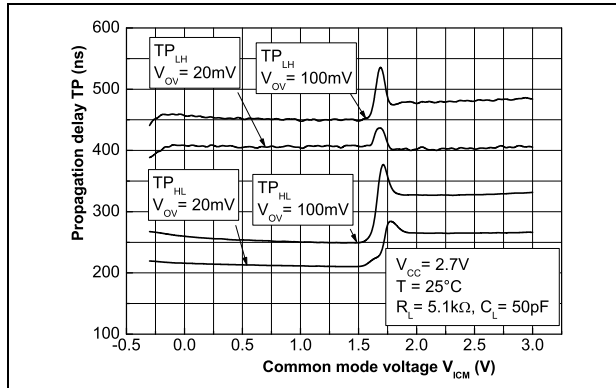

Figure 21. Propagation delay versus overdrive with negative transition, $V_{CC} = 5\text{ V}$

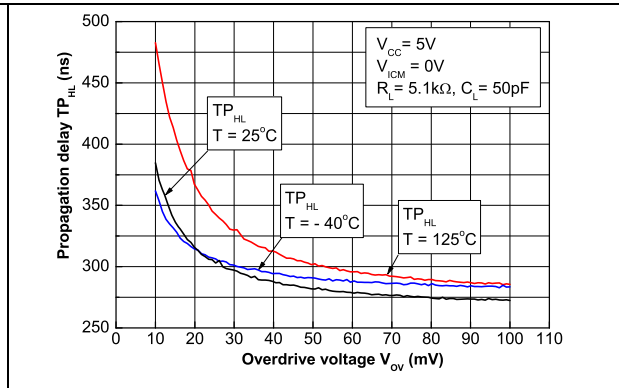

Figure 22. Propagation delay versus overdrive with positive transition, $V_{CC} = 5\text{ V}$

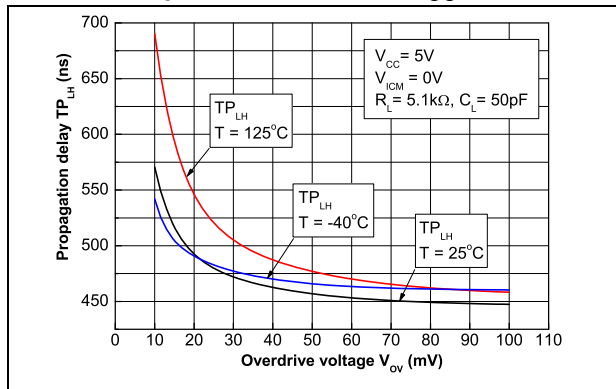

Figure 23. Propagation delay versus common mode voltage, $V_{CC} = 5\text{ V}$

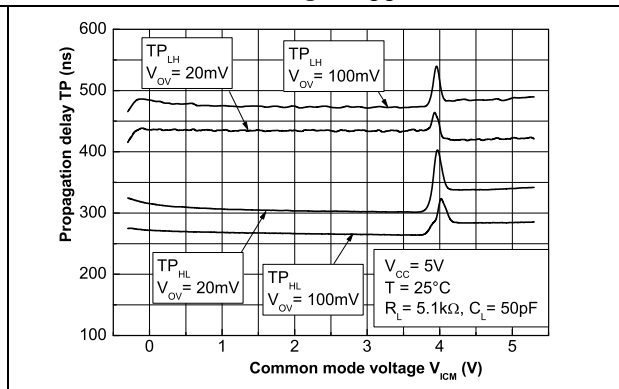

Figure 24. Propagation delay versus time with negative transition

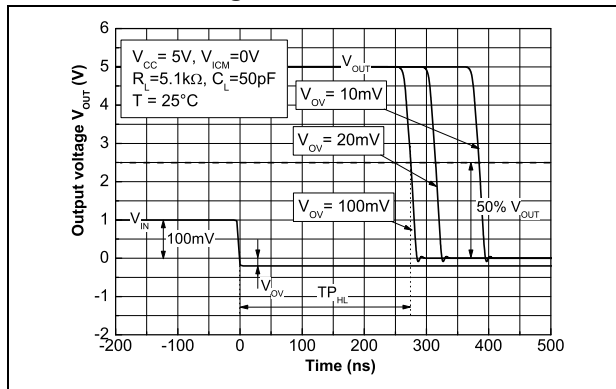
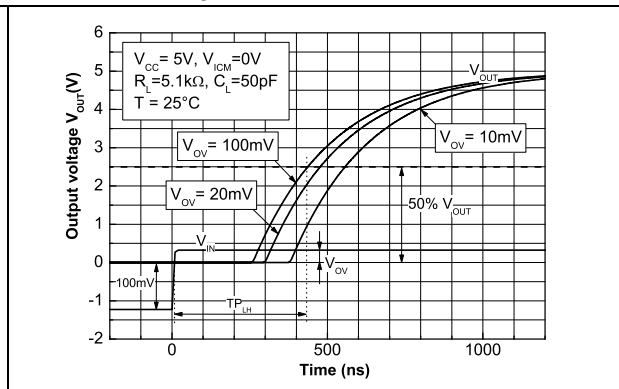

Figure 25. Propagation delay versus time with positive transition



4 Package information

In order to meet environmental requirements, ST offers these devices in different grades of ECOPACK[®] packages, depending on their level of environmental compliance. ECOPACK[®] specifications, grade definitions and product status are available at: www.st.com. ECOPACK[®] is an ST trademark.

4.1 SOT23-5 package information

Figure 26. SOT23-5 package mechanical drawing

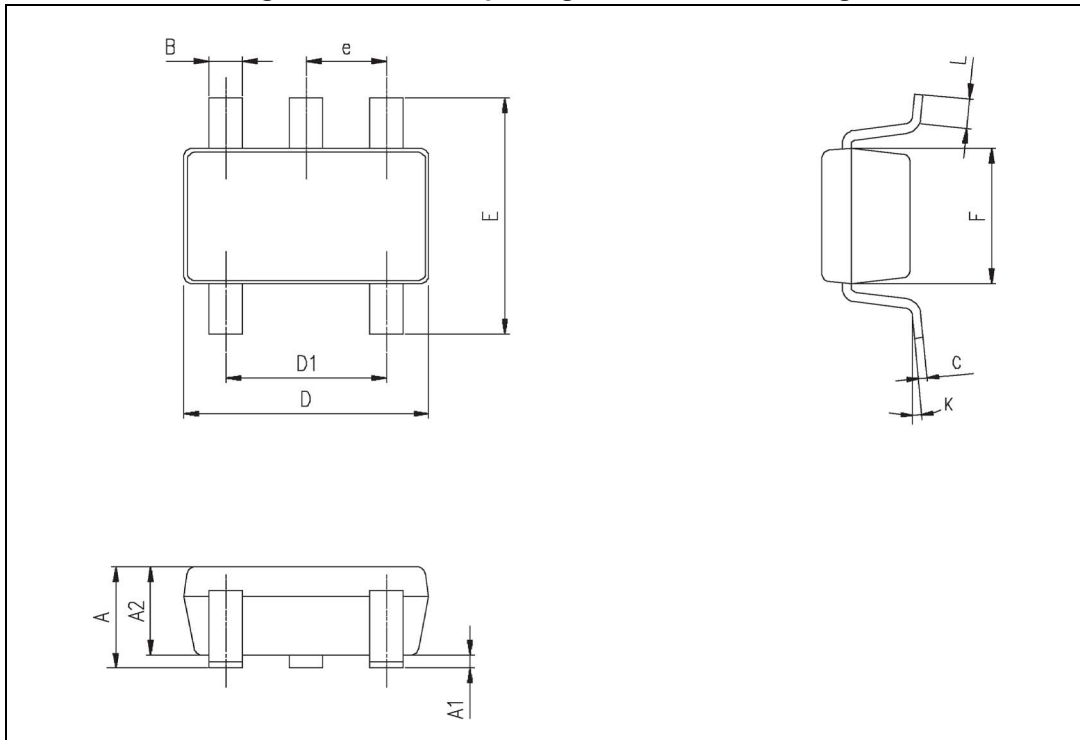

Table 6. SOT23-5 package mechanical data

Ref.	Dimensions					
	Millimeters			Inches ⁽¹⁾		
	Min.	Typ.	Max.	Min.	Typ.	Max.
A	0.90	1.20	1.45	0.035	0.047	0.057
A1			0.15			0.006
A2	0.90	1.05	1.30	0.035	0.041	0.051
B	0.35	0.40	0.50	0.013	0.015	0.019
C	0.09	0.15	0.20	0.003	0.006	0.008
D	2.80	2.90	3.00	0.110	0.114	0.118
D1		1.90			0.075	
e		0.95			0.037	
E	2.60	2.80	3.00	0.102	0.110	0.118
F	1.50	1.60	1.75	0.059	0.063	0.069
L	0.10	0.35	0.60	0.004	0.013	0.023
K	0°		10°	0°		10°

1. Values in inches are rounded to three decimal digits.

4.2 SC70-5 (SOT323-5) package information

Figure 27. SC70-5 (SOT323-5) package mechanical drawing

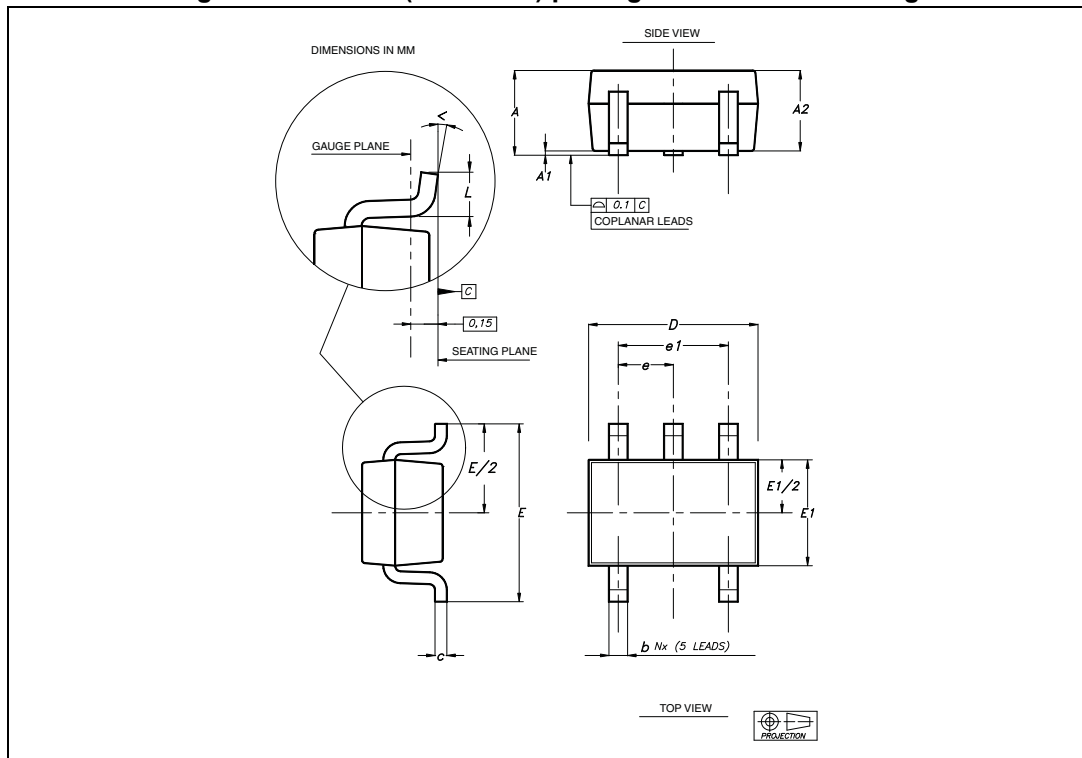

Table 7. SC70-5 (or SOT323-5) package mechanical data

Ref	Dimensions					
	Millimeters			Inches ⁽¹⁾		
	Min	Typ	Max	Min	Typ	Max
A	0.80		1.10	0.315		0.043
A1			0.10			0.004
A2	0.80	0.90	1.00	0.315	0.035	0.039
b	0.15		0.30	0.006		0.012
c	0.10		0.22	0.004		0.009
D	1.80	2.00	2.20	0.071	0.079	0.087
E	1.80	2.10	2.40	0.071	0.083	0.094
E1	1.15	1.25	1.35	0.045	0.049	0.053
e		0.65			0.025	
e1		1.30			0.051	
L	0.26	0.36	0.46	0.010	0.014	0.018
α	0°		8°	0°		8°

1. Values in inches are rounded to three decimal digits.

4.3 DFN6 1.2x1.3 package information

Figure 28. DFN6 1.2x1.3 package mechanical drawing

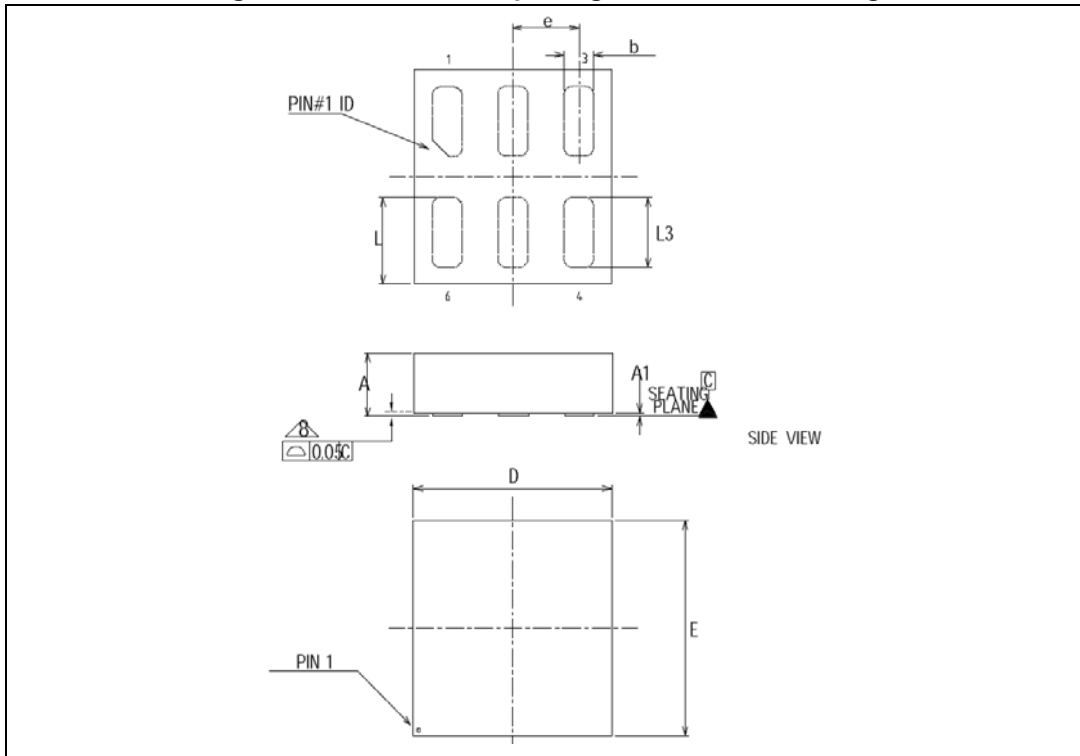

Table 8. DFN6 1.2x1.3 package mechanical data

Ref	Dimensions					
	Millimeters			Inches ⁽¹⁾		
	Min	Typ	Max	Min	Typ	Max
A	0.45	0.50	0.55	0.018	0.020	0.022
A1	0.00	0.02	0.05	0.000	0.001	0.002
b	0.15	0.18	0.25	0.006	0.007	0.002
c		0.05			0.002	
D		1.20			0.047	
E		1.30			0.051	
e		0.4			0.016	
L	0.475	0.525	0.575	0.019	0.021	0.023
L3	0.375	0.425	0.475	0.015	0.017	0.019

1. Values in inches are rounded to three decimal digits.

4.4 DFN8 2x2 package information

Figure 29. DFN8 2x2 package mechanical drawing

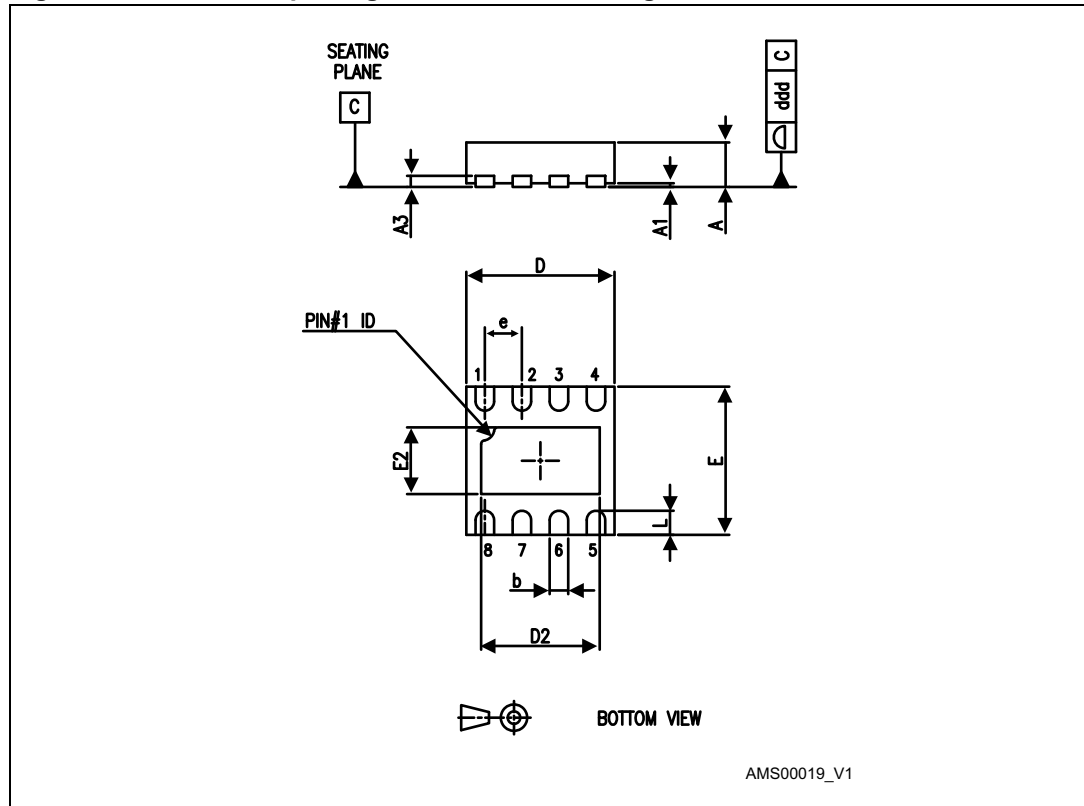
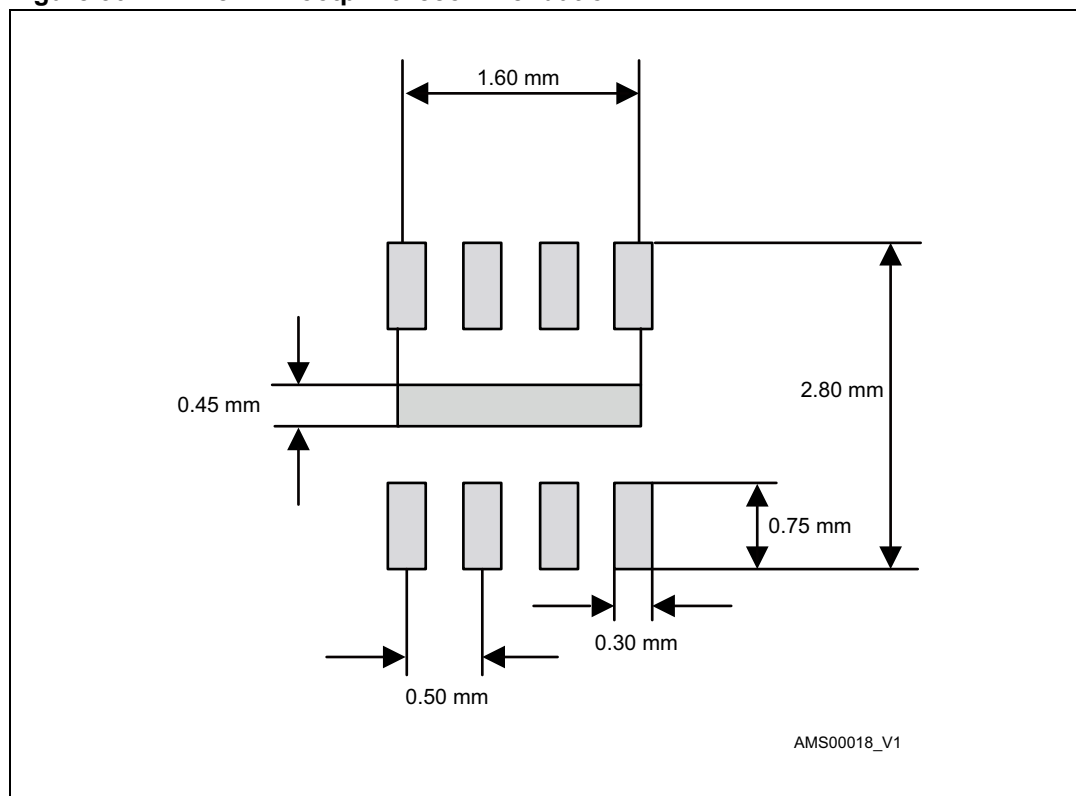

Table 9. DFN8 2x2x0.6 mm package mechanical data (pitch 0.5 mm)

Ref.	Dimensions					
	Millimeters			Inches		
	Min.	Typ.	Max.	Min.	Typ.	Max.
A	0.51	0.55	0.60	0.020	0.022	0.024
A1			0.05			0.002
A3		0.15			0.006	
b	0.18	0.25	0.30	0.007	0.010	0.012
D	1.85	2.00	2.15	0.073	0.079	0.085
D2	1.45	1.60	1.70	0.057	0.063	0.067
E	1.85	2.00	2.15	0.073	0.079	0.085
E2	0.75	0.90	1.00	0.030	0.035	0.039
e		0.50			0.020	
L			0.425			0.017
ddd			0.08			0.003

Figure 30. DFN8 2x2 footprint recommendation



4.5 SO8 package information

Figure 31. SO8 package mechanical drawing

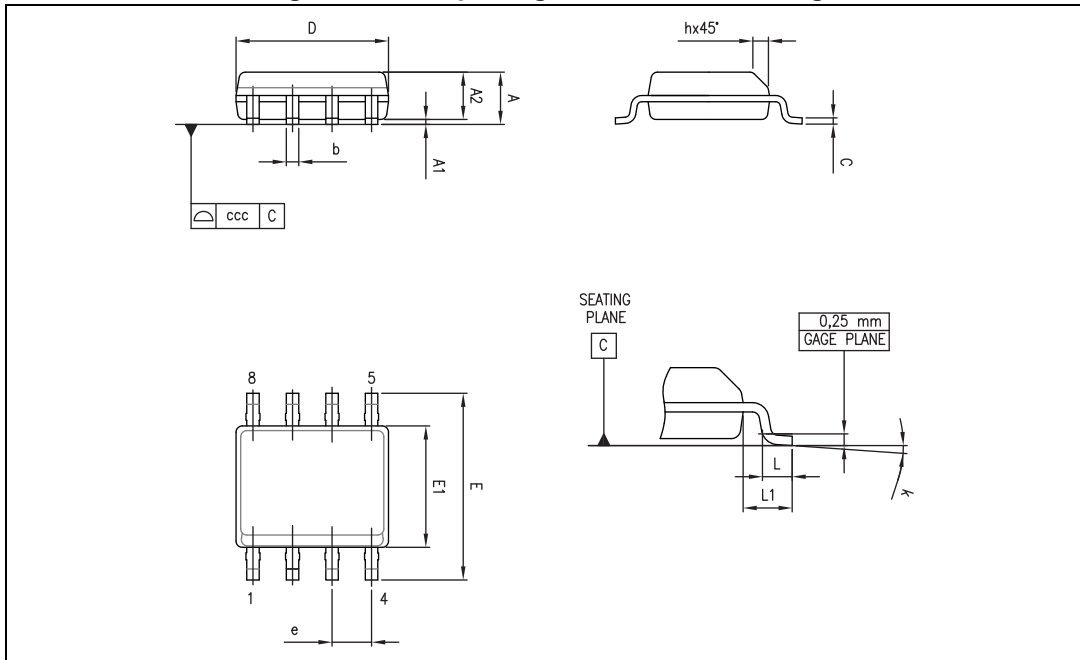

Table 10. SO8 package mechanical data

Ref.	Dimensions					
	Millimeters			Inches ⁽¹⁾		
	Min.	Typ.	Max.	Min.	Typ.	Max.
A			1.75			0.069
A1	0.10		0.25	0.004		0.010
A2	1.25			0.049		
b	0.28		0.48	0.011		0.019
c	0.17		0.23	0.007		0.010
D	4.80	4.90	5.00	0.189	0.193	0.197
E	5.80	6.00	6.20	0.228	0.236	0.244
E1	3.80	3.90	4.00	0.150	0.154	0.157
e		1.27			0.050	
h	0.25		0.50	0.010		0.020
L	0.40		1.27	0.016		0.050
L1		1.04			0.040	
k	0		8°	1°		8°
ccc			0.10			0.004

1. Values in inches are rounded to three decimal digits.

4.6 MiniSO8 package information

Figure 32. MiniSO8 package mechanical drawing

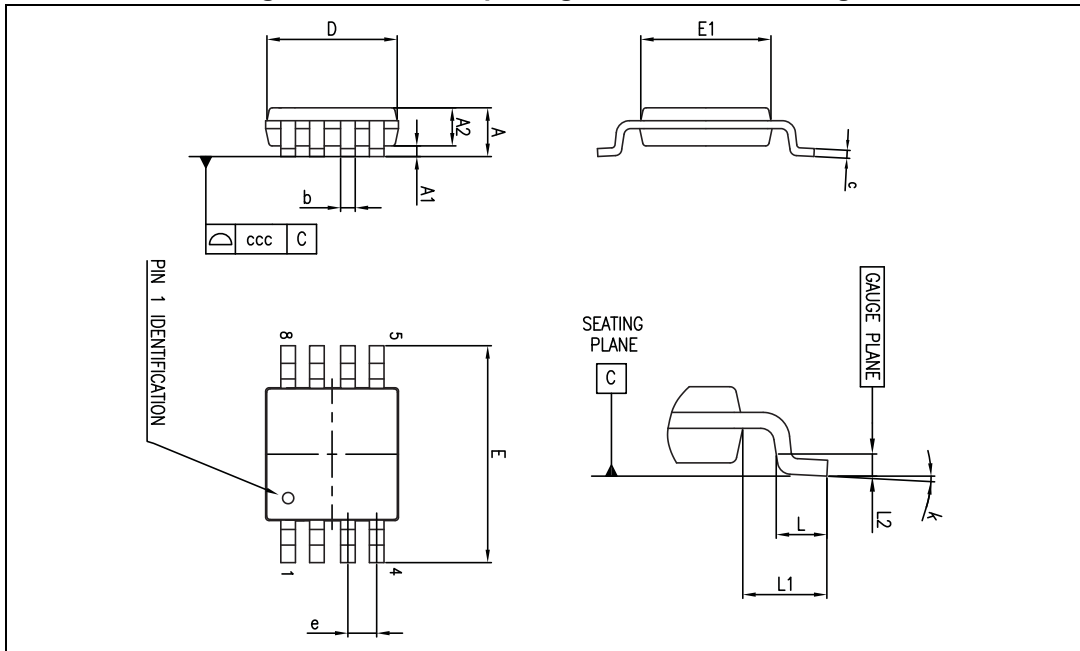

Table 11. MiniSO8 package mechanical data

Ref.	Dimensions					
	Millimeters			Inches ⁽¹⁾		
	Min.	Typ.	Max.	Min.	Typ.	Max.
A			1.1			0.043
A1	0		0.15	0		0.006
A2	0.75	0.85	0.95	0.030	0.033	0.037
b	0.22		0.40	0.009		0.016
c	0.08		0.23	0.003		0.009
D	2.80	3.00	3.20	0.11	0.118	0.126
E	4.65	4.90	5.15	0.183	0.193	0.203
E1	2.80	3.00	3.10	0.11	0.118	0.122
e		0.65			0.026	
L	0.40	0.60	0.80	0.016	0.024	0.031
L1		0.95			0.037	
L2		0.25			0.010	
k	0°		8°	0°		8°
ccc			0.10			0.004

1. Values in inches are rounded to three decimal digits.

4.7 QFN16 3x3 package information

Figure 33. QFN16 3 x 3 mm package mechanical drawing

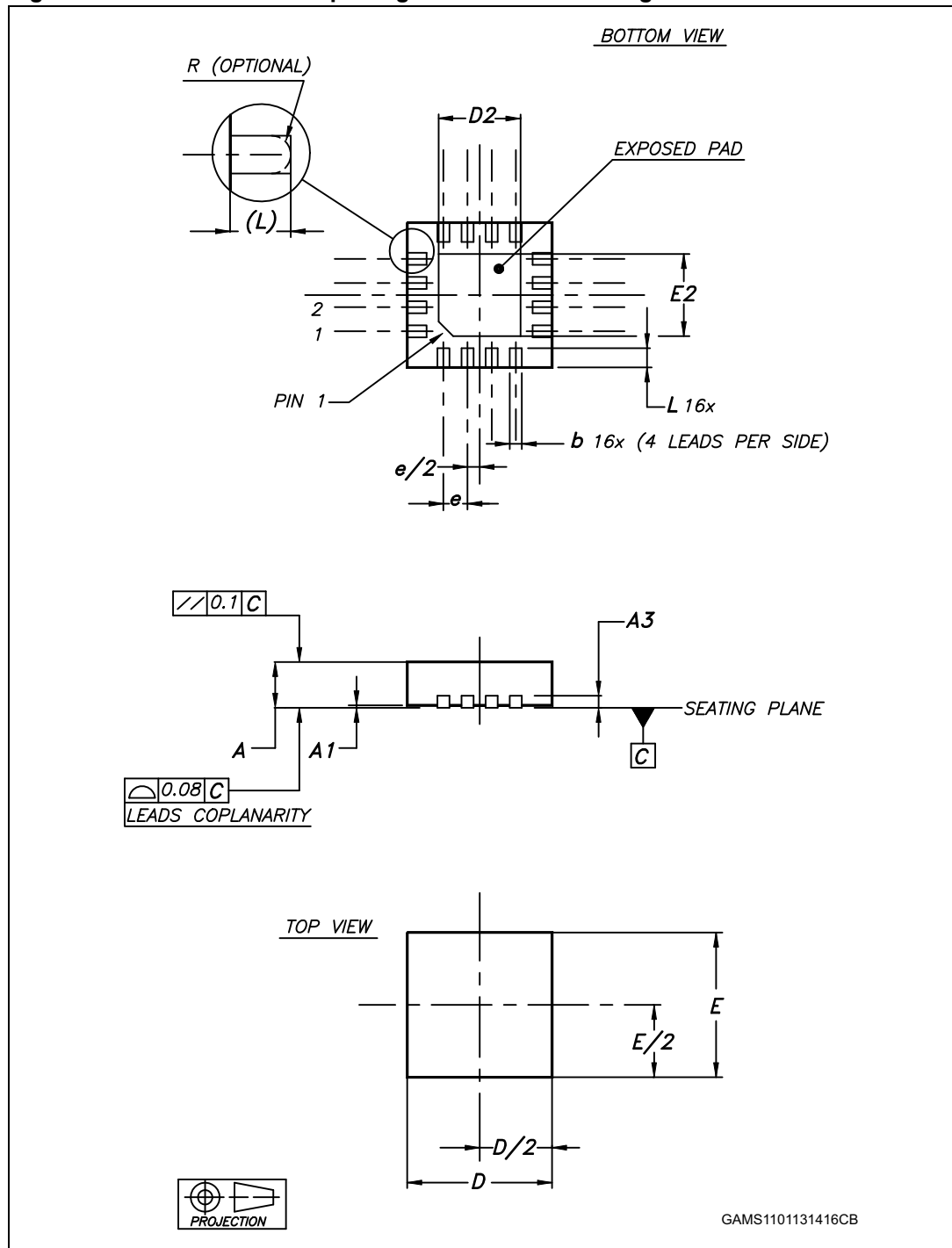
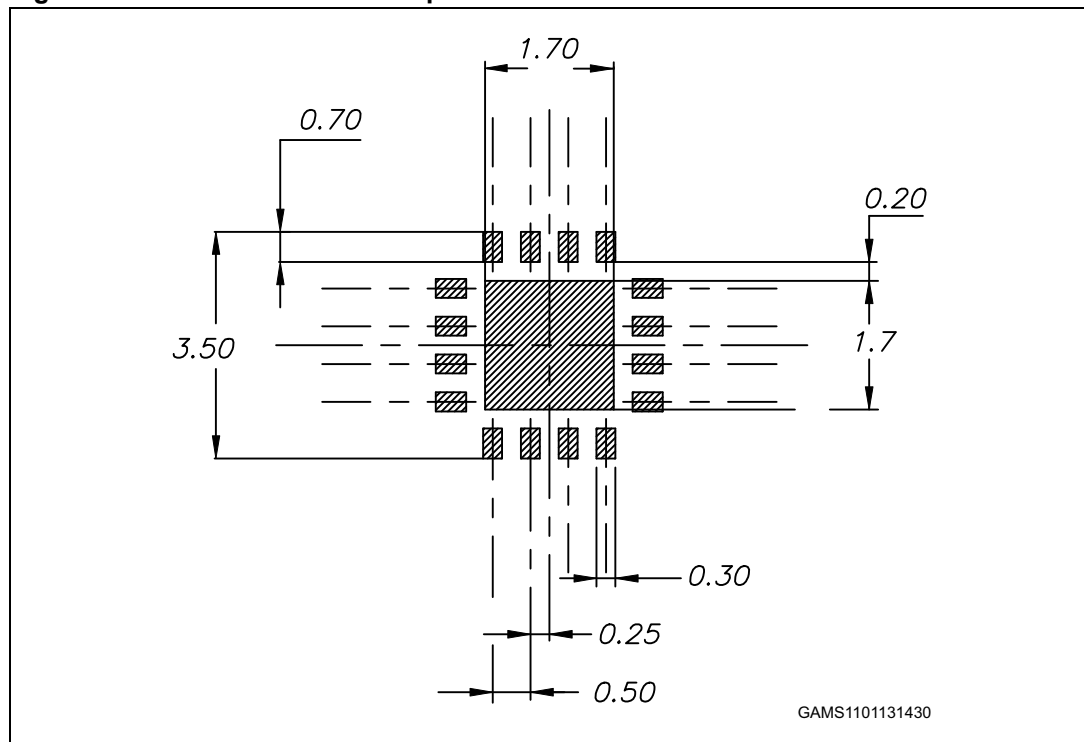

Table 12. QFN16 3 x 3 mm package mechanical data (pitch 0.5 mm)

Ref.	Dimensions					
	Millimeters			Inches		
	Min.	Typ.	Max.	Min.	Typ.	Max.
A	0.80	0.90	1.00	0.031	0.035	0.039
A1	0		0.05	0		0.002
A3		0.20			0.008	
b	0.18		0.30	0.007		0.012
D	2.90	3.00	3.10	0.114	0.118	0.122
D2	1.50		1.80	0.059		0.071
E	2.90	3.00	3.10	0.114	0.118	0.122
E2	1.50		1.80	0.059		0.071
e		0.50			0.020	
L	0.30		0.50	0.012		0.020

Figure 34. QFN16 3 x 3 mm footprint recommendation



4.8 SO14 package information

Figure 35. SO14 package mechanical drawing

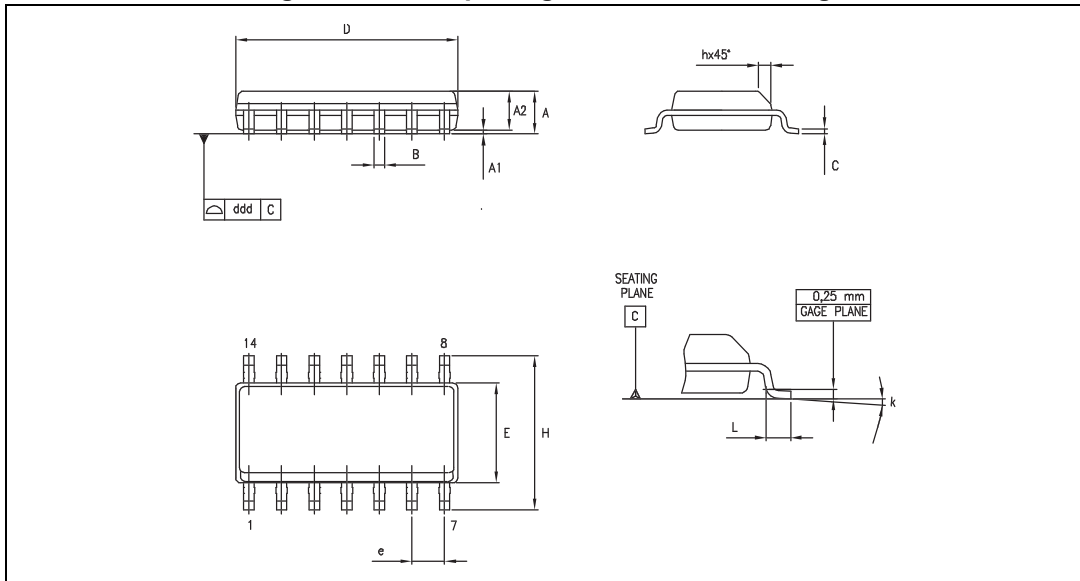

Table 13. SO14 package mechanical data

Dimensions						
Ref.	Millimeters			Inches ⁽¹⁾		
	Min.	Typ.	Max.	Min.	Typ.	Max.
A	1.35		1.75	0.050		0.068
A1	0.10		0.25	0.004		0.009
A2	1.10		1.65	0.040		0.060
B	0.33		0.51	0.010		0.020
C	0.19		0.25	0.007		0.009
D	8.55		8.75	0.330		0.340
E	3.80		4.0	0.150		0.150
e		1.27			0.05	
H	5.80		6.20	0.220		0.240
h	0.25		0.50	0.009		0.020
L	0.40		1.27	0.015		0.050
k	8° (max.)					
ddd			0.10			0.004

1. Values in inches are rounded to three decimal digits.

4.9 TSSOP14 package information

Figure 36. TSSOP14 package mechanical drawing

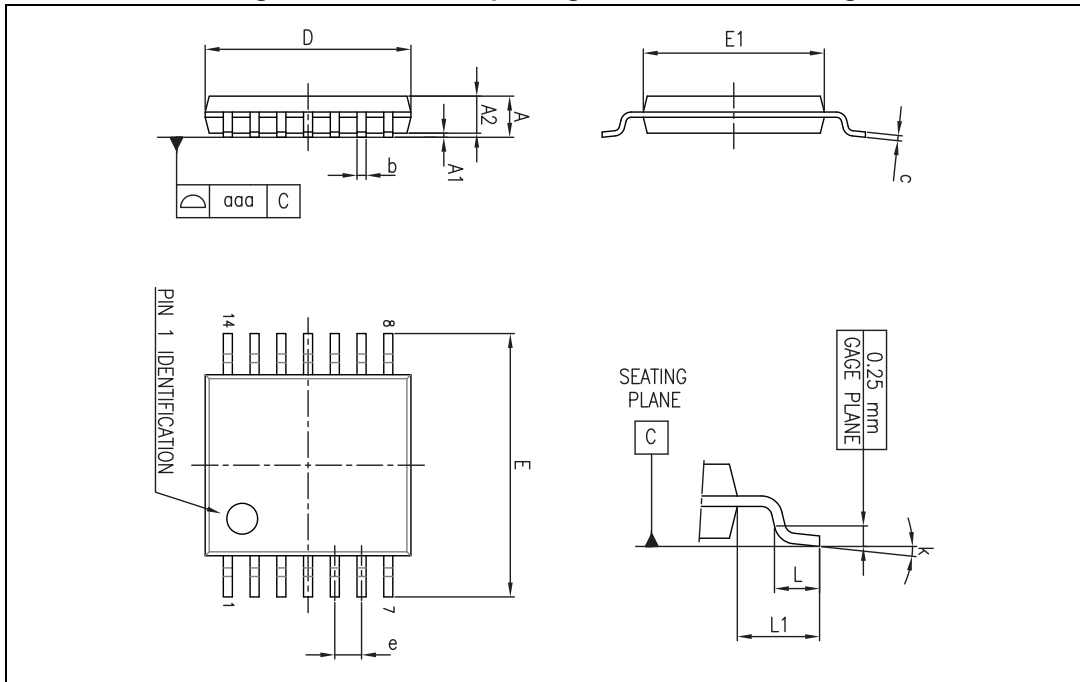

Table 14. TSSOP14 package mechanical data

Ref.	Dimensions					
	Millimeters			Inches ⁽¹⁾		
	Min.	Typ.	Max.	Min.	Typ.	Max.
A			1.20			0.047
A1	0.05		0.15	0.002	0.004	0.006
A2	0.80	1.00	1.05	0.031	0.039	0.041
b	0.19		0.30	0.007		0.012
c	0.09		0.20	0.004		0.0089
D	4.90	5.00	5.10	0.193	0.197	0.201
E	6.20	6.40	6.60	0.244	0.252	0.260
E1	4.30	4.40	4.50	0.169	0.173	0.176
e		0.65			0.0256	
L	0.45	0.60	0.75	0.018	0.024	0.030
L1		1.00			0.039	
k	0°		8°	0°		8°
aaa			0.10			0.004

1. Values in inches are rounded to three decimal digits.

5 Ordering information

Table 15. Order codes

Order code	Temperature range	Package	Packaging	Marking
TS331ILT	-40 °C, +125 °C	SOT23-5	Tape and reel	K506
TS331IYLT ⁽¹⁾				K513
TS331ICT		SC70-5		K55
TS331IQT		DFN6 1.2x1.3		K3
TS332IQ2T		DFN8 2x2		K55
TS332IDT		SO8		332I
TS332IYDT ⁽¹⁾				332IY
TS332IST		MiniSO8		K507
TS334IQ4T		QFN16 3x3		K307
TS334IDT		SO14		334I
TS334IYDT ⁽¹⁾				334IY
TS334IPT		TSSOP14		334I
TS334IYPT ⁽¹⁾				334IY

1. Qualified and characterized according to AEC Q100 and Q003 or equivalent, advanced screening according to AEC Q001 and Q 002 or equivalent.

6 Revision history

Table 16. Document revision history

Date	Revision	Changes
29-Mar-2010	1	Initial release.
01-Dec-2011	2	<ul style="list-style-type: none"> – Added TS332 and TS334 devices. – Added V_{out} parameter in Table 1: Absolute maximum ratings. – Removed note "The magnitude of input and output voltages must never exceed the supply rail ± 0.3 V." from Table 1. – Removed note "All values over the temperature range are guaranteed through correlation and simulation. No production tests have been performed at the temperature range limits." from Table 3, Table 4 and Table 5. – Removed "$V_{icm} = 0$ V" from Test conditions column in Table 3, Table 4 and Table 5. – Modified minimal I_{sink} value in Table 5.
29-Oct-2012	3	<ul style="list-style-type: none"> – Added DFN6 package for TS331 – Modified notes 3, 4, and 5 in Table 1 – Added Automotive grade order codes in Table 15
30-Apr-2013	4	<ul style="list-style-type: none"> – Added DFN8 2x2 and QFN16 3x3 silhouette, pinout, and package information. – Figure 1: updated pinout diagrams; added footnote 2. – Table 1: updated R_{thjc} and R_{thjc} – Table 3, Table 4, Table 5: updated symbol for input offset voltage drift. – Table 15: added order codes TS332IQ2T, TS334IQ4T, and TS334IYDT.

Please Read Carefully:

Information in this document is provided solely in connection with ST products. STMicroelectronics NV and its subsidiaries ("ST") reserve the right to make changes, corrections, modifications or improvements, to this document, and the products and services described herein at any time, without notice.

All ST products are sold pursuant to ST's terms and conditions of sale.

Purchasers are solely responsible for the choice, selection and use of the ST products and services described herein, and ST assumes no liability whatsoever relating to the choice, selection or use of the ST products and services described herein.

No license, express or implied, by estoppel or otherwise, to any intellectual property rights is granted under this document. If any part of this document refers to any third party products or services it shall not be deemed a license grant by ST for the use of such third party products or services, or any intellectual property contained therein or considered as a warranty covering the use in any manner whatsoever of such third party products or services or any intellectual property contained therein.

UNLESS OTHERWISE SET FORTH IN ST'S TERMS AND CONDITIONS OF SALE ST DISCLAIMS ANY EXPRESS OR IMPLIED WARRANTY WITH RESPECT TO THE USE AND/OR SALE OF ST PRODUCTS INCLUDING WITHOUT LIMITATION IMPLIED WARRANTIES OF MERCHANTABILITY, FITNESS FOR A PARTICULAR PURPOSE (AND THEIR EQUIVALENTS UNDER THE LAWS OF ANY JURISDICTION), OR INFRINGEMENT OF ANY PATENT, COPYRIGHT OR OTHER INTELLECTUAL PROPERTY RIGHT.

ST PRODUCTS ARE NOT AUTHORIZED FOR USE IN WEAPONS. NOR ARE ST PRODUCTS DESIGNED OR AUTHORIZED FOR USE IN: (A) SAFETY CRITICAL APPLICATIONS SUCH AS LIFE SUPPORTING, ACTIVE IMPLANTED DEVICES OR SYSTEMS WITH PRODUCT FUNCTIONAL SAFETY REQUIREMENTS; (B) AERONAUTIC APPLICATIONS; (C) AUTOMOTIVE APPLICATIONS OR ENVIRONMENTS, AND/OR (D) AEROSPACE APPLICATIONS OR ENVIRONMENTS. WHERE ST PRODUCTS ARE NOT DESIGNED FOR SUCH USE, THE PURCHASER SHALL USE PRODUCTS AT PURCHASER'S SOLE RISK, EVEN IF ST HAS BEEN INFORMED IN WRITING OF SUCH USAGE, UNLESS A PRODUCT IS EXPRESSLY DESIGNATED BY ST AS BEING INTENDED FOR "AUTOMOTIVE, AUTOMOTIVE SAFETY OR MEDICAL" INDUSTRY DOMAINS ACCORDING TO ST PRODUCT DESIGN SPECIFICATIONS. PRODUCTS FORMALLY ESCC, QML OR JAN QUALIFIED ARE DEEMED SUITABLE FOR USE IN AEROSPACE BY THE CORRESPONDING GOVERNMENTAL AGENCY.

Resale of ST products with provisions different from the statements and/or technical features set forth in this document shall immediately void any warranty granted by ST for the ST product or service described herein and shall not create or extend in any manner whatsoever, any liability of ST.

ST and the ST logo are trademarks or registered trademarks of ST in various countries.

Information in this document supersedes and replaces all information previously supplied.

The ST logo is a registered trademark of STMicroelectronics. All other names are the property of their respective owners.

© 2013 STMicroelectronics - All rights reserved

STMicroelectronics group of companies

Australia - Belgium - Brazil - Canada - China - Czech Republic - Finland - France - Germany - Hong Kong - India - Israel - Italy - Japan - Malaysia - Malta - Morocco - Philippines - Singapore - Spain - Sweden - Switzerland - United Kingdom - United States of America

www.st.com



Mouser Electronics

Authorized Distributor

Click to View Pricing, Inventory, Delivery & Lifecycle Information:

STMicroelectronics:

[TS331ICT](#) [TS331ILT](#) [TS332IDT](#) [TS332IST](#) [TS334IDT](#) [TS334IPT](#) [TS331IQT](#) [TS334IYPT](#) [TS331IYLT](#) [TS332IYDT](#)
[TS334IYDT](#) [TS332IQ2T](#)