

キャビティ&金型番号
CAV&MOLD No

トレードマーク
TRADE MARK

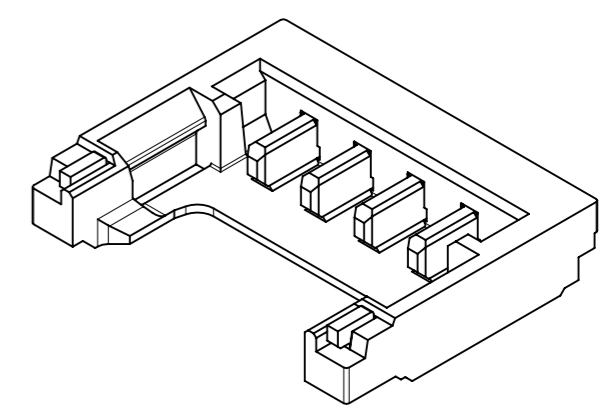
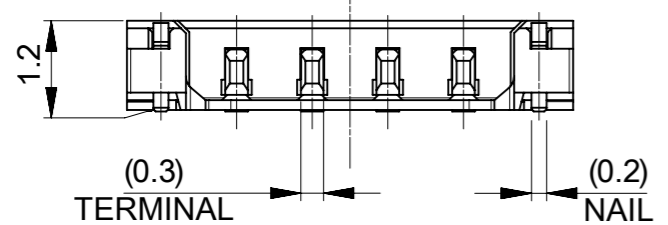
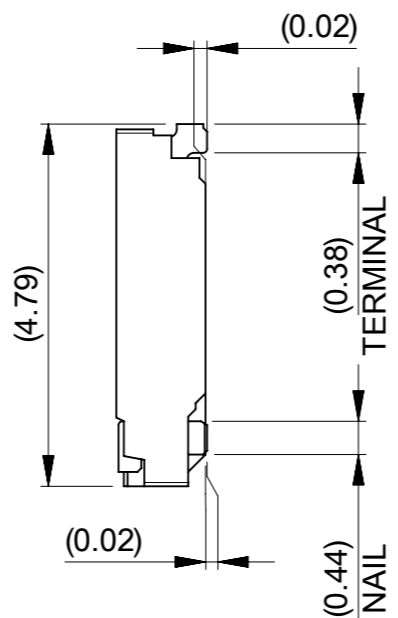
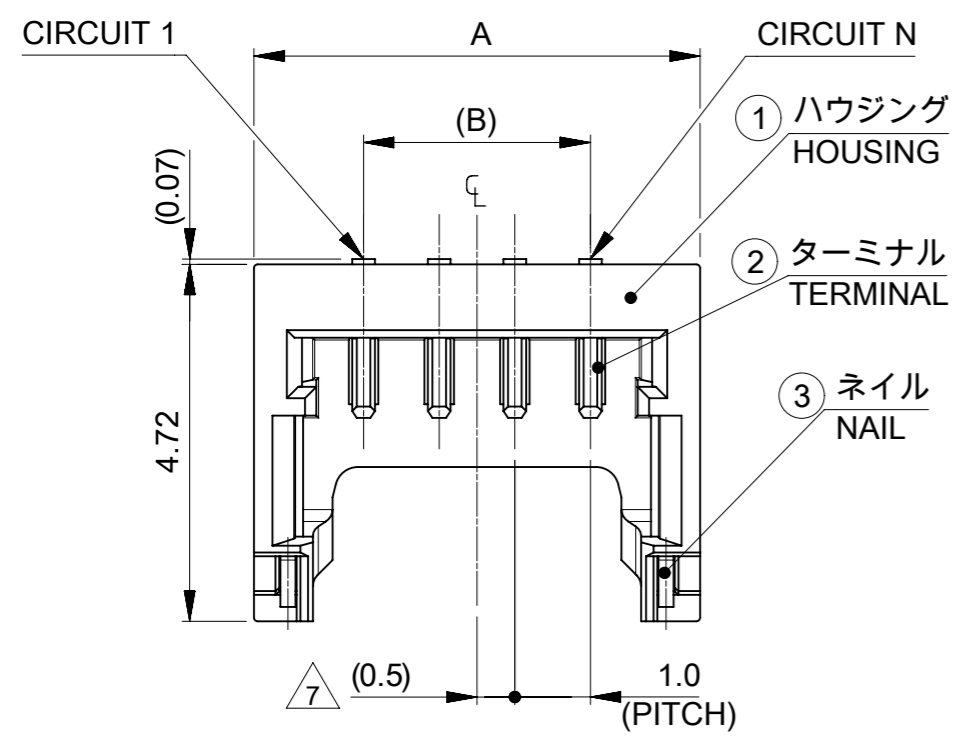

注記
NOTES

- ① 材料および仕上げ(めっき仕様)
MATERIAL AND FINISHES: SEE TABLE 1
- 2. 製品仕様書 : 2121320000-PS/PS /000
PRODUCT SPECIFICATION: 2121320000-PS/PS/000
- 3. 梱包形態 SHEET 3 参照
PACKAGING INFORMATION : SEE SHEET 3
- 4. 嵌合相手 : 212132シリーズ
MATE WITH:212132 SERIES
- 5. アプリケーション仕様書(コネクタ取扱い説明書) : 2166940000-AS/PS/000
APPLICATION SPECIFICATION(CONNECTOR MANUAL) : 2166940000-AS/PS/000
- 6. 端子テール部及びネイルの平坦度:0.1 MAX.
TAIL AND NAIL COPLANARITY TO BE 0.1 MAX.
- ⑦ 極数 = 偶数に適用
APPLY FOR CIRCUIT SIZE = EVEN

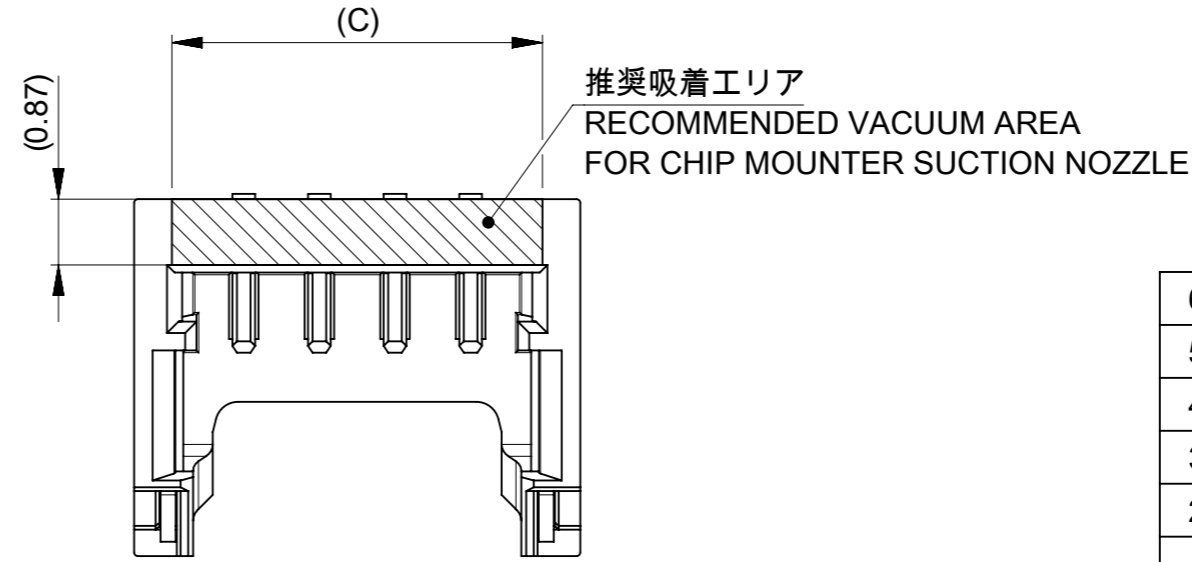

① TABLE 1

番号 NO.	部品 PART	材質 MATERIAL	
①	ハウジング HOUSING	ポリアミド(PA)ガラス入り, UL94V-0, 色 : 黒 POLYAMIDE(PA) GLASS FILLED, UL94V-0, COLOR : BLACK	
②	ターミナル TERMINAL	銅合金 COPPER ALLOY	
		下地めっき UNDER PLATING	ニッケルめっき(下地) : 1.0 micro-meters MIN NICKEL (UNDER PLATING)
		接点部 CONTACT	金めっき : 0.1 micro-meters MIN GOLD PLATING
③	ネイル NAIL	黄銅 BRASS	
		下地めっき UNDER PLATING	ニッケルめっき(下地) : 1.0 micro-meters MIN NICKEL (UNDER PLATING)
		めっき PLATING	錫めっき : 1.0 micro-meters MIN MATTE TIN PLATING
DOCUMENT STATUS	P1	RELEASE DATE	2020/09/17 06:07:18

6.9	5	7.9	6
5.9	4	6.9	5
4.9	3	5.9	4
3.9	2	4.9	3
2.9	1	3.9	2
C	B	A	極数 CIRCUIT SIZE

THIS DRAWING CONTAINS INFORMATION THAT IS PROPRIETARY TO MOLEX ELECTRONIC TECHNOLOGIES, LLC AND SHOULD NOT BE USED WITHOUT WRITTEN PERMISSION		CURRENT REV DESC:		molex	
DIMENSION UNITS	SCALE	EC NO: 643659			
mm	NTS	DRWN: SNAKAMURA08 2019/03/18		PICO-EZMATE PLUS 1.0 W/B PLUG ASSEMBLY FOR GENERAL	
GENERAL TOLERANCES (UNLESS SPECIFIED)		CHK'D: SAKIYAMA 2020/09/17			
ANGULAR TOL	± 3.0 °	APPR: KOMURAKAMI 2020/09/17		PRODUCT CUSTOMER DRAWING	
4 PLACES	± 0.2	INITIAL REVISION:			
3 PLACES	± 0.2	DRWN: SNAKAMURA08 2019/03/18		DOCUMENT NUMBER 2121340000-SD	
2 PLACES	± 0.2	APPR: KOMURAKAMI 2020/09/17			
1 PLACE	± 0.2	DRAFT WHERE APPLICABLE MUST REMAIN WITHIN DIMENSIONS		DOC TYPE DOC PART REVISION PSD 000 A	
0 PLACES	± 0.2	THIRD ANGLE PROJECTION			
DRAWING		SERIES	MATERIAL NUMBER	CUSTOMER	
A3-SIZE		212134	SEE SHEET 3	GENERAL	
SHEET NUMBER		1 OF 3			

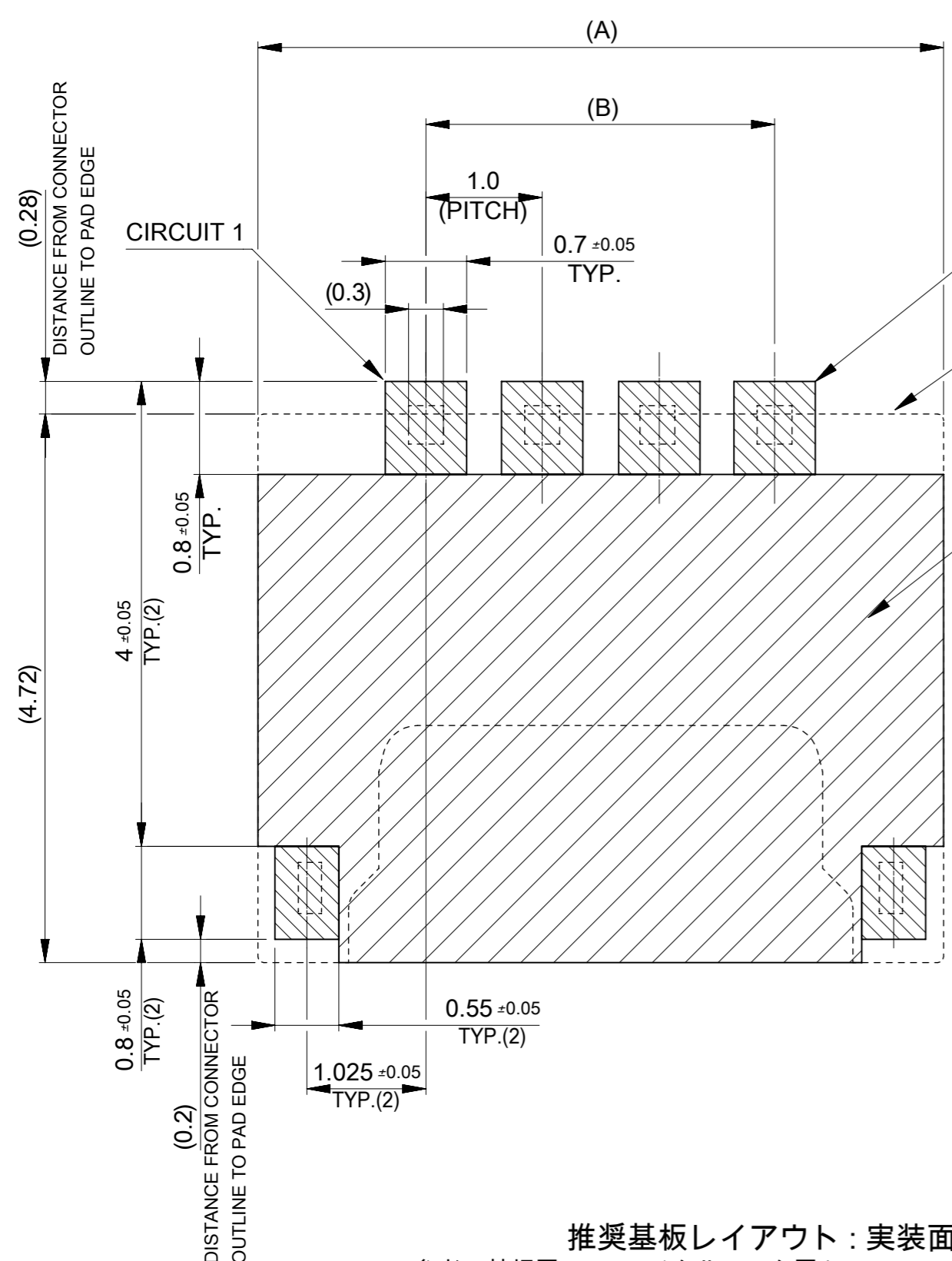

CIRCUIT 1

CIRCUIT N

製品輪郭線
CONNECTOR OUTLINE

パターンおよびはんだ禁止エリア
RESTRICTED AREA
NO PCB COMPONENTS ALLOWED

嵌合相手 : 212132 シリーズ
MATE WITH 212132 SERIES

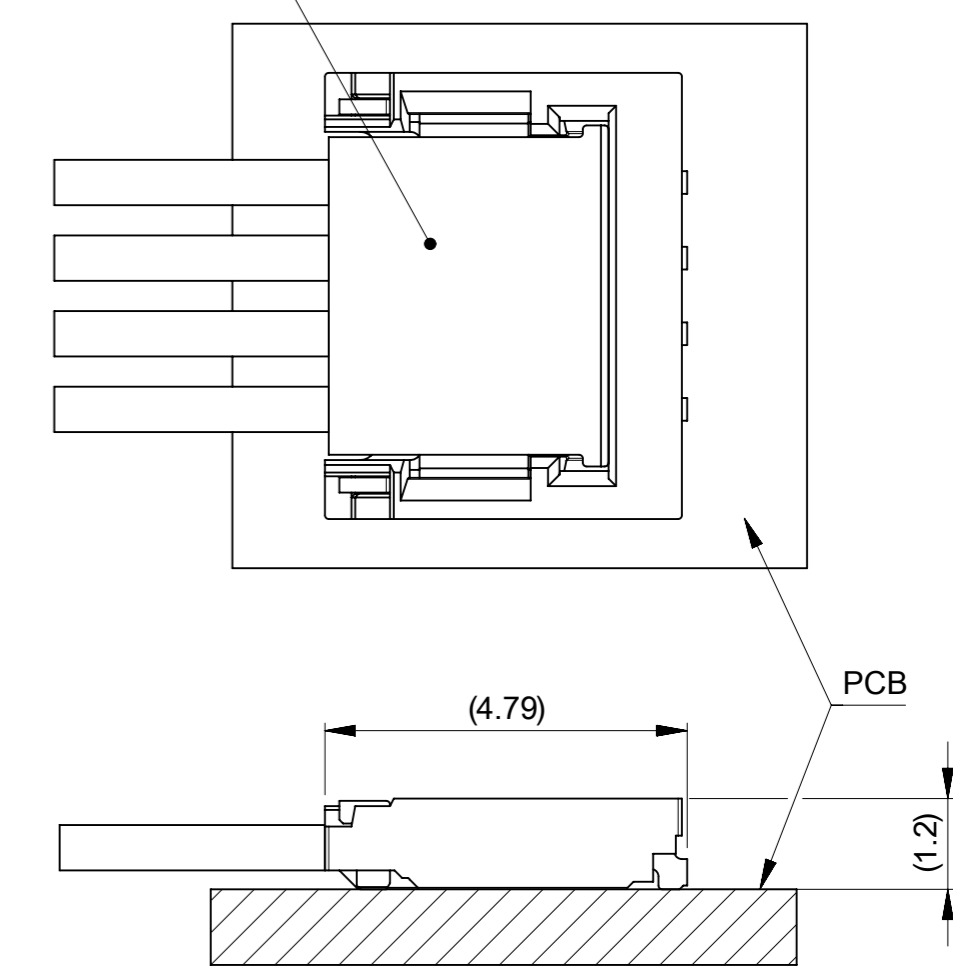

嵌合図
MATED CONNECTORS

推奨基板レイアウト : 実装面側
(参考 : 基板厚1.0mm, メタルマスク厚さ0.1mm, マスク開口率100%)
POLARIZED RECOMMENDED PCB LAYOUT : COMPONENT SIDE
(REFERENCE: PCB THICKNESS 1.0mm, STENCIL THICKNESS 0.1mm, APERTURE RATIO 100%)

THIS DRAWING CONTAINS INFORMATION THAT IS PROPRIETARY TO MOLEX ELECTRONIC TECHNOLOGIES, LLC AND SHOULD NOT BE USED WITHOUT WRITTEN PERMISSION															
DIMENSION UNITS		SCALE		CURRENT REV DESC:											
mm		NTS													
GENERAL TOLERANCES (UNLESS SPECIFIED)				molex PICO-EZMATE PLUS 1.0 W/B PLUG ASSEMBLY FOR GENERAL PRODUCT CUSTOMER DRAWING											
ANGULAR TOL ± 3.0°															
4 PLACES ± 0.2		EC NO: 643659								2019/03/18		DOCUMENT NUMBER		DOC TYPE DOC PART REVISION	
3 PLACES ± 0.2		DRWN: SNAKAMURA08								2020/09/17		2121340000-SD		PSD 000 A	
2 PLACES ± 0.2		CHK'D: SAKIYAMA								2020/09/17		MATERIAL NUMBER		CUSTOMER	
1 PLACE ± 0.2		APPR: KOMURAKAMI								2020/09/17		SEE SHEET 3		GENERAL	
0 PLACES ± 0.2		INITIAL REVISION:		2019/03/18		SERIES		SHEET NUMBER							
DRAFT WHERE APPLICABLE MUST REMAIN WITHIN DIMENSIONS		THIRD ANGLE PROJECTION		DRAWING		212134		2 OF 3							

引き出し方向
PULL OUT DIRECTION

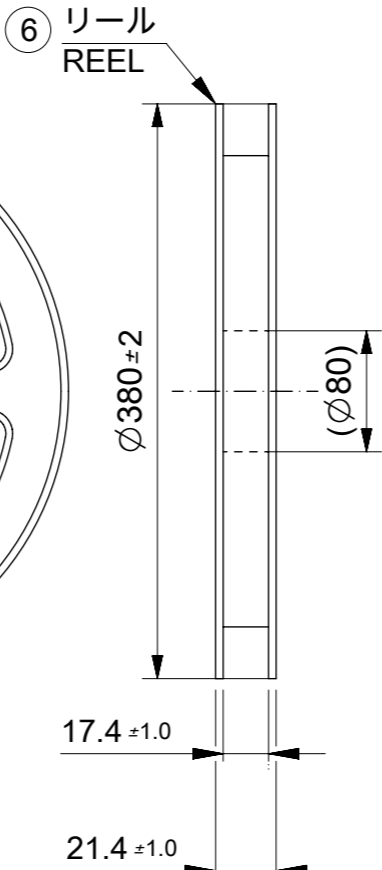
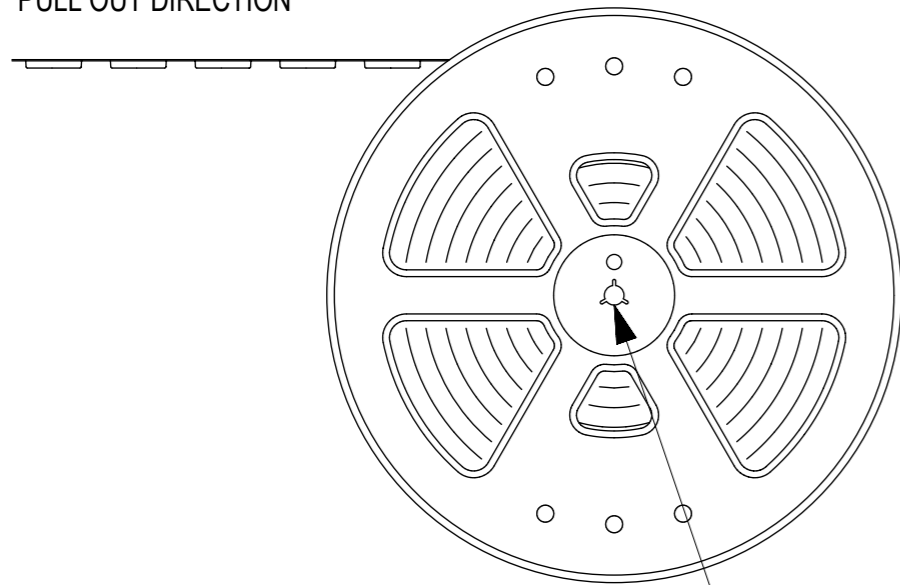

引き出し方向
PULL OUT DIRECTION

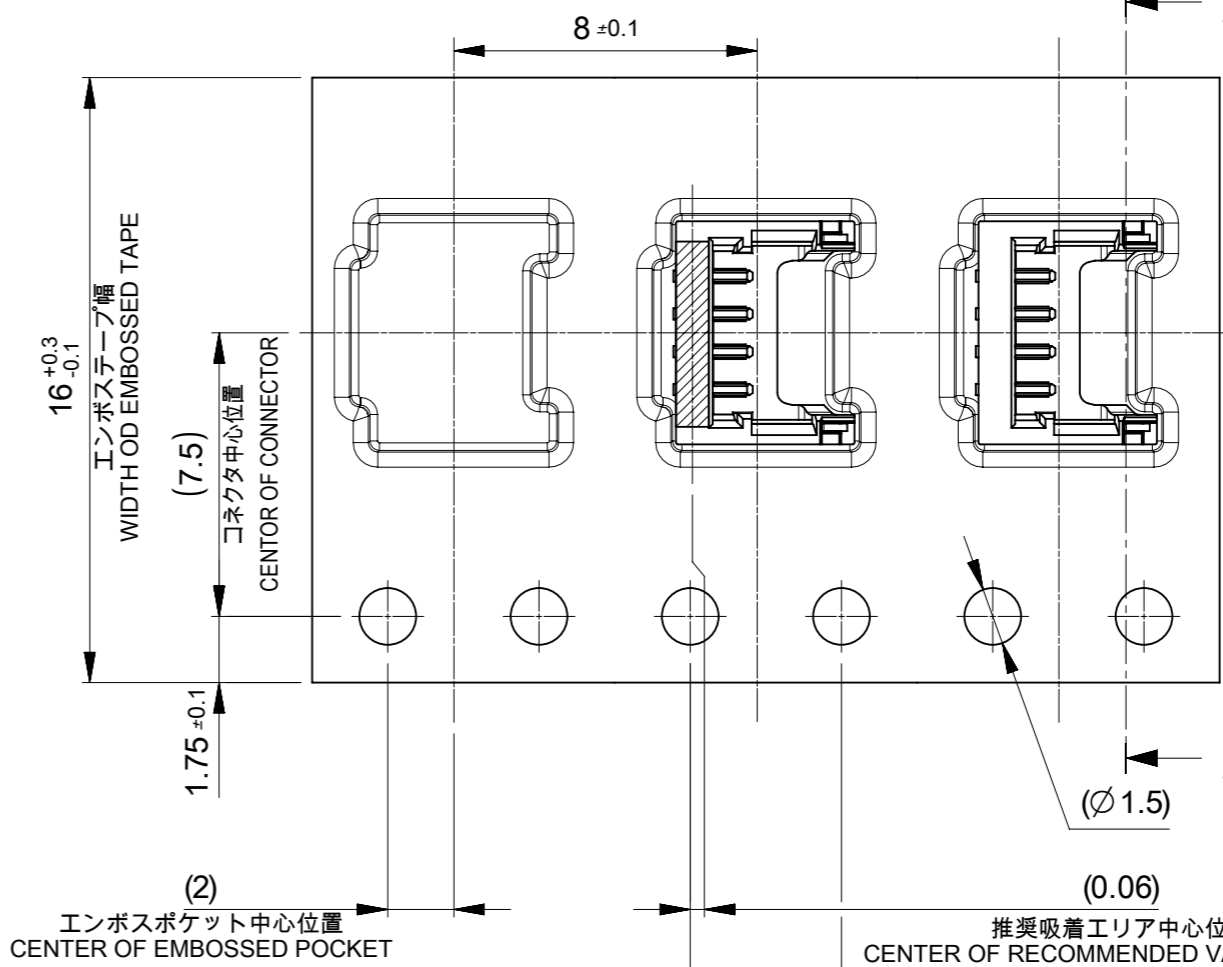

⑤ トップテープ
TOP TAPE

④ エンボステープ
EMBOSSED TAPE

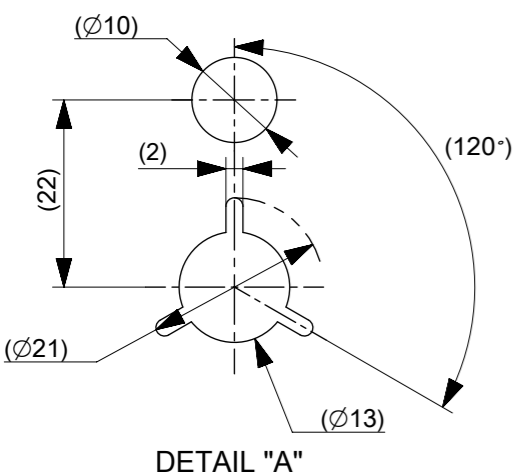
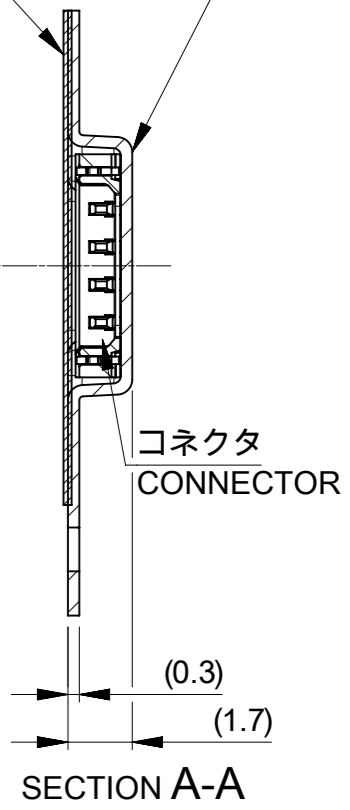

1.75±0.1

エンボスポケット中心位置
CENTER OF EMBOSSED POCKET

推奨吸着エリア中心位置
CENTER OF RECOMMENDED VACUUM AREA

累積ピッチ:40±0.2
ACCUMULATIVE PITCH

NOTES

8. 梱包数量 : 7000個/リール
NUMBER OF CONNECTORS : 7000 PIECES/REEL

9. リードテープ長さ
LEAD TAPE LENGTH

10. トップテープの剥離強度はIEC60286-3に準拠。
TOP TAPE PEELING FORCE IS DEFINED BY IEC60286-3.

11. 梱包仕様書 : 2121349200-SPK/PS/000
PACKAGING SPECIFICATION : 2121349200-SPK/PS/000

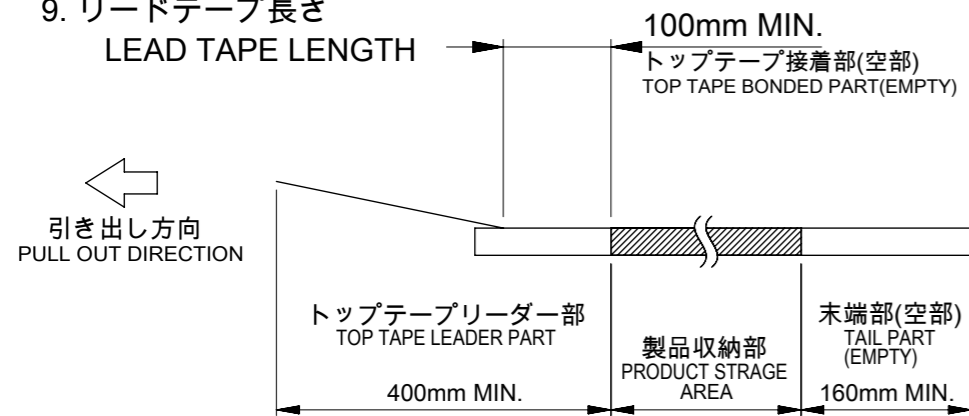

発注番号 ORDER No.	
2121340006	6
2121340005	5
2121340004	4
2121340003	3
2121340002	2
梱包形態 : エンボスリール PACKAGING STYLE : EMBOSSED TAPE AND REEL	極数 CIRCUIT SIZE

番号 NO.	部品 PART	材質 MATERIAL
④	エンボステープ EMBOSSED TAPE	ポリスチレン (PS),その他 POLYSTYRENE(PS), etc
⑤	トップテープ TOP TAPE	ポリエチレン(PE)、その他 POLYETHYLENE(PE), etc
⑥	リール REEL	ポリスチレン(PS) <リサイクル材を含む> POLYSTYRENE(PS) <RECYCLE MATERIAL CONTAINED>

THIS DRAWING CONTAINS INFORMATION THAT IS PROPRIETARY TO MOLEX ELECTRONIC TECHNOLOGIES, LLC AND SHOULD NOT BE USED WITHOUT WRITTEN PERMISSION

DIMENSION UNITS mm	SCALE NTS	CURRENT REV DESC:	molex		
GENERAL TOLERANCES (UNLESS SPECIFIED)					
4 PLACES ± 0.2	3 PLACES ± 0.2	2 PLACES ± 0.2	PICO-EZMATE PLUS 1.0 W/B PLUG ASSEMBLY FOR GENERAL		
1 PLACE ± 0.2	0 PLACES ± 0.2	EC NO: 643659	PRODUCT CUSTOMER DRAWING		
DRAFT WHERE APPLICABLE MUST REMAIN WITHIN DIMENSIONS			DRWN: SNAKAMURA08 2019/03/18	CHK'D: SAKIYAMA 2020/09/17	APPR: KOMURAKAMI 2020/09/17
THIRD ANGLE PROJECTION			INITIAL REVISION:	DOCUMENT NUMBER	DOC TYPE DOC PART REVISION
DRAWING A3-SIZE			DRWN: SNAKAMURA08 2019/03/18	2121340000-SD	PSD 000 A
SERIES 212134			APPR: KOMURAKAMI 2020/09/17	MATERIAL NUMBER SEE TABLE	CUSTOMER GENERAL
SHEET NUMBER 3 OF 3					