

REVISIONS				
REV. SYM.	E.C.O. NUMBER	DESCRIPTION	BY DATE	APP'D DATE
1		ORIGINAL RELEASE	AAM 7-16-99	RRR 7-16-99

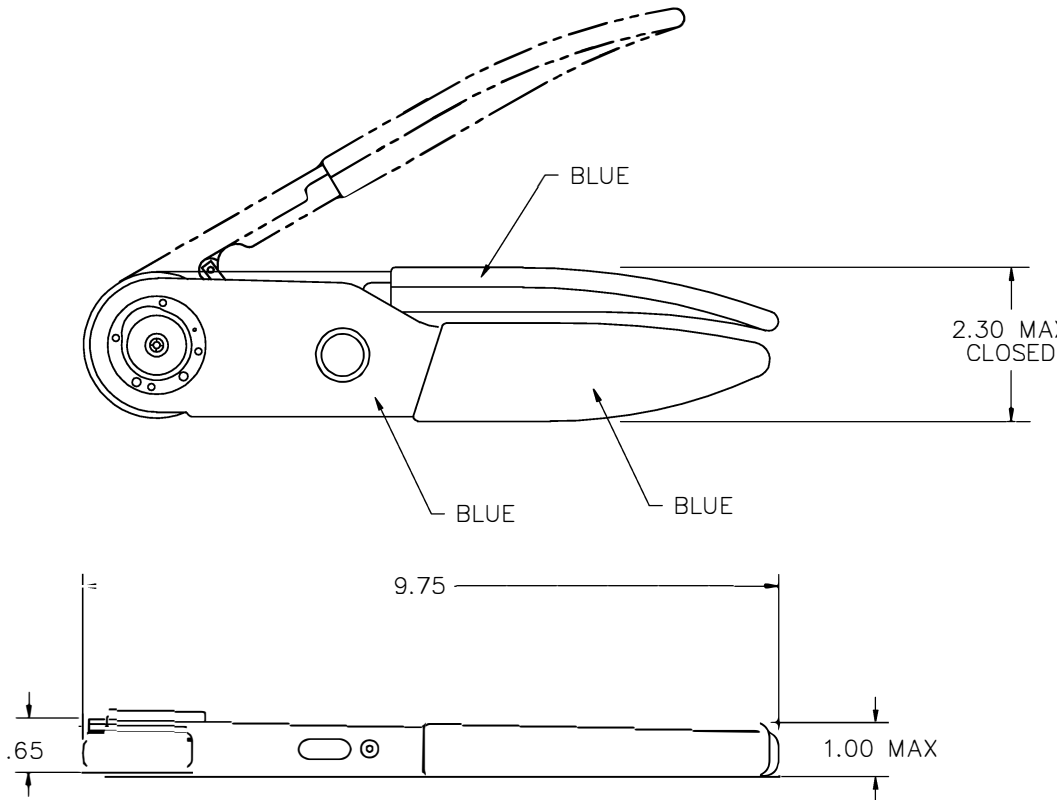

2. USE GAGE P/N G925
1. GAGING DIMENSIONS (FIGURE 1):
GO .042 / NO-GO .046

NOTES:

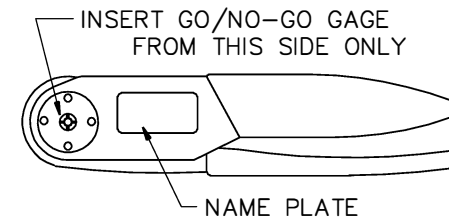

FIGURE 1

UNCONTROLLED DOCUMENT
WILL NOT BE UPDATED

RESTRICTED & CONFIDENTIAL

CONFIDENTIAL PROPERTY OF DANIELS MANUFACTURING CORP. NOT TO BE DISCLOSED TO OTHERS, REPRODUCED OR USED FOR ANY OTHER PURPOSE, EXCEPT AS AUTHORIZED IN WRITING BY DANIELS MANUFACTURING. MUST BE RETURNED TO DANIELS MANUFACTURING CORP. ON COMPLETION OF ORDER OR OTHER PURPOSE FOR WHICH LENT.

DO NOT SCALE DRAWING

ITEM	PART NO.	QTY.	DESCRIPTION/REMARKS
DRN. A. MOO-YOUNG	DATE 7-16-99		DMC DANIELS MANUFACTURING CORP. ORLANDO, FLORIDA CAGE 11851
CHK'D. RRR	DATE 7-16-99		
APP'D.	DATE		TITLE
APP'D.	DATE		ENVELOPE DRAWING CIRCULAR CRIMP TOOL
NOTE: THIS DRAWING IS AN OUTLINE DRAWING OF THE RESPECTIVE DMC PART NUMBER INDICATED. ACTUAL DMC PART NUMBER IS DRAWING NUMBER WITHOUT THE "-ENV" SUFFIX.		WHERE USED: SIZE B SCALE NTS	CAD P/N GS210-ENV SHEET OF
		POSTING	DWG. NO. GS210-ENV REV. 1

Mouser Electronics

Authorized Distributor

Click to View Pricing, Inventory, Delivery & Lifecycle Information:

[Daniels Manufacturing:](#)

[GS210](#)