

### 875 Series Fuse, Lead-free 3.6×10 mm, Slo-Blo® Fuse

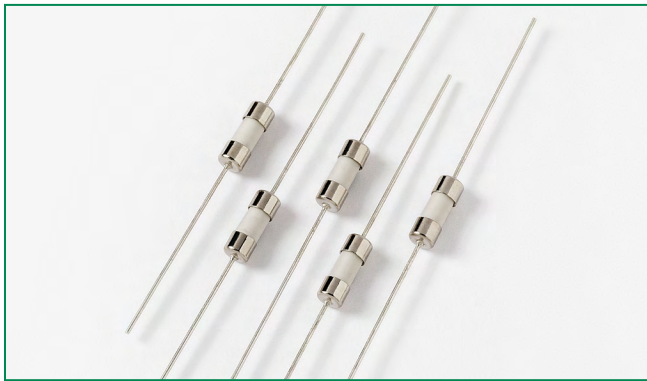

#### Description

Single Pigtail Axial Lead 3.6×10mm, Slo-Blo® Fuse

#### Features

- Designed to UL/CSA 248 Standard
- Single Pigtail Axial Lead format
- Slo-Blo® Fuse, ceramic body fuse in a compact package
- Pb-free and RoHS Compliant
- Available in ratings of 0.10 to 10 Amperes

#### Applications

This space saving fuse is ideally suited for lighting, power supply, and adapter applications.

#### Agency Approvals

Agency	Agency File Number	Ampere Range
	E10480	0.100A - 10 A

#### Additional Information



Datasheet



Resources



Samples

#### Electrical Characteristics

% of Ampere Rating	Opening Time
100%	4 hours, Minimum
200%	60 seconds, Maximum

#### Electrical Characteristics

Amp Code	Ampere Rating (A)	Voltage Rating (V)	Interrupting Rating	Nominal Cold Resistance (Ohms)	Nominal Melting I <sup>2</sup> t (A <sup>2</sup> sec)	Agency Approvals 
.100	0.100	250	50A @ 250 VAC	3.000	0.0023	x
.125	0.125	250		2.060	0.0072	x
.200	0.200	250		0.921	0.0086	x
.250	0.250	250		0.6575	0.038	x
.300	0.300	250		0.435	0.043	x
.400	0.400	250		0.321	0.136	x
.500	0.500	250		0.256	0.288	x
.600	0.600	250		0.151	0.611	x
.800	0.800	250		0.116	0.919	x
001.	1.00	250		0.095	1.503	x
01.5	1.50	250		0.0519	4.33	x
01.6	1.60	250		0.0476	5.08	x
002.	2.00	250		0.02887	8.45	x
02.5	2.50	250		0.02246	17.85	x
003.	3.00	250		0.0171	42.85	x
004.	4.00	250		0.0135	42.45	x
005.	5.00	250		0.00954	60.90	x
006.	6.00	250		0.00891	72.30	x
007.	7.00	250		0.008	106.80	x
008.	8.00	250		0.0077	134.59	x
010.	10.00	250	0.00675	208.00	x	

Notes:  
Cold resistance measured at less than 10% of rated current at 23°C.

### Temperature Re-rating Curve

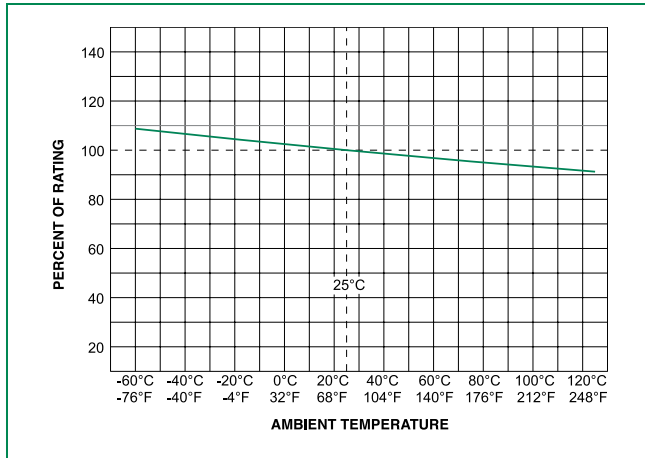

Note:  
 1. Rerating depicted in this curve is in addition to the standard derating of 25% for continuous operation.

### Average Time Current Curves

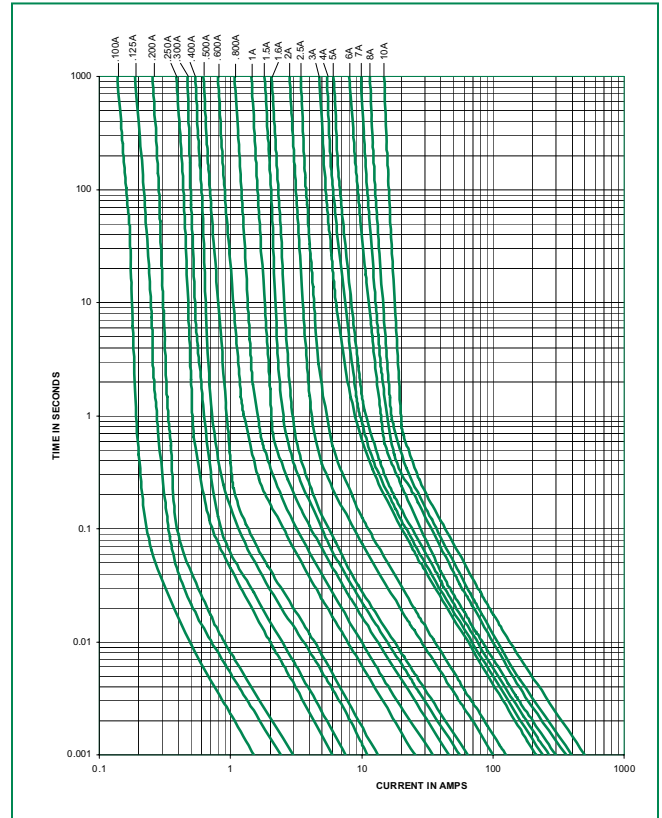

### Soldering Parameters - Wave Soldering

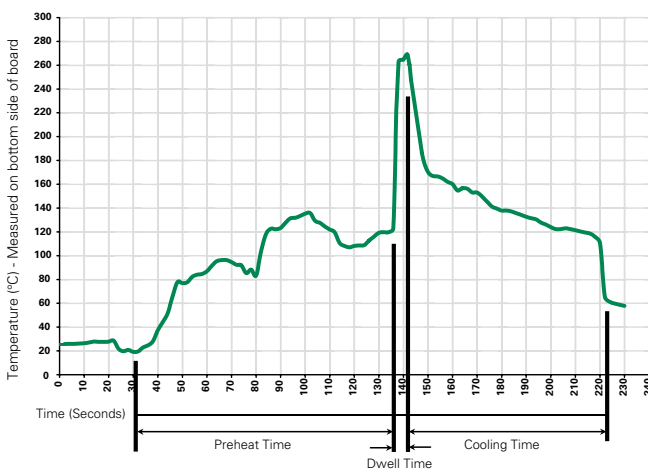

### Recommended Process Parameters:

Wave Parameter	Lead-Free Recommendation
<b>Preheat:</b> (Depends on Flux Activation Temperature) (Typical Industry Recommendation)	
Temperature Minimum:	100°C
Temperature Maximum:	150°C
Preheat Time:	60-180 seconds
<b>Solder Pot Temperature:</b>	260°C Maximum
<b>Solder Dwell Time:</b>	2-5 seconds

### Recommended Hand-Solder Parameters:

Solder Iron Temperature: 350°C +/- 5°C  
 Heating Time: 5 seconds max.

**Note: These devices are not recommended for IR or Convection Reflow process.**

### Product Characteristics

<b>Materials</b>	Body: Ceramic Cap: Nickel Plated Brass Tin Plated Copper
<b>Terminal Strength</b>	MIL-STD-202, Method 211, Test Condition A
<b>Solderability</b>	MIL-STD-202, Method 208
<b>Product Marketing</b>	Body: Brand Logo, Current Rating Characteristic "T", Agency approval marks
<b>Packaging</b>	Bulk (1000 pcs/pkg) Tape & Reel (1000 pcs/reel)

<b>Operating Temperature</b>	-55°C to 125°C
<b>Thermal Shock</b>	MIL-STD-202, Method 107 Test Condition B3 (5 cycles -65°C to +125°C)
<b>Vibration</b>	MIL-STD-202, Method 201 (10-55 Hz)
<b>Humidity</b>	MIL-STD-202, Method 106, High Humidity (90-98%RH), Heat (65°C)
<b>Salt Spray</b>	MIL-STD-202, Method 101, Test Condition B

### Dimensions

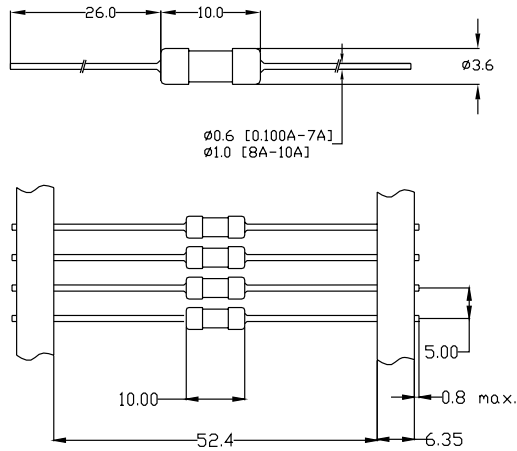

All dimensions in mm

### Part Numbering System

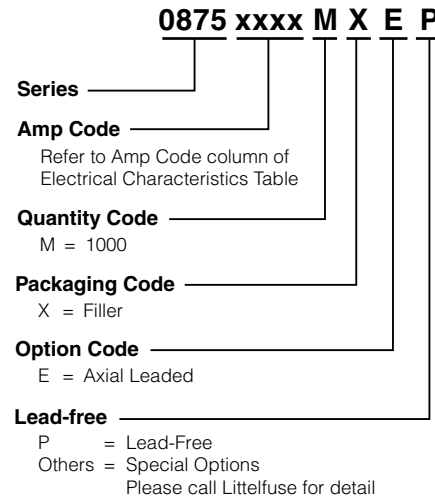

### Packaging

Packaging Option	Packaging Specification	Quantity	Quantity & Packaging Code	Taping Width
<b>875 Series</b>				
Bulk	Bulk	1000	MXE	N/A
Tape and Reel	EIA 296	1000	MRET1	T1 = 52mm (2.062")