

RIVKLE® plus top class steel blind rivet nuts

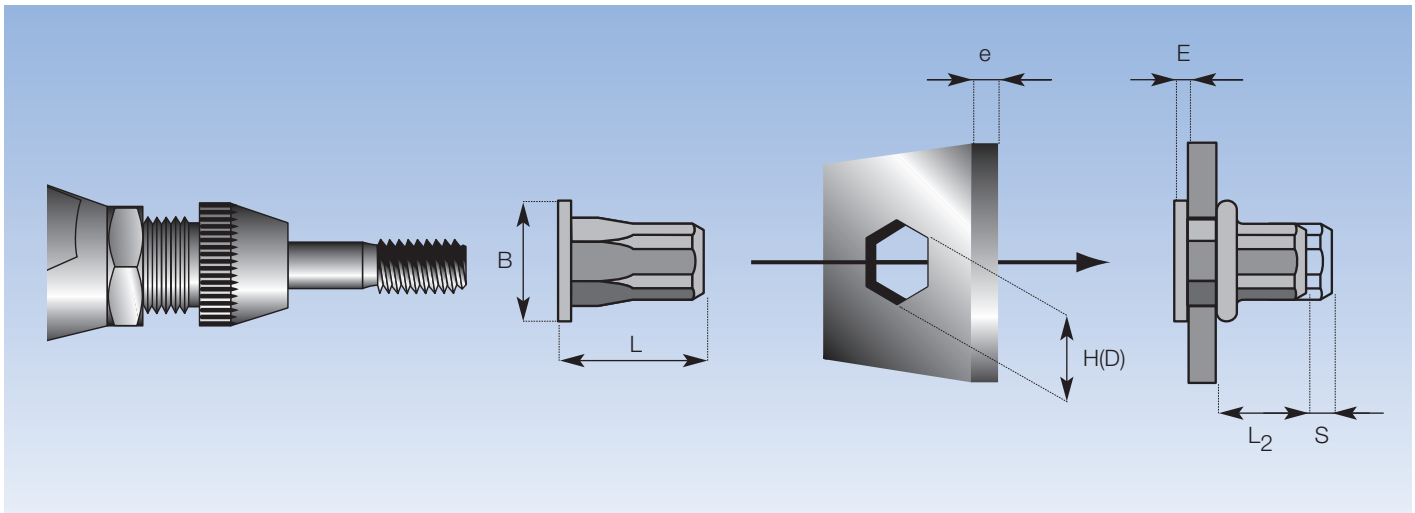

Type	Thread d	Material-thickness e	Hole-round (D) hexagonal (H) Tol. 0+0,1	Ø Head B	Projection after setting E	Setting stroke S	Total length L	Blind side projection after setting L ₂	Product code
B 70 300									
	M4	0.5 – 3	6	9	1	S = 4.5-e	11.3	5.8	2330 704 0230
	M5	0.5 – 3	7	10	1	S = 4.7-e	13	7.3	2330 705 0230
	M6	0.5 – 3	9	13	1.5	S = 5-e	14.5	8	2330 706 0230
	M6	3 – 5.5	9	13	1.5	S = 7.5-e	17.2	8.2	2330 706 0255
	M8	0.5 – 3	11	16	1.5	S = 5.5-e	18	11	2330 708 0230
	M8	3 – 5.5	11	16	1.5	S = 8.1-e	20.7	11.1	2330 708 0255
	M10	0.7 – 3.5	13	19	2	S = 6.1-e	22	13.9	2330 710 0235
B 70 500									
	M4	0.5 – 3	6	9	1	S = 4.5-e	11.3	5.8	2334 104 0230
	M5	0.5 – 3	7	10	1	S = 4.7-e	13	7.3	2334 105 0230
	M6	0.5 – 3	9	13	1.5	S = 5-e	14.5	8	2334 106 0230
	M8	0.5 – 3	11	16	1.5	S = 5.3-e	18	11.2	2334 108 0230
B 71 100									
	M4	0.5 – 3	6	6.7	0.3	S = 4.9-e	11	5.8	3436 704 0230
	M5	0.5 – 3	7	8	0.3	S = 5.3-e	13	7.4	3436 705 0230
	M6	0.5 – 3	9	10	0.4	S = 5.1-e	14	8.5	3436 706 0230
	M8	0.5 – 3	11	12	0.4	S = 6-e	17.5	11.1	3436 708 0230
	M10	0.7 – 3.5	13	14	0.5	S = 6.5-e	21	14	3436 710 0235
B 71 200									
	M4	0.5 – 3	6	7.5	0.3	S = 4.7-e	11	6	3434 104 0230
	M5	0.5 – 3	7	8.7	0.3	S = 5.2-e	13	7.5	3434 105 0230
	M6	0.5 – 3	9	10.9	0.4	S = 5.3-e	14	8.3	3434 106 0230
	M8	0.5 – 3	11	13.3	0.4	S = 5.8-e	17.5	11.3	3434 108 0230

Dimensions in mm

Surface treatment: 8 µ zinc plated + yellow passivated.