

Oberteil-Draufsicht
TOP, REAL OUTSIDE-VIEW

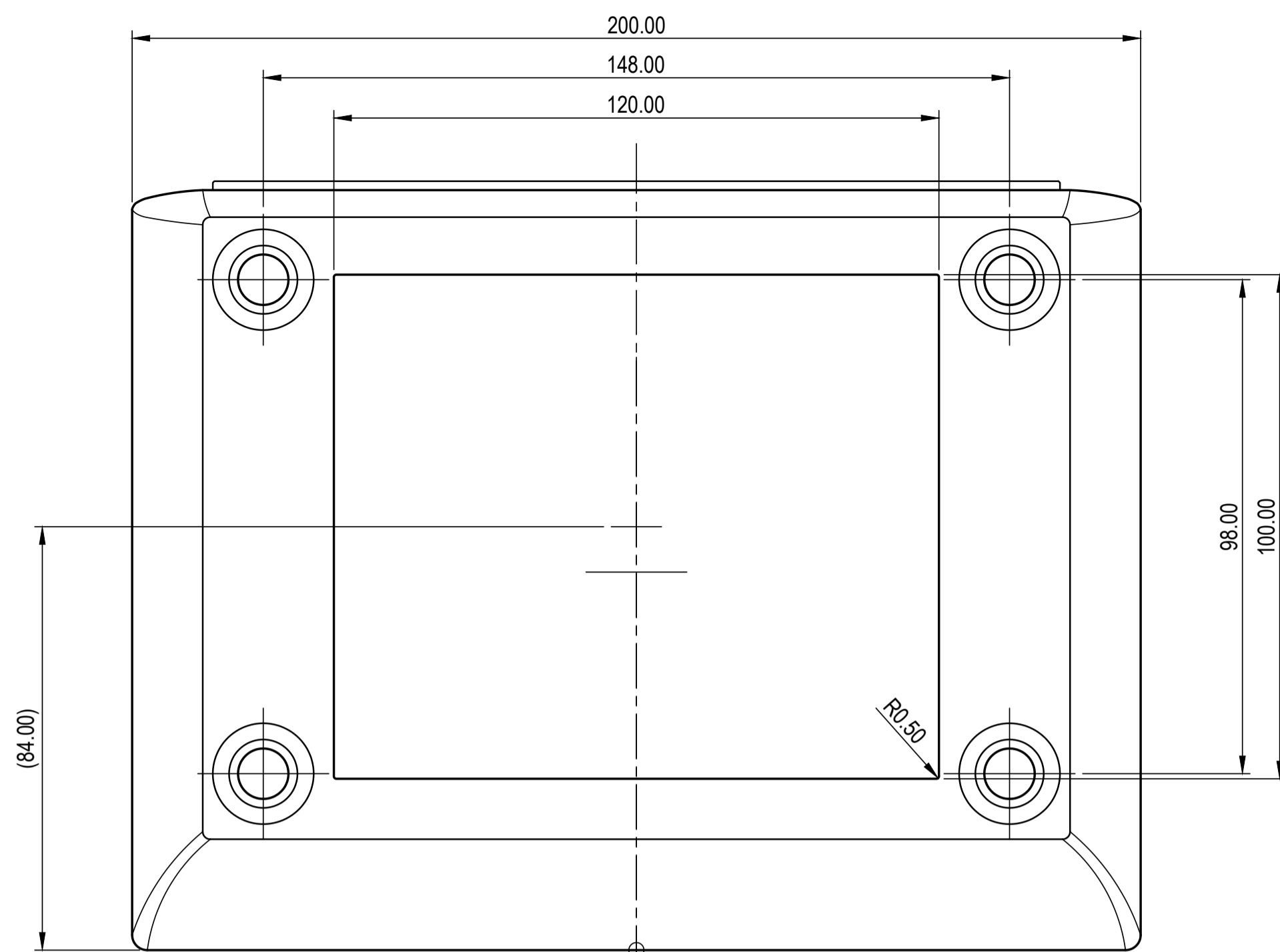

Unterteil-Unteransicht
BASE, OUTSIDE-VIEW

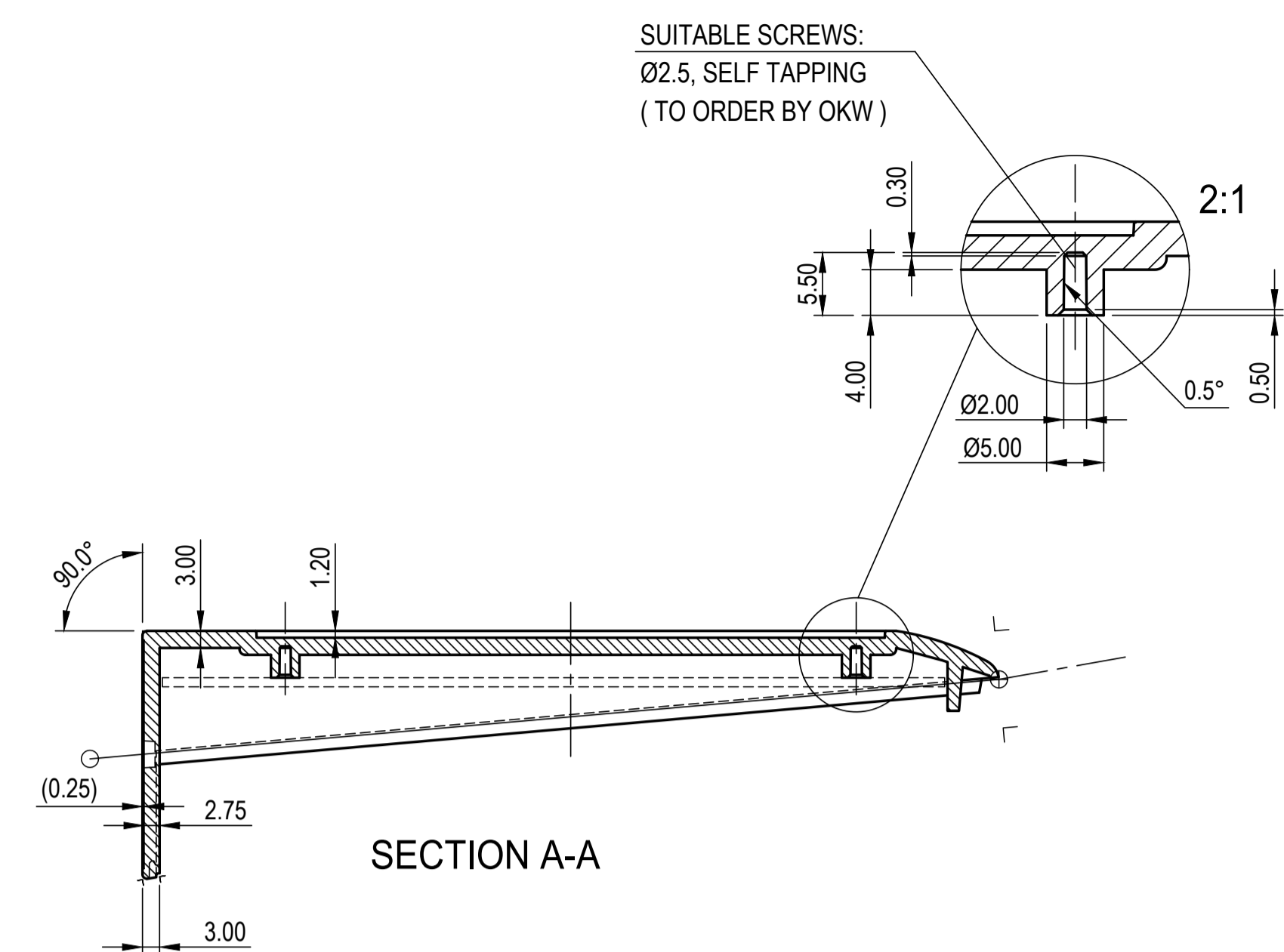

SECTION A-A

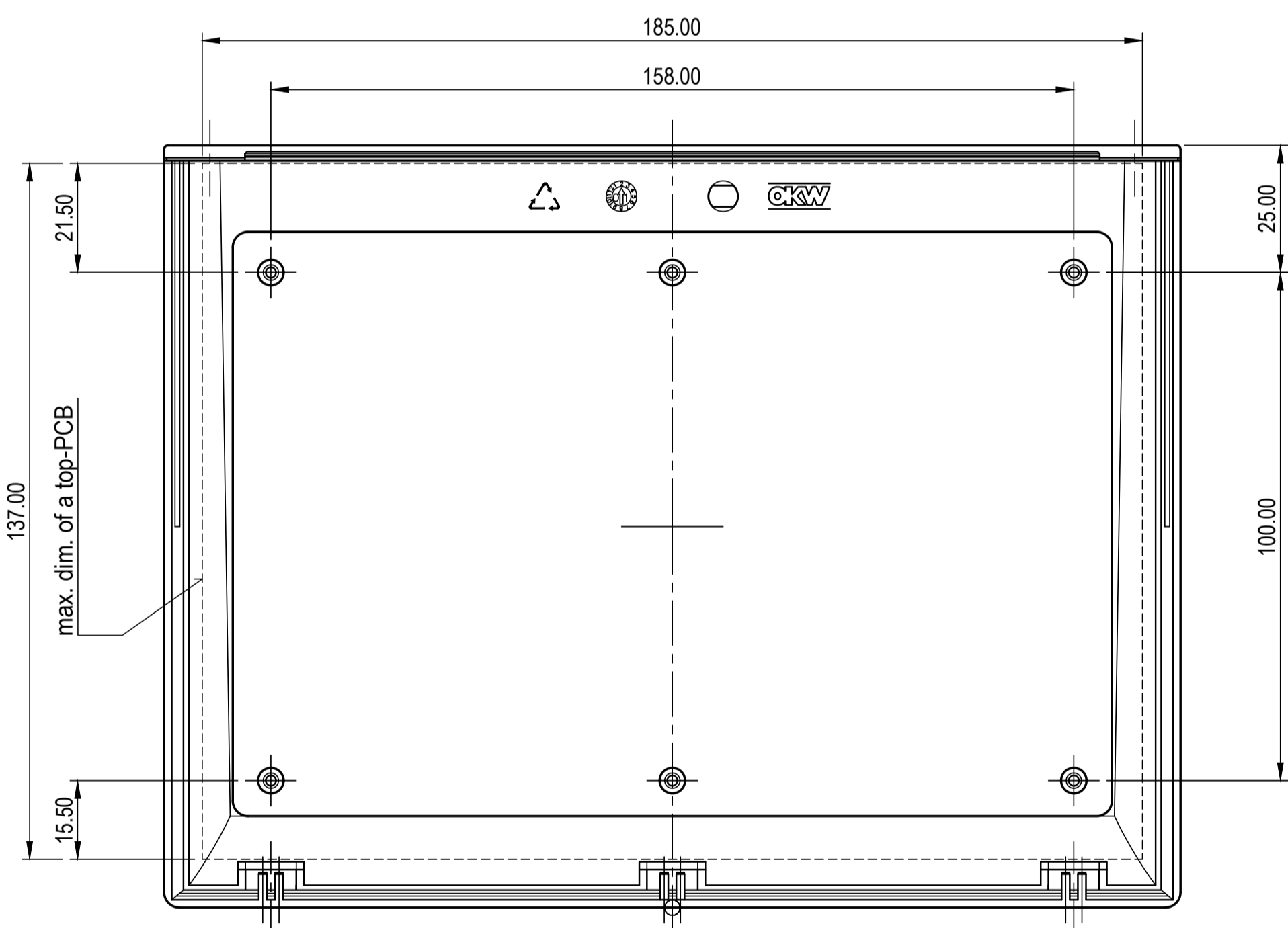

Oberteil-Innenansicht
TOP, REAL INSIDE-VIEW

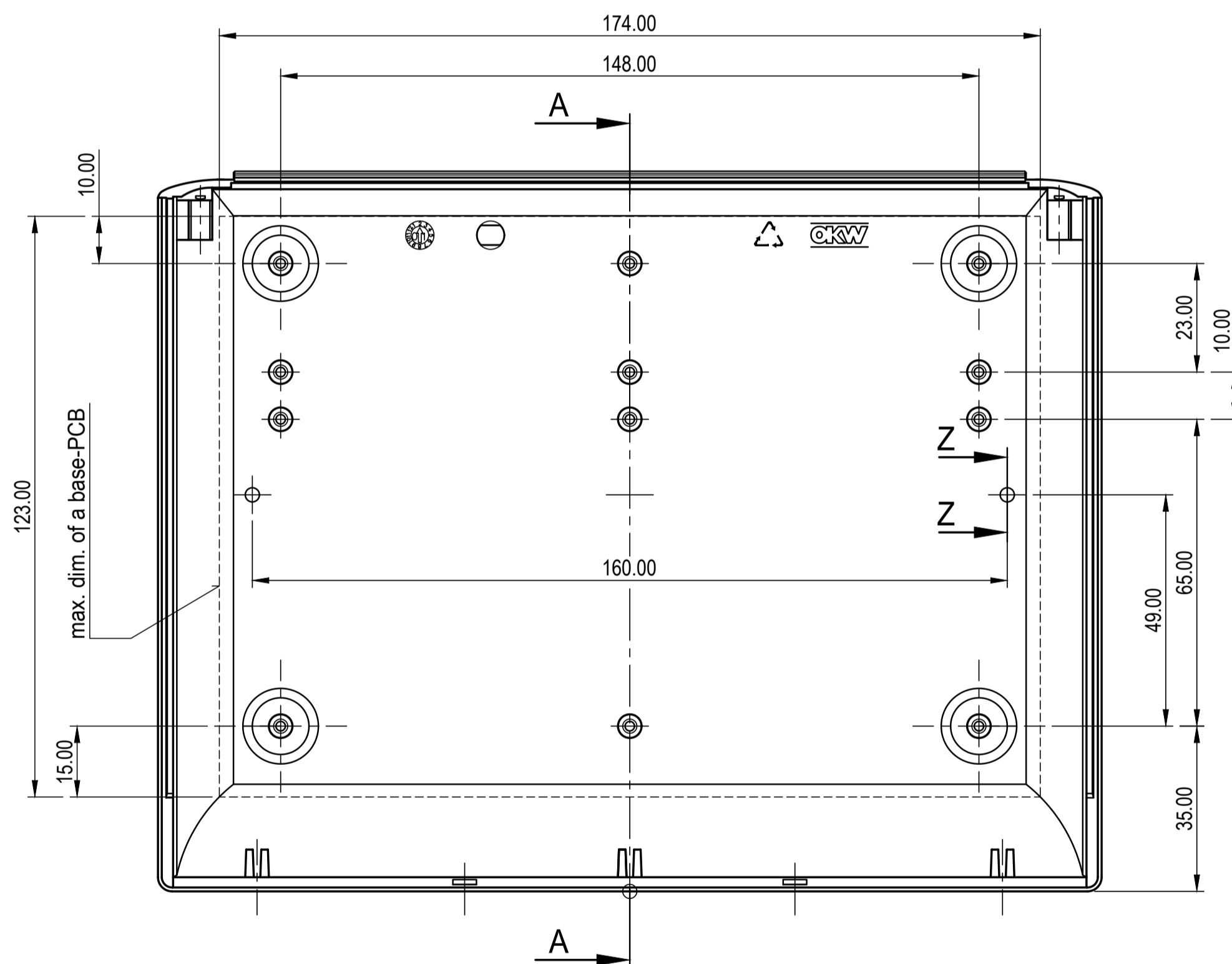

Unterteil-Innenansicht
BASE, INSIDE-VIEW

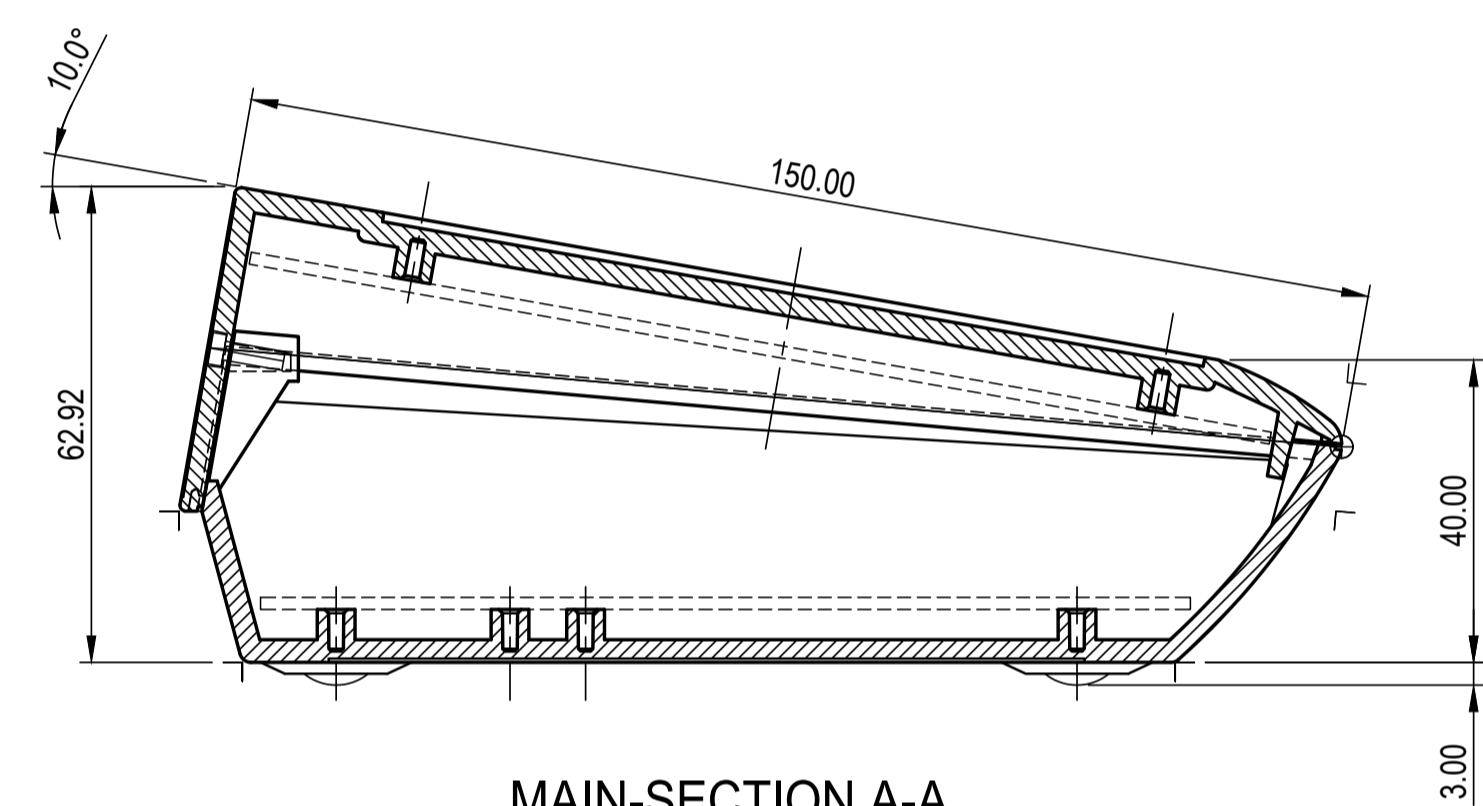

MAIN-SECTION A-A

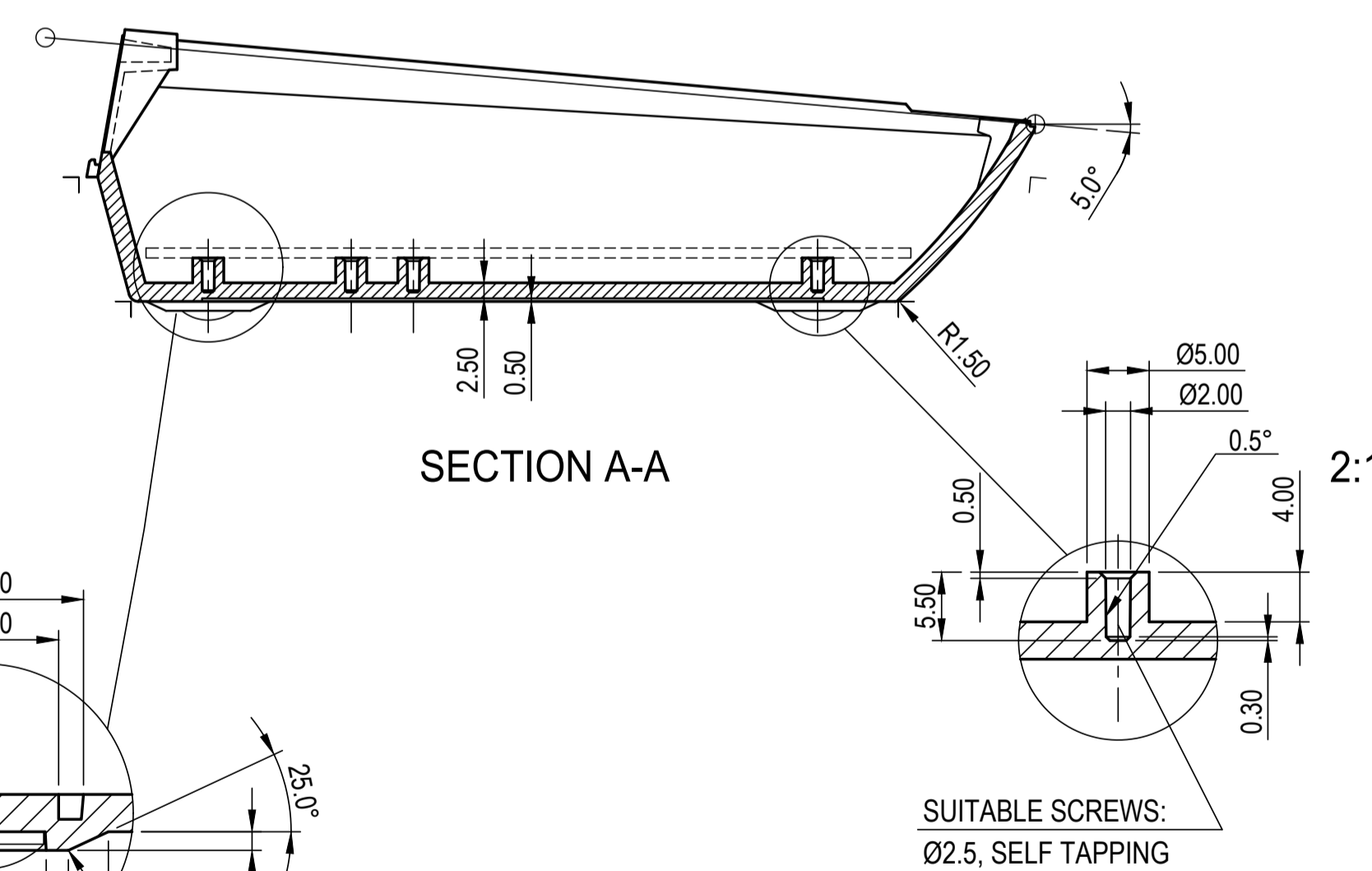

SECTION A-A

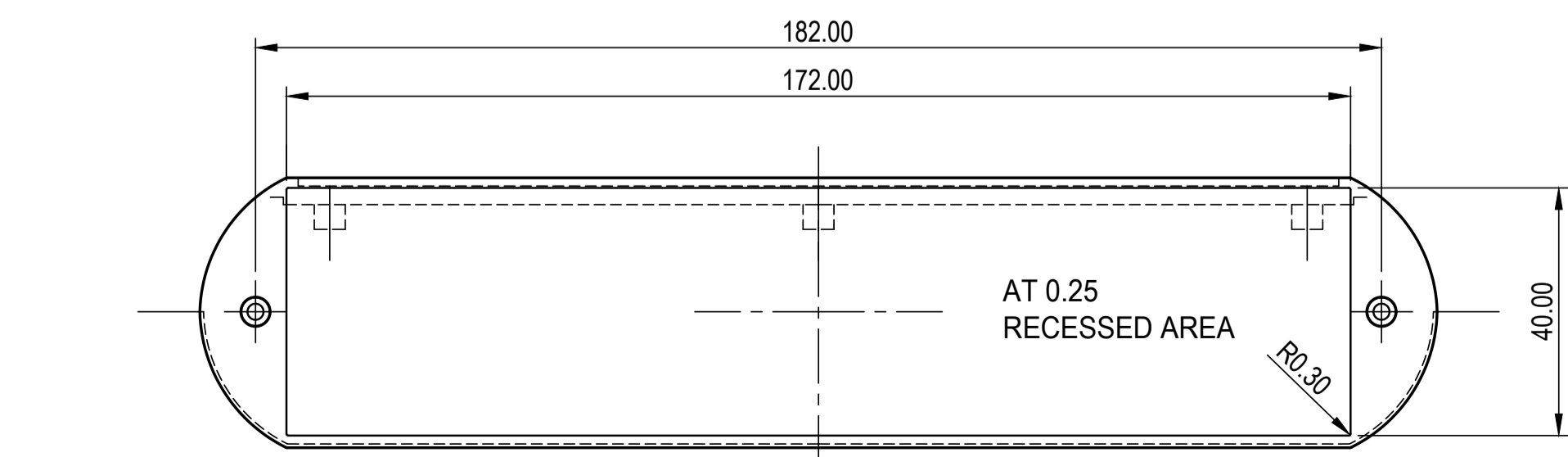

Oberteil-auf Flansch
TOP, REAL VIEW TO THE REAR

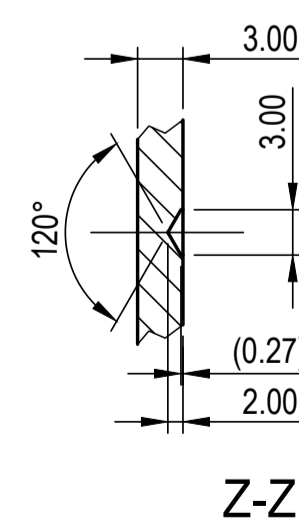

Z-Z

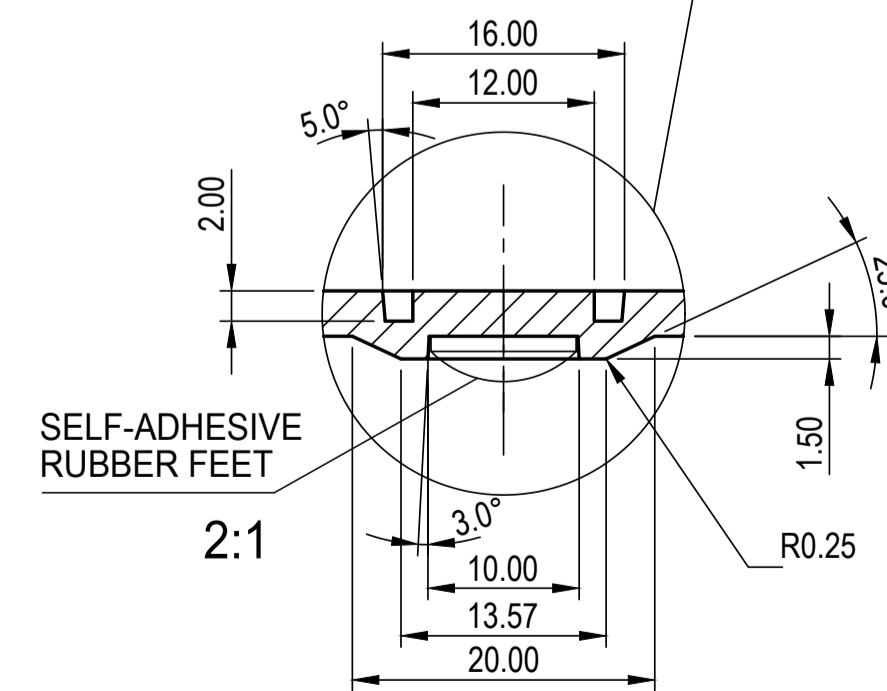

SELF-ADHESIVE
RUBBER FEET

2:1

Z (PZ1)

Bitte die Maße an aktuellen Teilen abnehmen.
Diese unterliegen material- und
produktionspezifischen Fertigungstoleranzen

Please take the dimensions from current parts.
These are subject to material- and
manufacturing-specific tolerances.

Informationskopie
wird nicht aktualisiert

Copy for Information
will not be updated

Technische Änderungen vorbehalten. Irrtümer und Druckfehler
begründen keinen Anspruch auf Schadensersatz. Wichtige Einbau-
maße bitte direkt mit dem aktuellen Produkt abstimmen.

Subject to technical modification without prior notice. Typographical
and other errors do not justify any claim for damages. All dimensions
should be verified using an actual modelled part.

Sous réserve de modifications techniques. Toute erreur ou faute
d'impression ne justifie aucune demande d'indemnisation. Nous
prions les clients de vérifier les dimensions des composants avec
les boîtiers avant le montage.

Erst am: 19.09.2000	Toleranzen:	Status:	SERIENFREIGABE
Erst von: Hasselb	DIN 16901 T130	Zeichnungsart:	
Freig am: 20.09.2013	Volumen:	Zeichnungsart:	DIN 6 Teil 2
Freig von:		Maßstab:	
Revision: 05	This document contains proprietary information of OKW Gehäusesysteme GmbH and is rendered subject to the conditions that the information be retained in confidence not be reproduced or copied and not be used or incorporated in any product.		1:1
OKW GEHÄUSE SYSTEME		COMTEC 200 VERSION I, H (HIGH) A062010*	Dateiname: 00000008