

Features

- Non-volatile Flash Memory
- Fast Read access Time =90 and -120 ns.
- Flash Electrical Chip-Erase
 - 5 Second Typical Chip-Erase
- Quick Programming Algorithm
 - 10 μ s Typical Byte-Program
 - 2 Second Chip-Program
- 12.0 V \pm 5% VPP chip erase
- 100,000 Erase/Program Cycles
- 10 year data retention
- CMOS Low Power Consumption
 - 10 mA Typical Active Current
 - 50 μ A Typical Standby Current
- Command Register Architecture for Microprocessor/Microcontroller Compatible Write Interface
- Great Noise Immunity Features
 - \pm 10% VCC Tolerance
- -40°C to +85°C operation – Industrial
-55°C to +125°C operation - Military
- Safely abort Erase or Program sequence at any time including Integrated Program/Erase Stop Timer
- Protection against inadvertent programming during power up.
- JEDEC-Standard Pinouts
 - 32-Pin Plastic Dip
 - 32-Lead PLCC
 - 32-Lead TSOP

General Description

The Tekmos TK28F010 is a high speed 1M CMOS non-volatile flash memory arranged as 128K x 8. (131,072 x 8 bits) It is electrically erasable and reprogrammable. It is well suited for use in applications where codes are changed after the initial programming, during manufacture, final test or after sale. Memory contents can be changed in a test fixture, in a PROM programmer, or in system.

The TK28F010 is manufactured to allow for low power consumption and immunity to noise. The device is designed to withstand 100,000 program/erase cycles without losing data integrity. Data retention is at least 10 years.

Standby current maximum is 100 μ A providing significant power saving when the device is deselected. Access time of 90 ns provides zero wait state performance compatible with many microcontrollers and microprocessors. Electrical erasure of the entire memory is typically achieved in less than 5 seconds. 12 volt programming and erase voltage makes it compatible with similar devices.

The erase procedure has a two-step process that ensures against accidental erasure of the contents of the memory. The erase command is actually written twice before it is executed. An integrated stop feature allows for automatic timing control eliminating the need for a maximum erase timing specification.

An Abort/Reset command is available to allow the user to safely abort an erase or program sequence. The abort/reset operation can interrupt at any time in a program or erase operation and the device is reset to the Read Mode.

Protection against inadvertent programming during power up is provided. V_{PP} and V_{CC} may be powered up in any order, no sequencing is required.

The TK28F010 is offered in 32-Pin Plastic DIP or 32-Lead PLCC and 32-Lead TSOP packages. Conforming to JEDEC standards, it is pin for pin compatible with standard EPROM and EEPROM devices. The TK28F010 is often used as a drop in replacement in systems originally designed for other manufacturer's 28F010 devices.

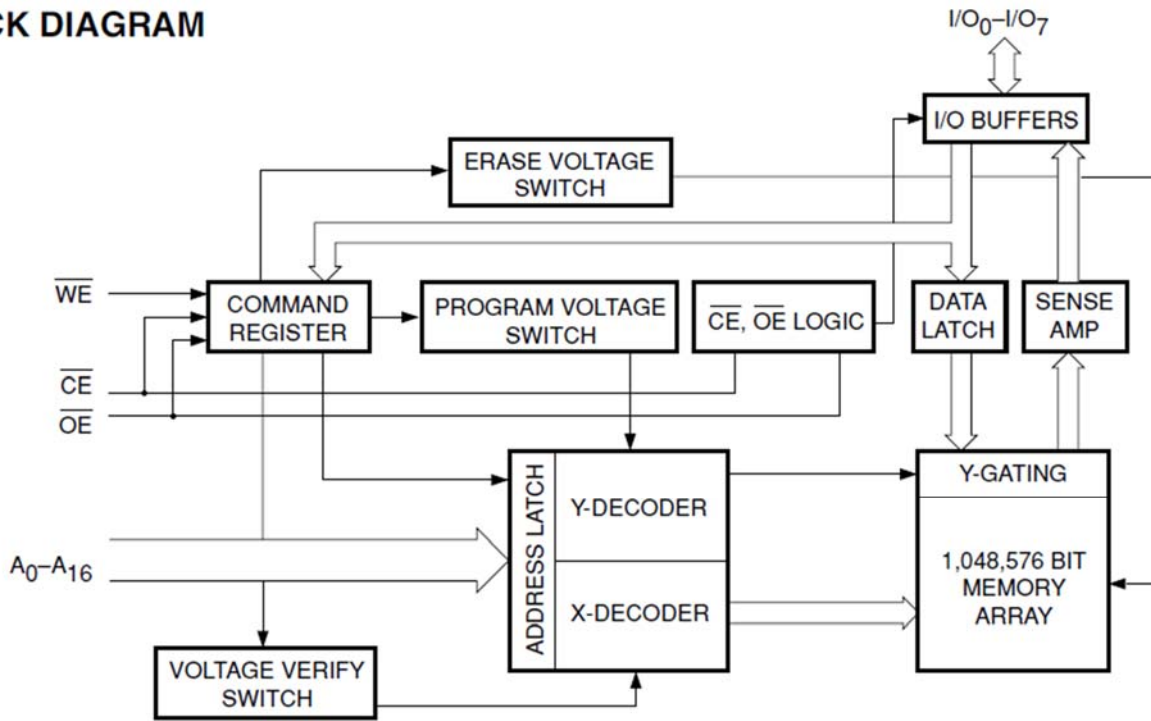
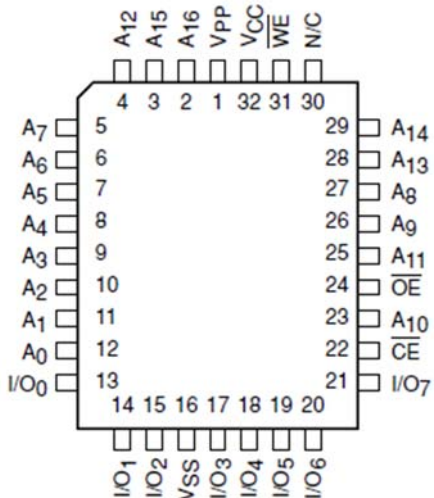
BLOCK DIAGRAM

Pin Configurations

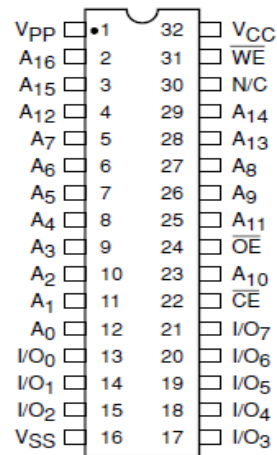
PLCC Package



PDIP Package



TSOP

Pin Functions

DIP/ PCC Pin #	TSOP Pin #	Pin Name	Type	Function	DIP/ PCC Pin #	TSOP Pin #	Pin Name	Type	Function
1	9	V _{PP}	Input	Program Erase Voltage Supply	17	25	I/O 3	Input	Data Input/ Output
2	10	A16	Input	Address memory	18	26	I/O 4	Input	Data Input/ Output
3	11	A15	Input	Address memory	19	27	I/O 5	Input	Data Input/ Output
4	12	A12	Input	Address memory	20	28	I/O 6	Input	Data Input/ Output
5	13	A7	Input	Address memory	21	29	I/O 7	Input	Data Input/ Output
6	14	A6	Input	Address memory	22	30	\overline{CE}	Input	Chip Enable
7	15	A5	Input	Address memory	23	31	A10	Input	Address memory
8	16	A4	Input	Address memory	24	32	\overline{OE}	Input	Output Enable
9	17	A3	Input	Address memory	25	1	A11	Input	Address memory
10	18	A2	Input	Address memory	26	2	A9	Input	Address memory
11	19	A1	Input	Address memory	27	3	A8	Input	Address memory
12	20	A0	Input	Address memory	28	4	A13	Input	Address memory
13	21	I/O 0	I/O	Data Input/ Output	29	5	A14	Input	Data Input/ Output
14	22	I/O 1	I/O	Data Input/ Output	30	6	N/C	---	No Connection
15	23	I/O 2	I/O	Data Input/ Output	31	7	\overline{WE}	Input	Data Input/ Output
16	24	V _{SS}	Supply	Ground	32	8	V _{CC}	Supply	Voltage Supply

Absolute Maximum Ratings*

Temperature Under Bias	-40°C to +85°C
Storage Temperature	-55°C to +150°C
Voltage on Any Pin with Respect to Ground ⁽¹⁾	-0.5V to +V _{CC} + 0.5V
Voltage on Pin A ₉ with Respect to Ground ⁽¹⁾	-0.5V to +13.5V
V _{PP} with Respect to Ground during Program/Erase ⁽¹⁾	-0.5V to +14.0V
Package Power Dissipation Capability (T _A = 25°C)	1.0 W
Lead Soldering Temperature (10 seconds)	300°C
Output Short Circuit Current ⁽²⁾	100 mA

Reliability Characteristics

Symbol	Parameter	Min	Max	Units	Test Method
N _{END} ⁽³⁾	Endurance	100K		Cycles/Byte	MIL-STD-883, Test Method 1033
T _{DR} ⁽³⁾	Data Retention	10		Years	MIL-STD-883, Test Method 1008
V _{ZAP} ⁽³⁾	ESD Susceptibility	2000		Volts	MIL-STD-883, Test Method 3015
I _{LTH} ⁽³⁾⁽⁴⁾	Latch-Up	100		mA	JEDEC Standard 17

CAPACITANCE T_A = 25°C, f = 1.0 MHz

Symbol	Test	Limits		Units	Conditions
		Min	Max.		
C _{IN} ⁽³⁾	Input Pin Capacitance		6	pF	V _{IN} = 0V
C _{OUT} ⁽³⁾	Output Pin Capacitance		10	pF	V _{OUT} = 0V
C _{VPP} ⁽³⁾	V _{PP} Supply Capacitance		25	pF	V _{PP} = 0V

NOTE: Stresses above those listed under “Absolute Maximum Ratings” may cause permanent damage to the device. These are stress ratings only, and functional operation of the device at these or any other conditions outside of those listed in the operational sections of this specification is not implied. Exposure to any absolute maximum rating for extended periods may affect device performance and reliability.

Other Notes:

- (1) The minimum DC input voltage is -0.5V. During transitions, inputs may undershoot to -2.0V for periods of less than 20 ns. Maximum DC voltage on output pins is V_{CC} + 0.5V, which may overshoot to V_{CC} + 2.0V for periods of less than 20ns.
- (2) Output shorted for no more than one second. No more than one output shorted at a time.
- (3) This parameter is tested initially and after a design or process change that affects the parameter.
- (4) Latch-up protection is provided for stresses up to 100 mA on address and data pins from -1V to V_{CC} + 1V.

D.C. Operating Characteristics ($V_{CC} = +5V \pm 10\%$, unless otherwise specified)

Symbol	Parameter	Limits			Test Conditions
		Min.	Max.	Unit	
I_{LI}	Input Leakage Current		± 1	μA	$V_{IN} = V_{CC}$ or V_{SS} $V_{CC} = 5.5V$, $OE = V_{IH}$
I_{LO}	Output Leakage Current		± 1	μA	$V_{OUT} = V_{CC}$ or V_{SS} , $V_{CC} = 5.5V$, $OE = V_{IH}$
I_{SB1}	V_{CC} Standby Current CMOS		100	μA	$CE = V_{CC} \pm 0.5V$, $V_{CC} = 5.5V$
I_{SB2}	V_{CC} Standby Current TTL		1	mA	$\overline{CE} = V_{IH}$, $V_{CC} = 5.5V$
I_{CC1}	V_{CC} Active Read Current		30	mA	$V_{CC} = 5.5V$, $\overline{CE} = V_{IL}$, $I_{OUT} = 0mA$, $f = 6 MHz$
$I_{CC2}^{(1)}$	V_{CC} Programming Current		15	mA	$V_{CC} = 5.5V$, Programming in Progress
I_{CC3}	V_{CC} Erase Current		15	mA	$V_{CC} = 5.5V$, Erase in Progress
I_{CC4}	V_{CC} Prog./Erase Verify Current		15	mA	$V_{CC} = 5.5V$, Program or Erase Verify in Progress
I_{PPS}	V_{PP} Standby Current		± 10	μA	$V_{PP} = V_{PPL}$
I_{PP1}	V_{PP} Read Current		200	μA	$V_{PP} = V_{PPH}$
$I_{PP2}^{(1)}$	V_{PP} Programming Current		30	mA	$V_{PP} = V_{PPH}$, Programming in Progress
$I_{PP3}^{(1)}$	V_{PP} Erase Current		30	mA	$V_{PP} = V_{PPH}$, Erase in Progress
$I_{PP4}^{(1)}$	V_{PP} Prog./Erase Verify Current		5	mA	$V_{PP} = V_{PPH}$, Program or Erase Verify in Progress
V_{IL}	Input Low Level TTL	-0.5	0.8	V	
V_{ILC}	Input Low Level CMOS	-0.5	0.8	V	
V_{OL}	Output Low Level		0.45	V	$I_{OL} = 5.8mA$, $V_{CC} = 4.5V$
V_{IH}	Input High Level TTL	2	$V_{CC} + 0.5$	V	
V_{IHC}	Input High Level CMOS	$V_{CC} * 0.7$	$V_{CC} + 0.5$	V	
V_{OH1}	Output High Level TTL	2.4		V	$I_{OH} = -2.5mA$, $V_{CC} = 4.5V$
V_{OH2}	Output High Level CMOS	$V_{CC} - 0.4$		V	$I_{OH} = -400\mu A$, $V_{CC} = 4.5V$
V_{ID}	A9 Signature Voltage	11.4	13	V	$A_9 = V_{ID}$
$I_{ID}^{(1)}$	A9 Signature Current		200	μA	
V_{LO}	V_{CC} Erase/Prog. Lockout Voltage	2.5		V	

Note: (1) This parameter is tested initially and after a design or process change that affects the parameter.

SUPPLY CHARACTERISTICS

Symbol	Parameter	Limits		Unit
		Min	Max.	
V _{CC}	V _{CC} Supply Voltage	4.5	5.5	V
V _{PPL}	V _{PP} During Read Operations	0	V _{CC} +0.5	V
V _{PPH}	V _{PP} During Read/Erase/Program	11.4	12.6	V

A.C. CHARACTERISTICS, Read Operation

V_{CC} = +5V ±10%, unless otherwise specified. Temperature -40°C to +85°C, unless otherwise specified.

JEDEC Symbol	Standard Symbol	Parameter	Min	Max	Unit
t _{AVAV}	t _{RC}	Read Cycle Time	90		ns
t _{ELQV}	t _{CE}	\overline{CE} Access Time		90	ns
t _{AVQV}	t _{ACC}	Address Access Time		90	ns
t _{GLQV}	t _{OE}	\overline{OE} Access Time		55	ns
t _{AXQX}	t _{OH}	Output Hold from Address $\overline{OE}/\overline{CE}$ Change	0		ns
t _{GLQX}	t _{OLZ} ⁽¹⁾⁽⁶⁾	\overline{OE} to Output in Low-Z	0		ns
t _{ELZX}	t _{LZ} ⁽¹⁾⁽⁶⁾	\overline{CE} to Output in Low-Z	0		ns
t _{GHQZ}	t _{DF} ⁽¹⁾⁽²⁾	\overline{OE} High to Output High-Z		20	ns
t _{EHQZ}	t _{DF} ⁽¹⁾⁽²⁾	\overline{CE} High to Output High-Z		30	ns
t _{WHGL} ⁽¹⁾		Write Recovery Time Before Read	6		μs

Figure 1. A.C. Testing Input / Output Waveforms⁽³⁾⁽⁴⁾⁽⁵⁾

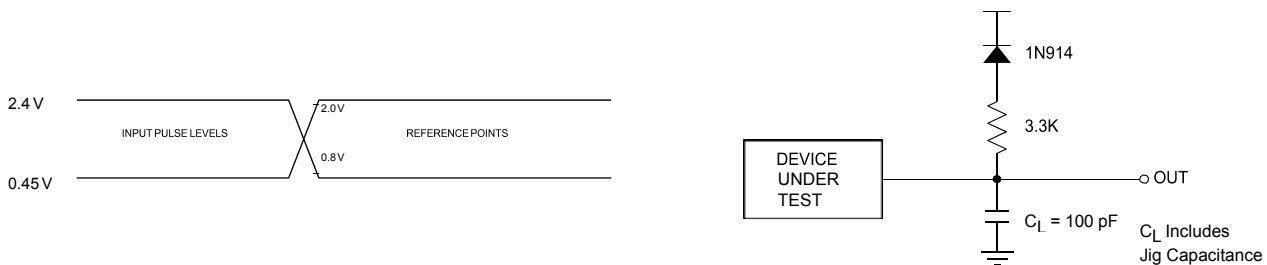

⁵¹This parameter is tested initially and after a design or process change that affects the parameter.

- (1) Output floating (High-Z) is defined as the state where the external data line is no longer driven by the output buffer.
 (2) Input Rise and Fall Times (10% to 90%) < 10 ns.

- (3) Input Pulse Levels = 0.45V and 2.4V. For High Speed Input Pulse Levels 0.0V and 3.0V.
 (4) Input and Output Timing Reference = 0.8V and 2.0V. For High Speed Input and Output Timing Reference = 1.5V.
 (5) Low-Z is defined as the state where the external data may be driven by the output buffer but may not be valid.
 (6) For load and reference points, see Fig. 1

A.C. CHARACTERISTICS, Program/Erase Operation

$V_{CC} = +5V \pm 10\%$, unless otherwise specified.

JEDEC Symbol	Standard Symbol	Parameter	Min	Typ	Max	Unit
t_{AVAV}	t_{WC}	Write Cycle Time	90			ns
t_{AVWL}	t_{AS}	Address Setup Time	0			ns
t_{WLAX}	t_{AH}	Address Hold Time	40			ns
t_{DVWH}	t_{DS}	Data Setup Time	40			ns
t_{WHDX}	t_{DH}	Data Hold Time	10			ns
t_{ELWL}	t_{CS}	\overline{CE} Setup Time	0			ns
t_{WHEH}	t_{CH}	\overline{CE} Hold Time	0			ns
t_{WLWH}	t_{WP}	\overline{WE} Pulse Width	40			ns
t_{WHWL}	t_{WPH}	\overline{WE} High Pulse Width	20			ns
$t_{WHWH1}^{(2)}$	-	Program Pulse Width	10			μ S
$t_{WHWH2}^{(2)}$	-	Erase Pulse Width	9.5			ms
t_{WHGL}	-	Write Recovery Time Before	6			μ S
t_{GHWL}	-	Read Recovery Time Before	0			μ S
t_{VPEL}	-	V_{PP} Setup Time to \overline{CE}	100			ns

Erase and Programming Performance ⁽¹⁾

Parameter	Min	Typ	Max	Unit
Chip Erase Time (3)		0.5	10	Sec
Chip Program Time (3)(4)		2	12.5	Sec

Note:

- (1) Please refer to Supply characteristics for the value of V_{PPH} and V_{PPL} . The V_{PP} supply can be either hardwired or switched. If V_{PP} is switched, V_{PPL} can be ground, less than $V_{CC} + 2.0V$ or a no connect with a resistor tied to ground.
 (2) Program and Erase operations are controlled by internal stop timers.
 (3) 'Typicals' are not guaranteed, but based on characterization data. Data taken at 25°C, 12.0V V_{PP} .
 (4) Minimum byte programming time (excluding system overhead) is 16 μ S (10 μ S program + 6 μ S write recovery), while maximum is 400 μ S/byte (16 μ S x 25 loops). Max chip programming time is specified lower than the worst case allowed by the programming algorithm since most bytes program significantly faster than the worst case byte.

Function Table⁽¹⁾

Mode	Pins					Notes
	$\overline{\text{CE}}$	$\overline{\text{OE}}$	$\overline{\text{WE}}$	V_{PP}	I/O	
Read	V_{IL}	V_{IL}	V_{IH}	V_{PPL}	D_{OUT}	
Output Disable	V_{IL}	V_{IH}	V_{IH}	X	High-Z	
Standby	V_{IH}	X	X	V_{PPL}	High-Z	
Signature (MFG)	V_{IL}	V_{IL}	V_{IH}	X	31H	$A_0 = V_{\text{IL}}, A_9 = 12\text{V}$
Signature (Device)	V_{IL}	V_{IL}	V_{IH}	X	B4H	$A_0 = V_{\text{IH}}, A_9 = 12\text{V}$
Program/Erase	V_{IL}	V_{IH}	V_{IL}	V_{PPH}	D_{IN}	See Command Table
Write Cycle	V_{IL}	V_{IH}	V_{IL}	V_{PPH}	D_{IN}	During Write Cycle
Read Cycle	V_{IL}	V_{IL}	V_{IH}	V_{PPH}	D_{OUT}	During Write Cycle

Write Command Table

Commands are written into the command register in one or two write cycles. The command register can be altered only when V_{PP} is high and the instruction byte is latched on the rising edge of $\overline{\text{WE}}$. Write cycles also internally latch addresses and data required for programming and erase operations.

Mode	Pins						
	First Bus Cycle			Second Bus Cycle			
	Operation	Address	D_{IN}	Operation	Address	D_{IN}	D_{OUT}
Set Read	Write	X	00H	Read	A_{IN}		D_{OUT}
Read Sig. (MFG)	Write	X	90H	Read	00		31H
Read Sig. (Device)	Write	X	90H	Read	01		B4H
Erase	Write	X	20H	Write	X	20H	
Erase Verify	Write	A_{IN}	A0H	Read	X		D_{OUT}
Program	Write	X	40H	Write	A_{IN}	D_{IN}	
Program Verify	Write	X	C0H	Read	X		D_{OUT}
Reset	Write	X	FFH	Write	X	FFH	

Note:

(1) Logic Levels: X = Logic 'Do not care' ($V_{\text{IH}}, V_{\text{IL}}, V_{\text{PPL}}, V_{\text{PPH}}$)

READ OPERATIONS

Read Mode

A Read operation is performed with both \overline{CE} and \overline{OE} low and with \overline{WE} high. V_{PP} can be either high or low, however, if V_{PP} is high, the Set READ command has to be sent before reading data (see Write Operations). The data retrieved from the I/O pins reflects the contents of the memory location corresponding to the state of the 17 address pins. The respective timing waveforms for the read operation are shown in Figure 3. Refer to the AC Read characteristics for specific timing parameters.

Signature Mode

The signature mode allows the user to identify the IC manufacturer and the type of device while the device resides in the target system. This mode can be activated in either of two ways; through the conventional method of applying a high voltage (12V) to address pin A9 or by sending an instruction to the command register (see Write Operations).

The conventional mode is entered as a regular READ mode by driving the \overline{CE} and \overline{OE} pins low (with \overline{WE} high), and applying the required high voltage on address pin A9 while all other address lines are held at V_{IL} .

A Read cycle from address 0000H retrieves the binary code for the IC manufacturer on outputs I/O₀ to I/O₇:

$$\text{Tekmos Code} = 0011\ 0100\ (34H)$$

A Read cycle from address 0001H retrieves the binary code for the device on outputs I/O₀ to I/O₇.

$$28F010\ \text{Code} = 1011\ 0100\ (B4H)$$

Standby Mode

With \overline{CE} at a logic-high level, the TK28F010 is placed in a standby mode where most of the device circuitry is disabled, thereby substantially reducing power consumption. The outputs are placed in a high-impedance state.

Figure 3. A.C. Timing for Read Operation

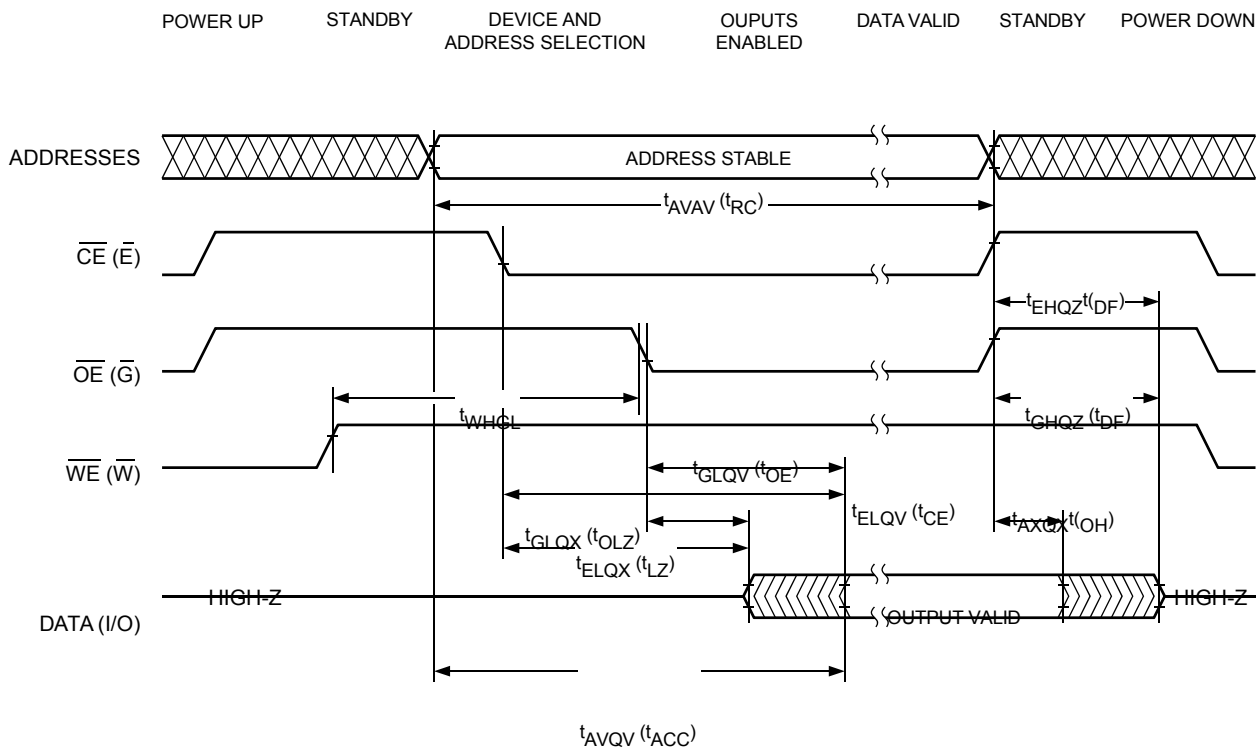

WRITE OPERATIONS

The following operations are initiated by observing the sequence specified in the Write Command Table.

Read Mode

The device can be put into a standard READ mode by initiating a write cycle with 00H on the data bus. The subsequent read cycles will be performed similar to a standard EPROM or EEPROM Read.

Signature Mode

An alternative method for reading device signature (see Read Operations Signature Mode), is initiated by writing the code 90H into the command register while keeping V_{PP} high. A read cycle from address 0000H with \overline{CE} and \overline{OE} low (and \overline{WE} high) will output the device signature.

Tekmos Code = 0011 0100 (34H)

A Read cycle from address 0001H retrieves the binary code for the device on outputs I/O₀ to I/O₇.

28F010 Code = 1011 0100 (B4H)

Figure 4. A.C. Timing for Erase Operation

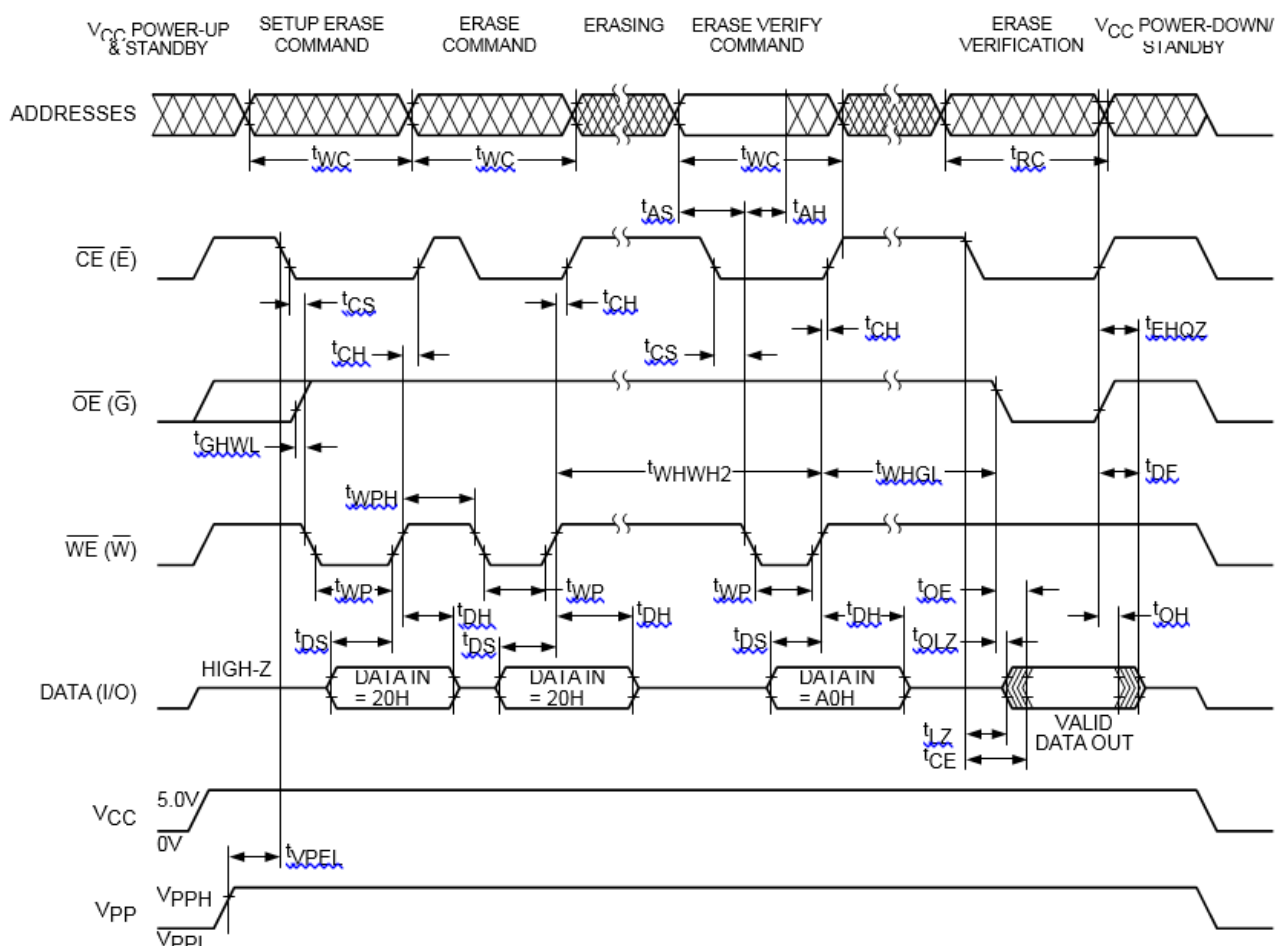
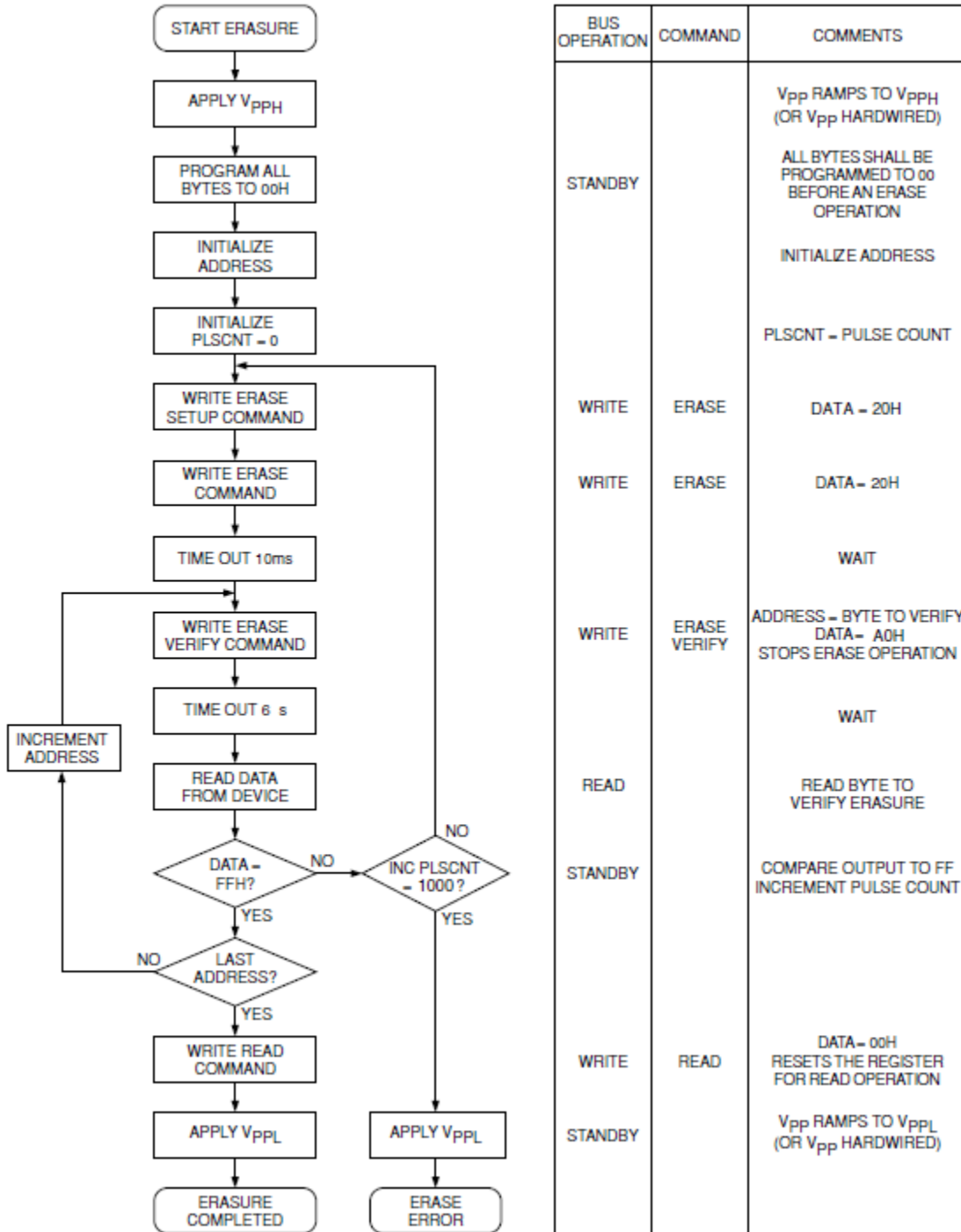

Figure 5. Chip Erase Algorithm⁽¹⁾

Note:

(1) The algorithm MUST BE FOLLOWED to ensure proper and reliable operation of the device

Erase Mode

During the first Write cycle, the command 20H is written into the command register. In order to commence the erase operation, the identical command of 20H has to be written again into the register. This two-step process ensures against accidental erasure of the memory contents. The final erase cycle will be stopped at the rising edge of \overline{WE} , at which time the Erase Verify command (A0H) is sent to the command register. During this cycle, the address to be verified is sent to the address bus and latched when \overline{WE} goes low. An integrated stop timer allows for automatic timing control over this operation, eliminating the need for a maximum erase timing specification. Refer to AC Characteristics (Program/Erase) for specific timing parameters.

Erase-Verify Mode

The Erase-Verify operation is performed on every byte after each erase pulse to verify that the bits have been erased.

Programming Mode

The programming operation is initiated using the programming algorithm of Figure 7. During the first write cycle, the command 40H is written into the command register. During the second write cycle, the address of the memory location to be programmed is latched on the falling edge of \overline{WE} , while the data is latched on the rising edge of \overline{WE} . The program operation terminates with the next rising edge of \overline{WE} . An integrated stop timer allows for automatic timing control over this operation, eliminating the need for a maximum program timing specification. Refer to AC Characteristics (Program/Erase) for specific timing parameters.

Figure 6. A.C. Timing for Programming Operation

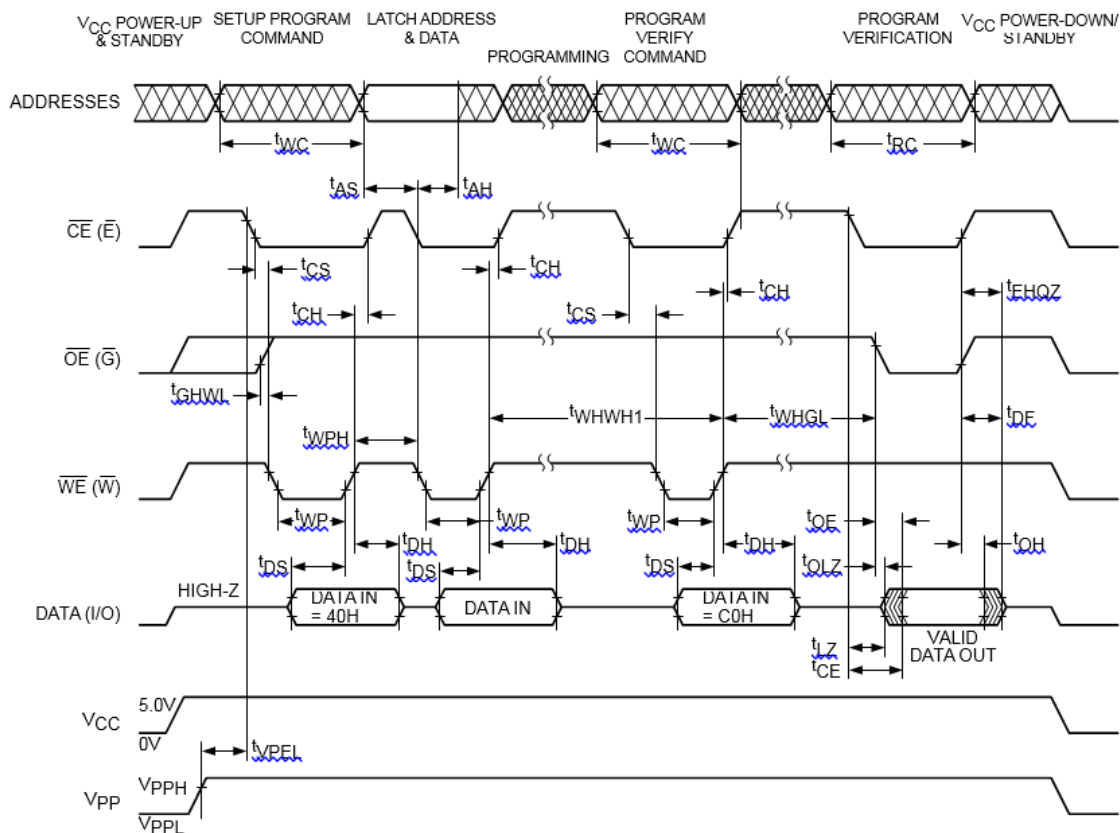
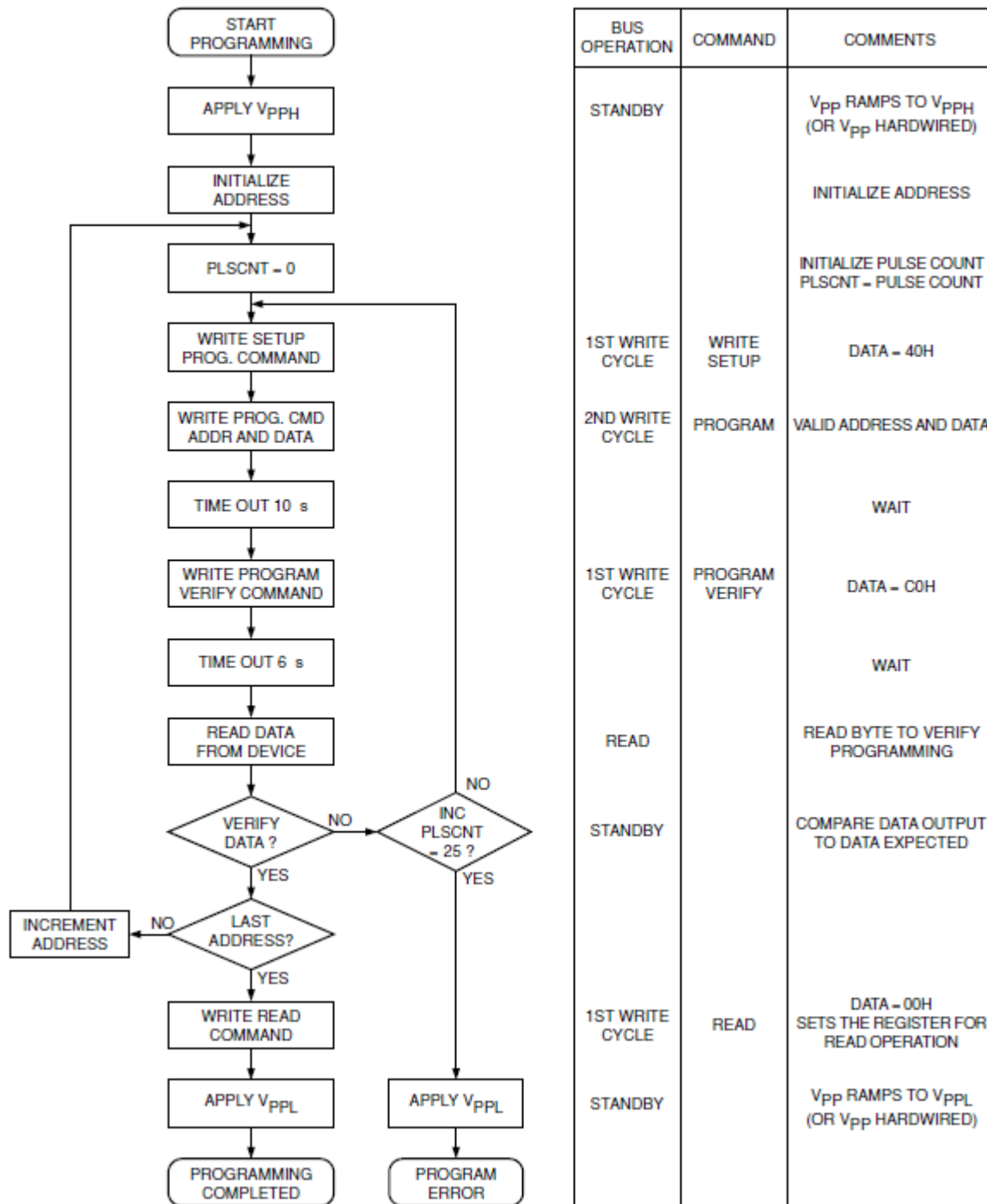

Figure 7. Programming Algorithm⁽¹⁾

Note:

(1) The algorithm MUST BE FOLLOWED to ensure proper and reliable operation of the device

Program-Verify Mode

A Program-Verify cycle is performed to ensure that all bits have been correctly programmed following each byte programming operation. The specific address is already latched from the write cycle just completed, and stays latched until the verify is completed. The Program-Verify operation is initiated by writing C0H into the command register. An internal reference generates the necessary high voltages so that the user does not need to modify V_{CC} . Refer to AC Characteristics (Program/Erase) for specific timing parameters.

Abort/Reset

An Abort/Reset command is available to allow the user to safely abort an erase or program sequence. Two consecutive program cycles with FFH on the data bus will abort an erase or a program operation. The abort/ reset operation can interrupt at any time in a program or erase operation and the device is reset to the Read Mode.

POWER UP/DOWN PROTECTION

The TK28F010 offers protection against inadvertent programming during V_{PP} and V_{CC} power transitions. When powering up the device there is no power-on sequencing necessary. In other words, V_{PP} and V_{CC} may power up in any order. Additionally V_{PP} may be hardwired to V_{PPH} independent of the state of V_{CC} and any power up/down cycling. The internal command register of the TK28F010 is reset to the Read Mode on power up.

POWER SUPPLY DECOUPLING

To reduce the effect of transient power supply voltage spikes, it is good practice to use a 0.1 μF ceramic capacitor between V_{CC} and V_{SS} and V_{PP} and V_{SS} . These high-frequency capacitors should be placed as close as possible to the device for optimum decoupling.

Figure 8. Alternate A.C. Timing for Program Operation

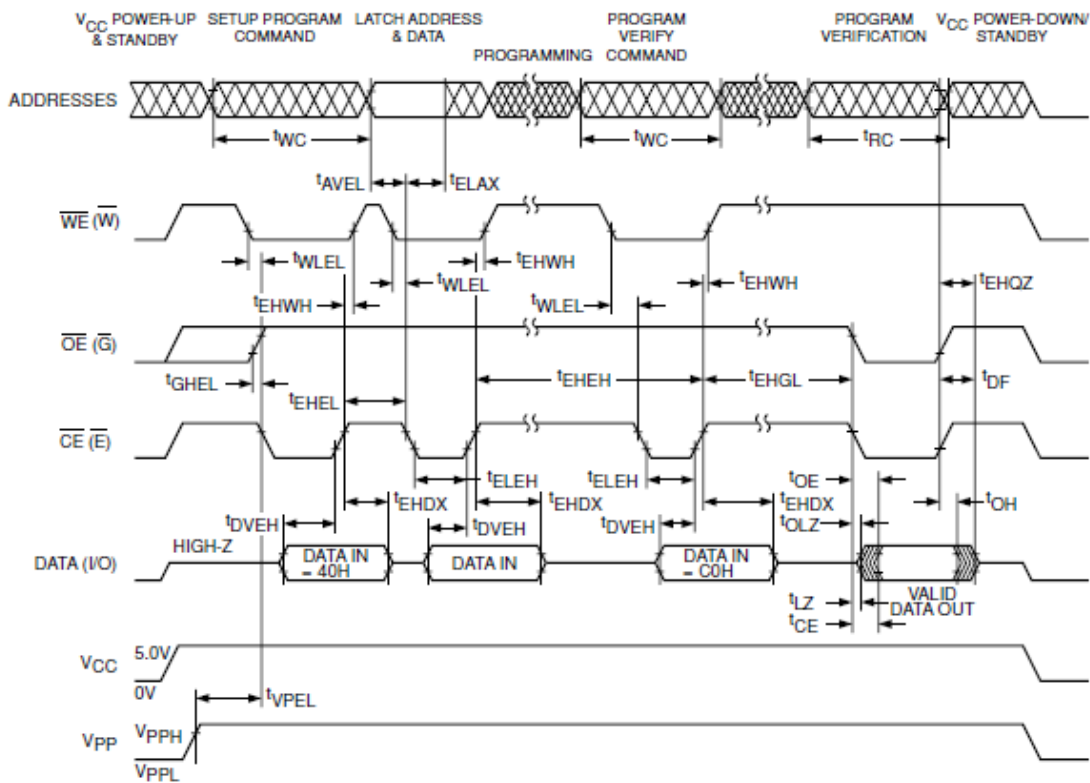

Ordering Information

Package	Temperature	Speed	Order Number
32 Pin PLCC	-40°C to +85°C	120 ns	TK28F010NI-12
32 Pin PLCC	-40°C to +85°C	90 ns	TK28F010NI-90
32 Pin PLCC	-55°C to +125°C	95 ns	TK28F010NM-95

The PDIP and TSOP packages are available on request. Contact the factory for details.

Part Marking Information

Parts that have been screened to the military temperature range are marked with a gold dot.

Contact Information

The TK28F010 can be ordered directly from Tekmos:

Tekmos, Inc.
7901 E Riverside Rd.
Bldg. 2, Suite 150
Austin, TX 78744
512 342-9871 phone

Sales@Tekmos.Com
www.Tekmos.com

Revision History

Date	Revision	Description
1/08/15	1.0	Initial Release
9/24/15	2.0	Specification Data Added
1/27/17	2.1	Ordering Information for 90ns added,
4/11/17	2.2	Correct pin numbering. Make military part a -95 speed

© 2017 Tekmos, Inc.

Information contained in this publication regarding device applications and the like is intended for suggestion only and may be superseded by updates. No representation or warranty is given and no liability is assumed by Tekmos Incorporated with respect to the accuracy or use of such information, or infringement of patents or other intellectual property rights arising from such use or otherwise. Use of Tekmos' products as critical components in life support systems is not authorized except with express written approval by Tekmos. No licenses are conveyed, implicitly or otherwise, under any intellectual property rights. The Tekmos logo and name are registered trademarks of Tekmos, Inc. All rights reserved. All other trademarks mentioned herein are the property of their respective companies. All rights reserved.

Terms and product names in this document may be trademarks of others.