



User Guide

UG000401

AS5x47U Adapter Board

Adapter Board User Manual

AS5047U & AS5147U

v1-00 • 2018-Oct-31

Content Guide

Content Guide	2	4.2	One Device SPI Mode, Bidirectional – 4 Wire, 5V Operation	8
1 Introduction	3	5	AS5x47U-TS_EK_AB Hardware	9
1.1 Kit Content.....	3	5.1	Schematics.....	9
1.2 Ordering Information	3	5.2	Layout	10
2 Board Description	4	6	Revision Information	11
2.1 Mounting the AS5X47U Adapter Board	5	7	Legal Information	12
3 Adapter Board and Pinout	6			
4 Operation Case	7			
4.1 One Device SPI Mode, Bidirectional – 4 Wire, 3V3 Operation.....	7			

1 Introduction

The AS5x47U adapter board is a small PCB allowing simple and quick testing or evaluation of the AS5x47U magnetic position sensor without the need to build a test fixture or design an own PCB.

AS5x47U-TS_EK_AB can be assembled with an AS5047U or AS5147U sensor.

1.1 Kit Content

Figure 1:
Adapter Board

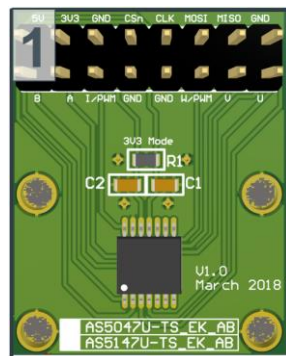

Figure 2:
Diametric Magnet



Pos.	Item	Comment
1	AS5x47U-TS_EK_AB	Adapter board
2	AS5000-MD8H-2	Diametric magnet, D8x2.5mm, NdFeB, Bomatec AG

1.2 Ordering Information

Ordering Code	Description
AS5x47U-TS_EK_AB	Adapter board assembled with AS5147U per default Assembly of AS5047U possible (pin compatible)

2 Board Description

The PCB can either be connected to an external microcontroller or to the USB I&P Box which is available on our webpage. (USB I&P Box)

P1 has to be populated with a 2x8 pin header and is required for power supply as well as SPI, ABI, UVW/PWM interfaces.

C1 (100 nF) and C2 (1 μ F) are capacitors to stabilize supply voltage.

R1 is an optional 0 ohm resistor with 0608 package. User can populate to connect 5V and 3V3 pin in case of 3V operation mode. As alternative both pins (5V and 3V3) on pin header P1 can be interconnected for 3V operation mode

Figure 3 :
AS5x47U Adapter Board

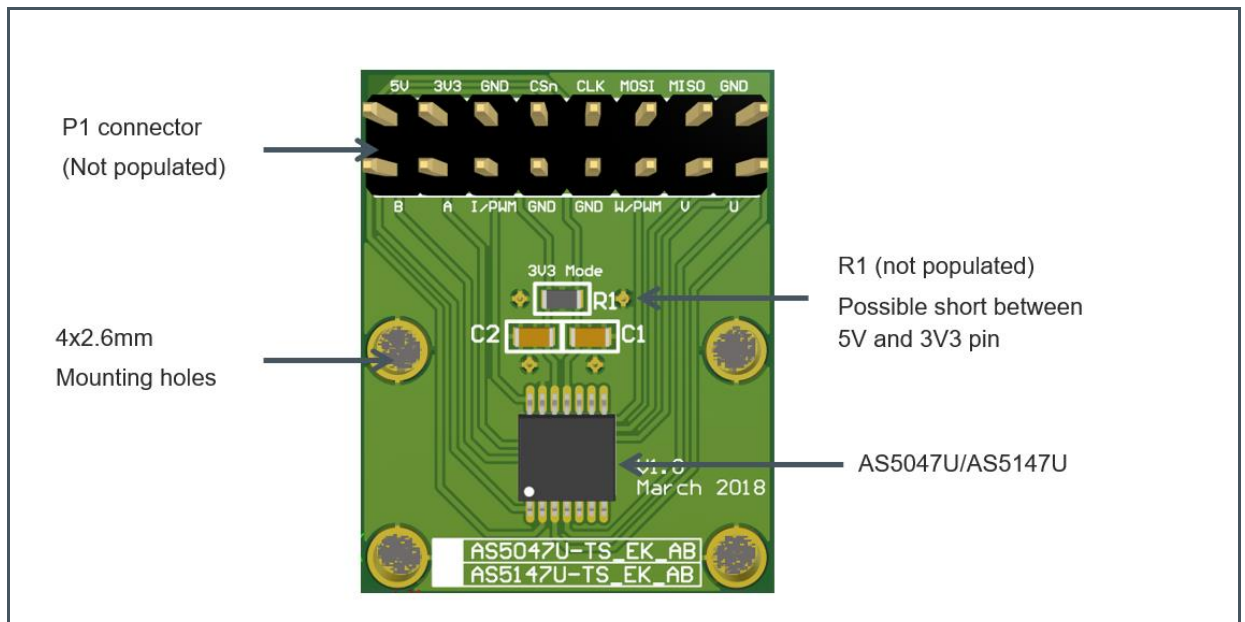

2.1 Mounting the AS5X47U Adapter Board

Figure 4 :
Mounting and Dimensions

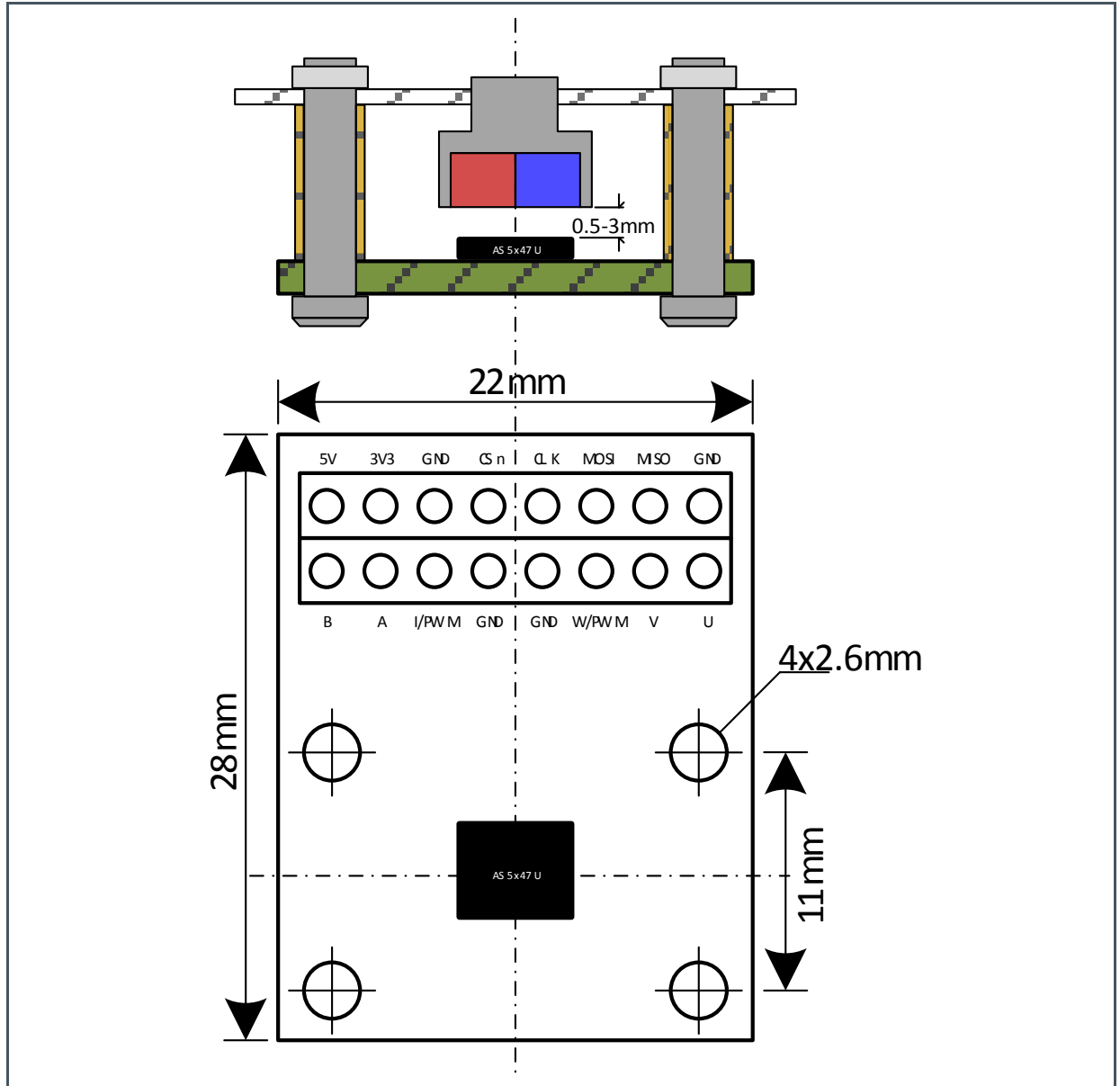

A diametric magnetized magnet must be placed over or under the AS5x47U sensor, and should be centered on the middle of the package with a tolerance of 0.5mm. The air gap between the magnet surface and the package should be maintained in the range 0.5mm to 3mm. The magnet holder must not be ferromagnetic. Materials as brass, copper, aluminum, stainless steel are the best choices to make this part.

3 Adapter Board and Pinout

Figure 5:
Adapter Board Pinout

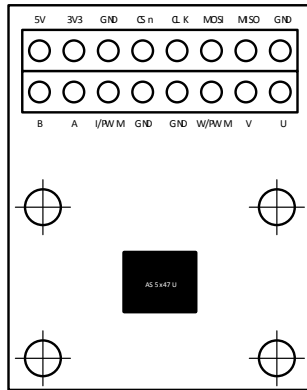

Figure 6:
Sensor Pinout

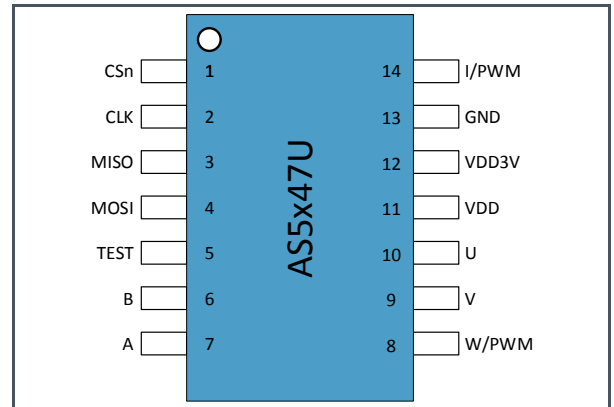

Figure 7:
Pinout Description

Pin# Board	Pin# AS5X47U	Symbol Board	Type	Description
P1 - 1	11	5V	Power supply	Positive supply voltage
P1 - 2	12	3V3	Power supply	3.3V LDO output
P1 - 3	13	GND	Power supply	Ground
P1 - 4	1	CSn	Digital input	SPI chip select (active low)
P1 - 5	2	CLK	Digital input	SPI clock
P1 - 6	4	MOSI	Digital input	SPI MOSI
P1 - 7	3	MISO	Digital output	SPI MISO
P1 - 8	13	GND	Power supply	Ground
P1 - 9	6	B	Digital output	Incremental signal B (quadrature)
P1 - 10	7	A	Digital output	Incremental signal A (quadrature)
P1 - 11	14	I/PWM	Digital output	Incremental signal I (index) or PWM
P1 - 12	13	GND	Power supply	Ground
P1 - 13	13	GND	Power supply	Ground
P1 - 14	8	W/PWM	Digital output	Commutation signal W or PWM
P1 - 15	9	V	Digital output	Commutation signal V
P1 - 16	10	U	Digital output	Commutation signal U

4 Operation Case

4.1 One Device SPI Mode, Bidirectional – 4 Wire, 3V3 Operation

To be able to write and read data from AS5x47U sensor, connect all 4 SPI lines to a SPI master device.

4.1.1 3V3 Operation

Supply 5V pin and 3V3 with 3.3V.

As an alternative, the user can assemble R1 with a 0 ohm bridge to short the 5V and VDD3V pin. In this case, only one of the supply pins need to be supplied with 3.3 V.

Digital output operates at 3.3V level.

Figure 8 :
One Device SPI Mode, Bidirectional – 4 Wire, 3V3 Operation

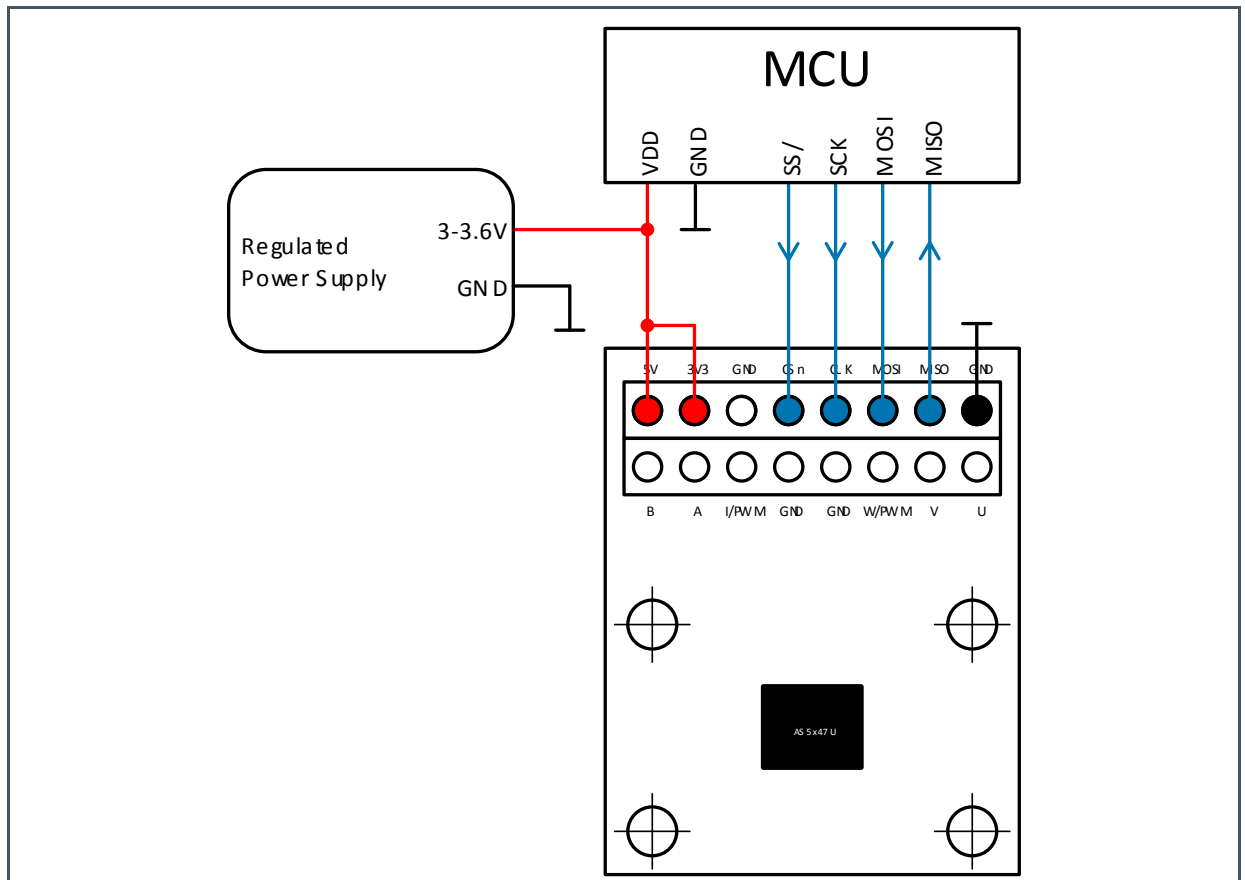

4.2 One Device SPI Mode, Bidirectional – 4 Wire, 5V Operation

To be able to write and read data from AS5x47U sensor, connect all 4 SPI lines to a SPI master device.

4.2.1 5V Operation

Supply 5V pin with 5V.

Leave 3V3 pin open. In this case, the 3V3 pin is the LDO output. No load allowed.

R1 must not be assembled!

Figure 9 :
One Device SPI Mode, Bidirectional – 4 Wire, 5V Operation

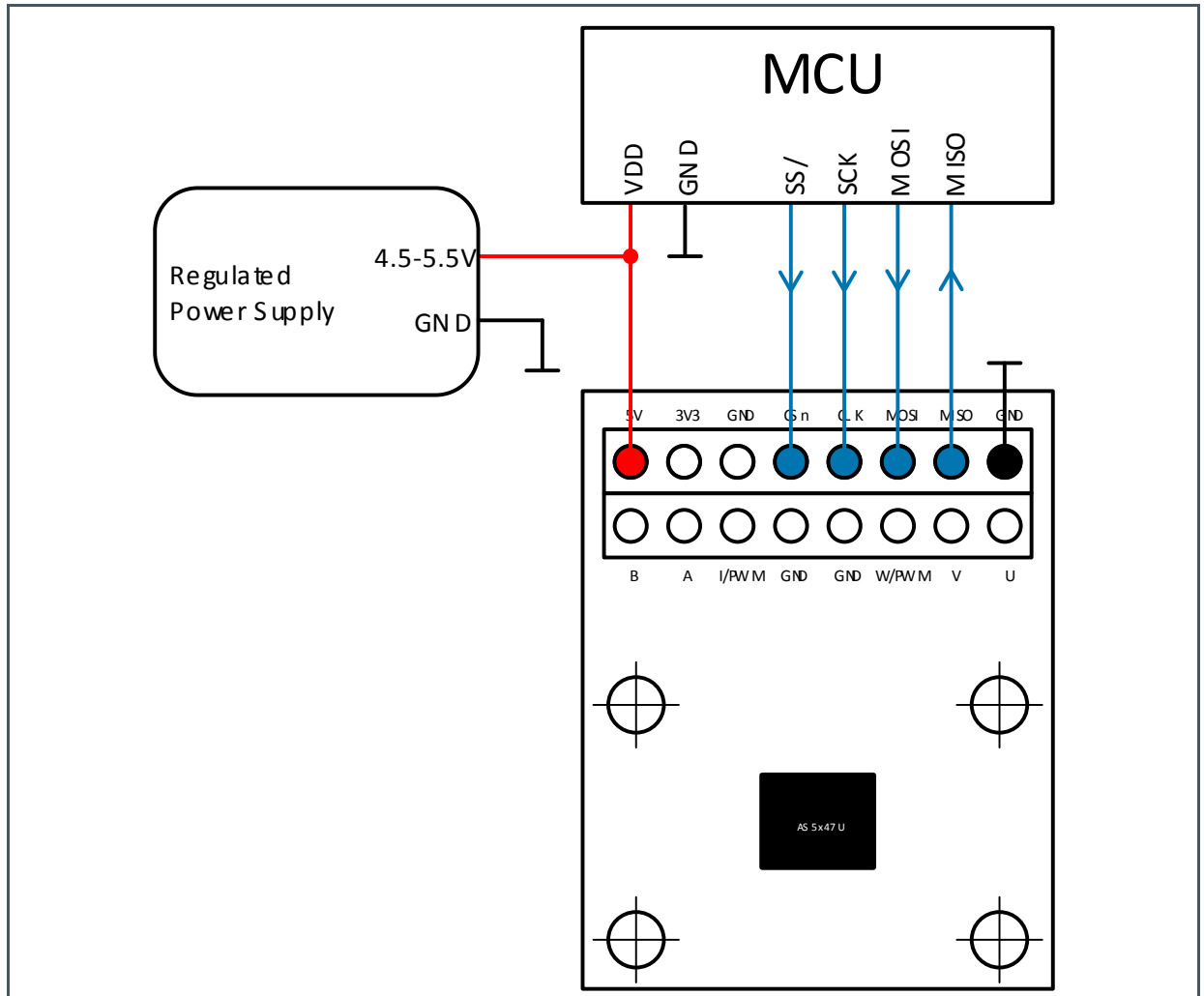

5 AS5x47U-TS_EK_AB Hardware

5.1 Schematics

Figure 10 :
Schematic

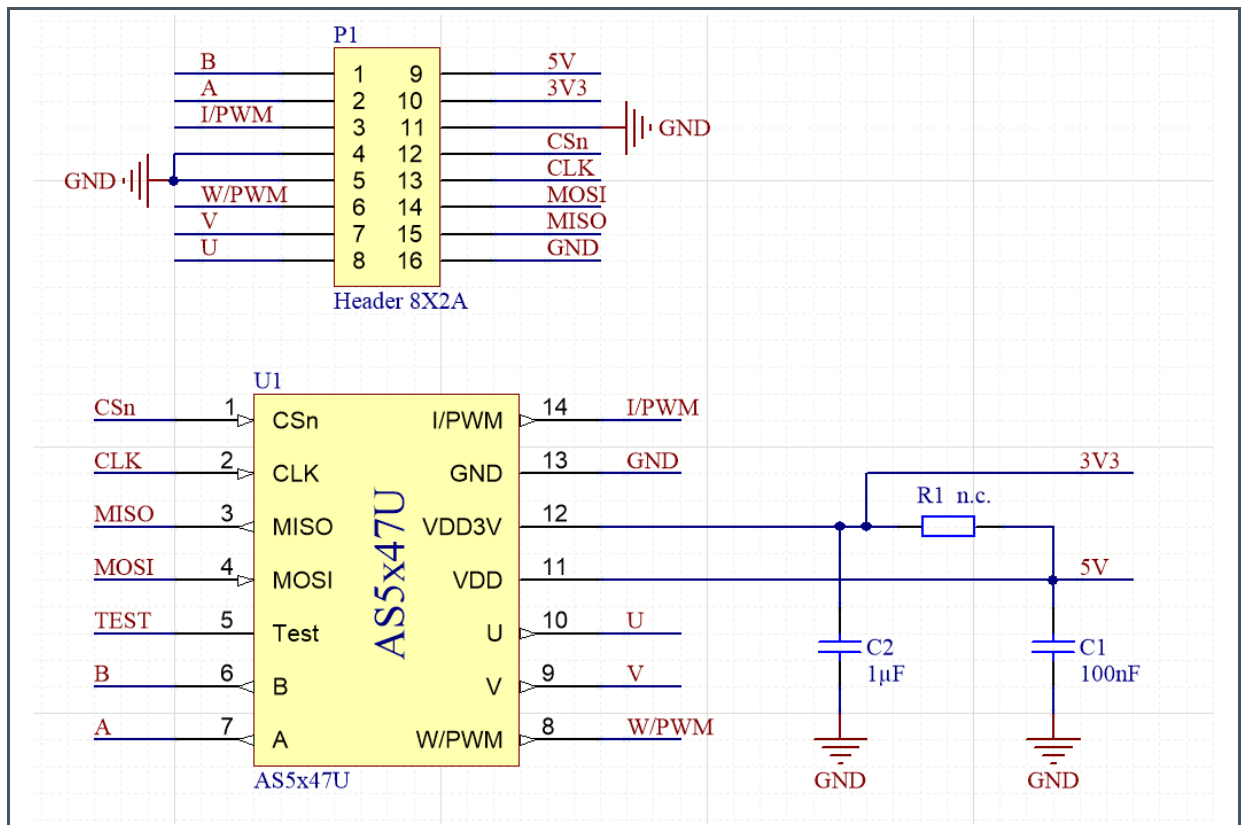

5.2 Layout

The adapter board is based on two copper layers. All signal and supply lines are placed on Top-Layer, Bottom-Layer is used as ground plane.

The four mounting holes are connected to GND as well.

Figure 11 :
PCB Layout

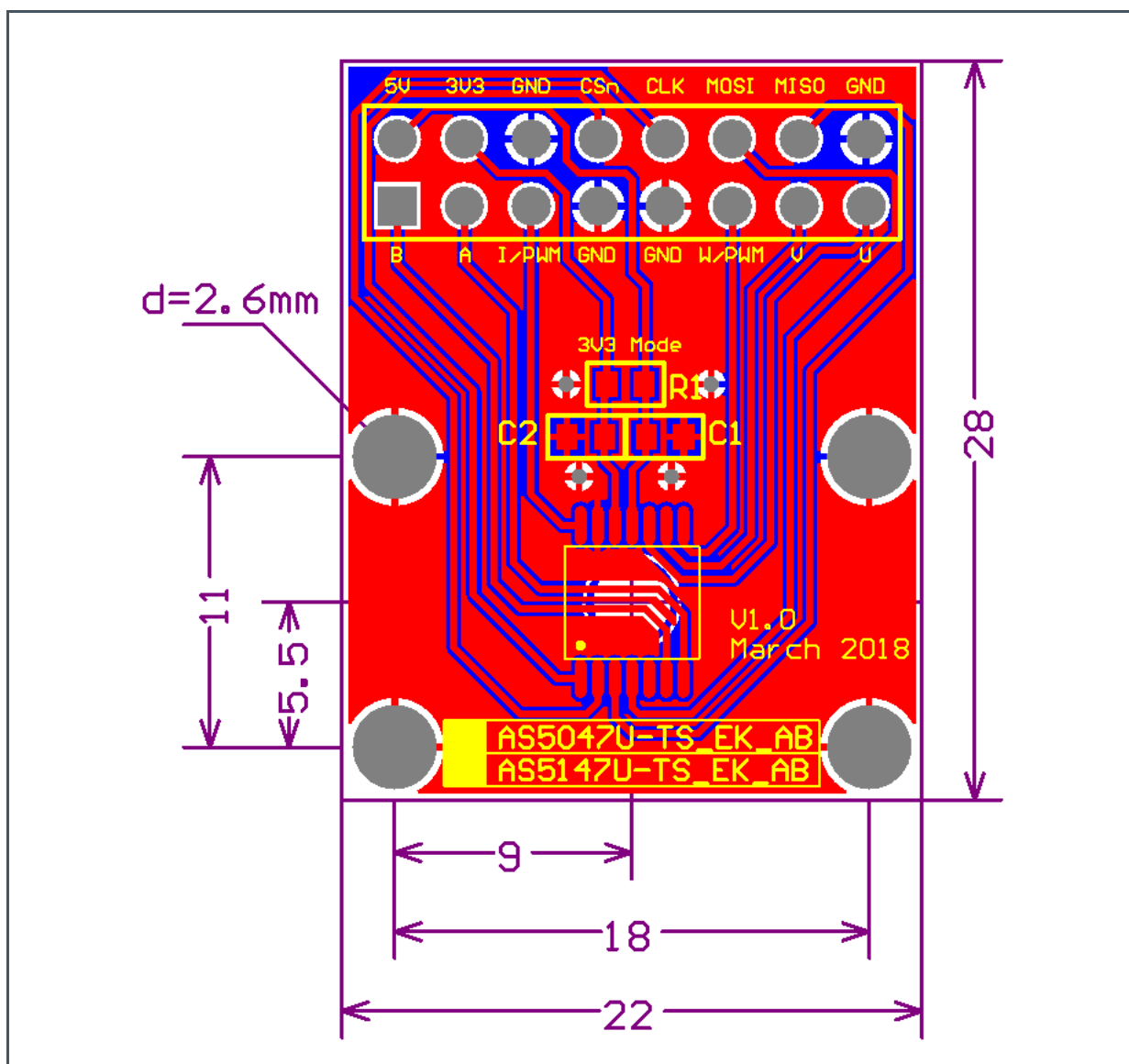

6 Revision Information

Changes from previous version to current revision v1-00	Page
---	------

Initial Version

- Page and figure numbers for the previous version may differ from page and figure numbers in the current revision.
- Correction of typographical errors is not explicitly mentioned.

7 Legal Information

Copyrights & Disclaimer

Copyright ams AG, Tobelbader Strasse 30, 8141 Premstaetten, Austria-Europe. Trademarks Registered. All rights reserved. The material herein may not be reproduced, adapted, merged, translated, stored, or used without the prior written consent of the copyright owner.

Demo Kits, Evaluation Kits and Reference Designs are provided to recipient on an "as is" basis for demonstration and evaluation purposes only and are not considered to be finished end-products intended and fit for general consumer use, commercial applications and applications with special requirements such as but not limited to medical equipment or automotive applications. Demo Kits, Evaluation Kits and Reference Designs have not been tested for compliance with electromagnetic compatibility (EMC) standards and directives, unless otherwise specified. Demo Kits, Evaluation Kits and Reference Designs shall be used by qualified personnel only.

ams AG reserves the right to change functionality and price of Demo Kits, Evaluation Kits and Reference Designs at any time and without notice.

Any express or implied warranties, including, but not limited to the implied warranties of merchantability and fitness for a particular purpose are disclaimed. Any claims and demands and any direct, indirect, incidental, special, exemplary or consequential damages arising from the inadequacy of the provided Demo Kits, Evaluation Kits and Reference Designs or incurred losses of any kind (e.g. loss of use, data or profits or business interruption however caused) as a consequence of their use are excluded.

ams AG shall not be liable to recipient or any third party for any damages, including but not limited to personal injury, property damage, loss of profits, loss of use, interruption of business or indirect, special, incidental or consequential damages, of any kind, in connection with or arising out of the furnishing, performance or use of the technical data herein. No obligation or liability to recipient or any third party shall arise or flow out of ams AG rendering of technical or other services.

RoHS Compliant & ams Green Statement

RoHS Compliant: The term RoHS compliant means that ams AG products fully comply with current RoHS directives. Our semiconductor products do not contain any chemicals for all 6 substance categories, including the requirement that lead not exceed 0.1% by weight in homogeneous materials. Where designed to be soldered at high temperatures, RoHS compliant products are suitable for use in specified lead-free processes.

ams Green (RoHS compliant and no Sb/Br): ams Green defines that in addition to RoHS compliance, our products are free of Bromine (Br) and Antimony (Sb) based flame retardants (Br or Sb do not exceed 0.1% by weight in homogeneous material).

Important Information: The information provided in this statement represents ams AG knowledge and belief as of the date that it is provided. ams AG bases its knowledge and belief on information provided by third parties, and makes no representation or warranty as to the accuracy of such information. Efforts are underway to better integrate information from third parties. ams AG has taken and continues to take reasonable steps to provide representative and accurate information but may not have conducted destructive testing or chemical analysis on incoming materials and chemicals. ams AG and ams AG suppliers consider certain information to be proprietary, and thus CAS numbers and other limited information may not be available for release.

Headquarters

ams AG
Tobelbader Strasse 30
8141 Premstaetten
Austria, Europe
Tel: +43 (0) 3136 500 0

Please visit our website at www.ams.com

Buy our products or get free samples online at www.ams.com/Products

Technical Support is available at www.ams.com/Technical-Support

Provide feedback about this document at www.ams.com/Document-Feedback

For sales offices, distributors and representatives go to www.ams.com/Contact

For further information and requests, e-mail us at ams_sales@ams.com