

PI2DBS32212

1.8 V, 1-to-32 Gbps 1-Lane 2:1 Mux/De-Mux Switch

Features

- 2 Differential-Channel, 2:1 Mux/DeMux
- Up to 32 Gbps for Applications including PCIe® 5.0, USB 3.0/3.1, USB 3.2 Gen 1x1/Gen 2x1, USB4 Gen 2x1/Gen 3x1, 10GE, Thunderbolt 3, SAS3.0 and CXL1.0
- Bi-directional Operation
- Low Bit-to-Bit Skew, 3 ps typ
- Low Channel-to-Channel Skew, 10 ps typ
- Low Insertion Loss: -0.9 dB@5 GHz, -1 dB@8 GHz, -2.7 dB@16 GHz
- Return Loss: -21.4 dB@5 GHz, -21 dB@8 GHz, -10.8 dB@16 GHz
- Low Power Consumption - 200 µA typ
- Supply Voltage: 1.8 V
- Industrial Temperature Range: -40 °C to 105 °C
- Totally Lead-Free & Fully RoHS Compliant (Notes 1 & 2)
- Halogen and Antimony Free. “Green” Device (Note 3)
- For automotive applications requiring specific change control (i.e. parts qualified to AEC-Q100/101/104/200, PPAP capable, and manufactured in IATF 16949 certified facilities), please [contact us](https://www.diodes.com/quality/product-definitions/) or your local Diodes representative.
- Packaging (Pb-free & Green):
 - 24-contact, X1QFN (XEB), 2.5x2.5mm

Application

Routing high speed differential signals including PCIe 5.0, USB 3.0/3.1, USB 3.2 Gen 1x1/Gen 2x1, USB4 Gen 2x1/Gen 3x1, 10GE, Thunderbolt 3, SAS3.0 and CXL1.0 signals.

Description

The DIODES™ PI2DBS32212 is a generic analog high speed passive mux/demux. The configuration is 4-to-2 differential-channel, and data rate is up to 32 Gbps. Based on an unique design technique, Diodes has been able to optimize dynamic electrical characteristics of the device, including low insertion loss, crosstalk and return loss. The device allows high-speed switching with minimum attenuation to the signal and suitable for multiple signal types including PCIe 5.0, USB 3.0/3.1, USB 3.2 Gen 1x1/Gen 2x1, USB4 Gen 2x1/Gen 3x1, 10GE, Thunderbolt 3, SAS3.0 and CXL1.0 signals.

Block Diagram

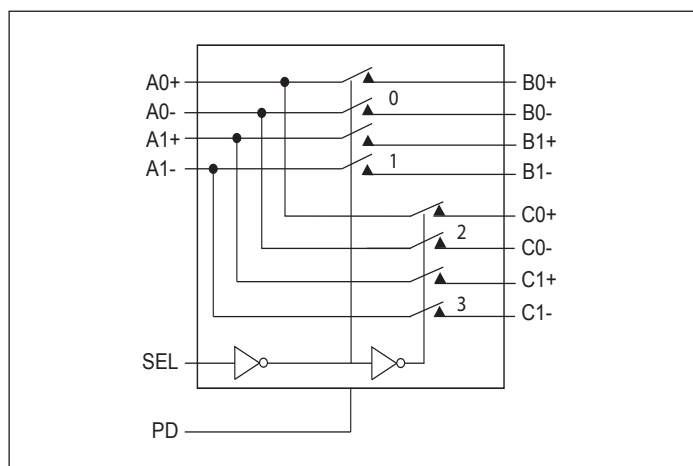

Truth Table

Function	SEL	PD
A _N to B _N	L	L
A _N to C _N	H	L
All Switches Hi-z	x	H

Notes:

1. No purposely added lead. Fully EU Directive 2002/95/EC (RoHS), 2011/65/EU (RoHS 2) & 2015/863/EU (RoHS 3) compliant.
2. See <https://www.diodes.com/quality/lead-free/> for more information about Diodes Incorporated’s definitions of Halogen- and Antimony-free, “Green” and Lead-free.
3. Halogen- and Antimony-free “Green” products are defined as those which contain <900ppm bromine, <900ppm chlorine (<1500ppm total Br + Cl) and <1000ppm antimony compounds.

DIODES is a trademark of Diodes Incorporated in the United States and other countries.

The Diodes logo is a registered trademark of Diodes Incorporated in the United States and other countries.

PCI Express® and PCIe® are trademarks or registered trademarks and/or service marks of PCI-SIG Corporation.

Pin Configuration

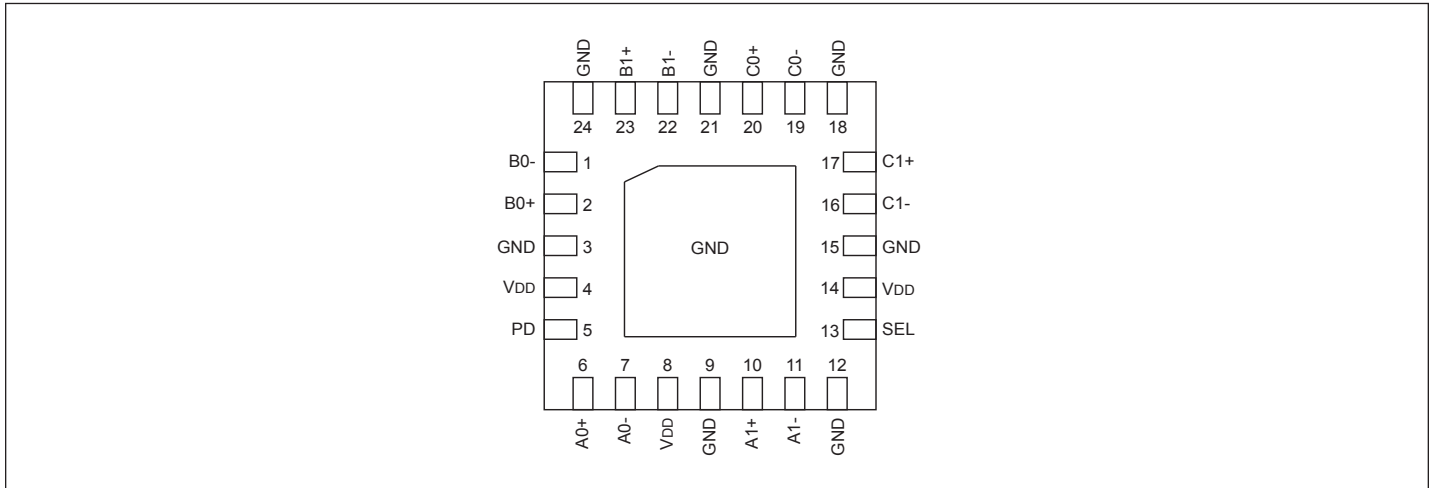

Pin Description

Pin#	Pin Name	I/O	Description
6	A0+	I/O	Signal I/O, Channel 0, Port A, 100K pull-down
7	A0-		
10	A1+	I/O	Signal I/O, Channel 1, Port A, 100K pull-down
11	A1-		
2	B0+	I/O	Signal I/O, Channel 0, Port B
1	B0-		
23	B1+	I/O	Signal I/O, Channel 1, Port B
22	B1-		
20	C0+	I/O	Signal I/O, Channel 0, Port C
19	C0-		
17	C1+	I/O	Signal I/O, Channel 1, Port C
16	C1-		
13	SEL	I	Operation mode Select (when SEL=0: A→B, when SEL=1: A→C)
5	PD	I	PD = 1, Power down is enabled. Please see Truth Table
4, 8, 14	V _{DD}	Pwr	1.8V ±10% Positive Supply Voltage
3, 9, 12, 15, 18, 21, 24, center pad	GND	Pwr	Power ground

Maximum Ratings

(Above which useful life may be impaired. For user guidelines, not tested.)

Storage Temperature	-65°C to +150°C
Supply Voltage to Ground Potential	-0.5V to +2.1V
Channel DC Input Voltage	-0.5V to 1.5V
DC Output Current	120mA
Power Dissipation	0.5W
Control Logic DC Input Voltage	-0.5V
Maximum Stress Voltage (MSV).....	3.8V
ESD (HBM)	850V

Note:

Stresses greater than those listed under MAXIMUM RATINGS may cause permanent damage to the device. This is a stress rating only and functional operation of the device at these or any other conditions above those indicated in the operational sections of this specification is not implied. Exposure to absolute maximum rating conditions for extended periods may affect reliability.

Electrical Characteristics

Recommended Operating Conditions

Symbol	Parameter	Conditions	Min.	Typ.	Max.	Units
V _{DD}	1.8V Power Supply		1.6	1.8	2.0	V
I _{DD}	Current consumption in normal operation	SEL = GND or V _{DD} , PD = Low		0.2	0.4	mA
I _{DDQ}	Current consumption when all switches are disabled	V _{DD} = 1.8V, PD = High		0.05		mA
P _{DD}	Total Power from VDD 1.8V supply	Control pins = GND or V _{DD}		0.5		mW
P _{DDQ}	Power consumption when all switches are disabled	V _{DD} = 1.8V, PD = High		0.1		mW
T _A	Operating temperature range		-40		105	°C

DC Electrical Characteristics for Switching over Operating Range

Parameters	Description	Test Conditions ⁽¹⁾	Min.	Typ. ⁽¹⁾	Max.	Units
V _{IH} - cntrl signals	Input HIGH Voltage for SEL and PD	V _{DD} = 1.8V	1.4			V
V _{IL} - cntrl signals	Input LOW Voltage for SEL and PD	V _{DD} = 1.8V			0.4	
V _{IK}	Clamp Diode Voltage	V _{DD} = Max., I _{input} = -18mA		-0.7	-1.2	
I _{IH}	Input HIGH Current for SEL and PD	V _{DD} = Max., V _{input} = V _{DD}	-80		+80	µA
I _{IL}	Input LOW Current for SEL and PD	V _{DD} = Max., V _{input} = 0V	-10		+10	
I _{OZH}	HighZ HIGH Current, switch I/O pins	V _{DD} = 1.8V., V _{input} = 1.2V	-20		+20	µA
I _{OZL}	HighZ LOW Current, switch I/O pins	V _{DD} = Max., V _{input} = 0V	-10		+10	µA
V _p	Max voltage pass through tolerance analog switches (See Test Circuit)	V _{DD} = 1.8V, I _{PASS} = 10mA		1		V
V _{IN}	Analog Signal to input of switch			1.1	1.2	V

Note:

1. Typical values are at V_{DD} = 1.8V, T_A = 25°C ambient and maximum loading.

Dynamic Electrical Characteristics

Parameter	Description	Test Conditions	Min.	Typ. ⁽¹⁾	Max.	Units
DDIL	Differential Insertion Loss	f=2.5GHz f=4.0GHz f=5.0GHz f=8.0GHz f=10.0GHz f=16.0GHz		-0.9 -0.9 -0.9 -1.0 -1.0 -2.7		dB
DDRL	Differential Return Loss	f= 2.5GHz f= 4.0GHz f= 5.0GHz f= 8.0GHz f=10.0GHz f=16.0GHz		-22.0 -21.9 -21.4 -21.0 -20.5 -10.8		dB
DDOI	Differential OFF Isolation	f= 2.5GHz f= 4.0GHz f= 5.0GHz f= 8.0GHz f=10.0GHz f=16.0GHz		-29.0 -23.0 -23.0 -19.0 -17.0 -15.0		dB
DDXT	Differential Crosstalk	f= 2.5GHz f= 4.0GHz f= 5.0GHz f=8.0GHz f=10.0GHz f=16.0GHz		-44.7 -41.4 -40.0 -40.0 -36.8 -30.0		dB

Switching Characteristics

Symbol	Parameter	Test Conditions	Min.	Typ.	Max.	Units
t _{PZH} , t _{PZL}	Line Enable Time - SEL to A _N , B _N , C _N			200	350	ns
t _{PHZ} , t _{PLZ}	Line Disable Time - SEL to A _N , B _N , C _N			200	350	ns
t _{PLH}	Propagation Delay, LOW to HIGH				50	ps
t _{PHL}	Propagation Delay, HIGH to LOW				50	ps
t _{b-b}	Bit-to-bit skew within the same differential pair			3	10	ps
t _{ch-ch}	Channel-to-channel skew			10	20	ps

PI2DBS32212

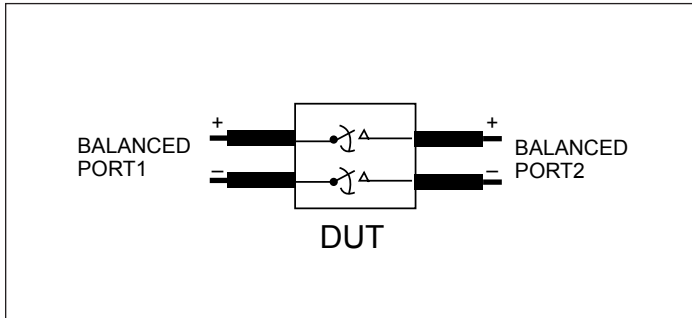

Diff. Insertion Loss and Return Loss Test Circuit

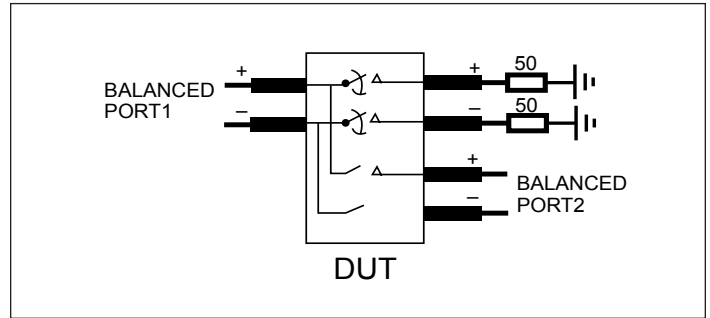

Diff. Off Isolation Test Circuit

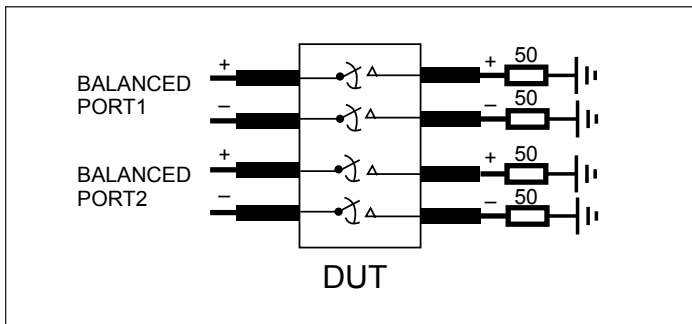

Diff. Near End Xtalk Test Circuit

Test Circuit for Electrical Characteristics⁽¹⁻⁵⁾

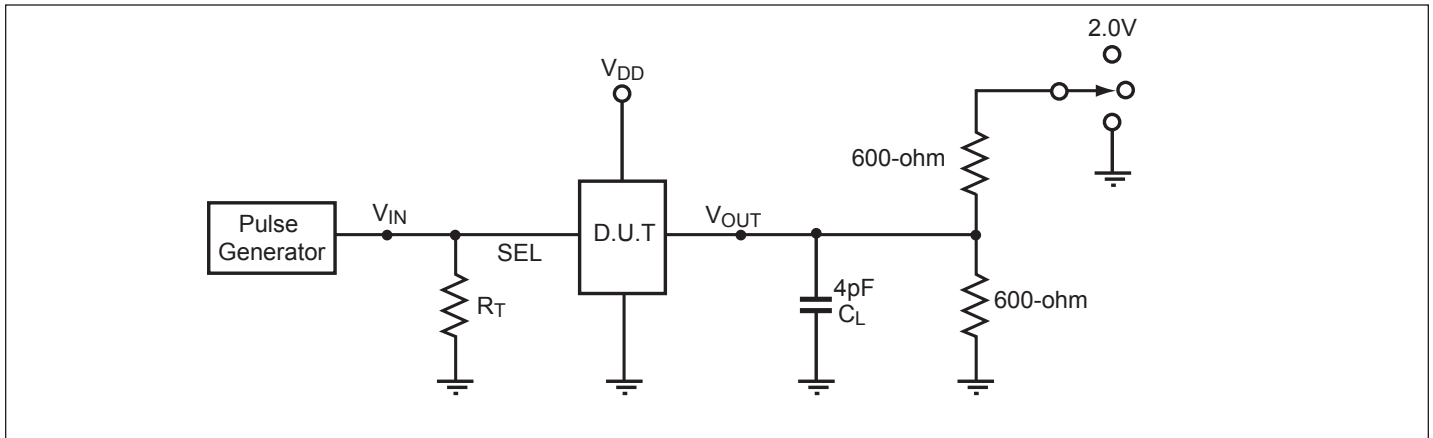

Notes:

1. C_L = Load capacitance: includes jig and probe capacitance.
2. R_T = Termination resistance: should be equal to Z_{OUT} of the Pulse Generator
3. Output 1 is for an output with internal conditions such that the output is low except when disabled by the output control.
output 2 is for an output with internal conditions such that the output is high except when disabled by the output control.
4. All input impulses are supplied by generators having the following characteristics: $PRR \leq \text{MHz}$, $Z_O = 50\Omega$, $t_R \leq 2.5\text{ns}$, $t_F \leq 2.5\text{ns}$.
5. The outputs are measured one at a time with one transition per measurement.

Switch Position

Test	Switch
t_{PLZ}, t_{PZL}	2.0V
t_{PHZ}, t_{PZH}	GND

Switching Waveforms

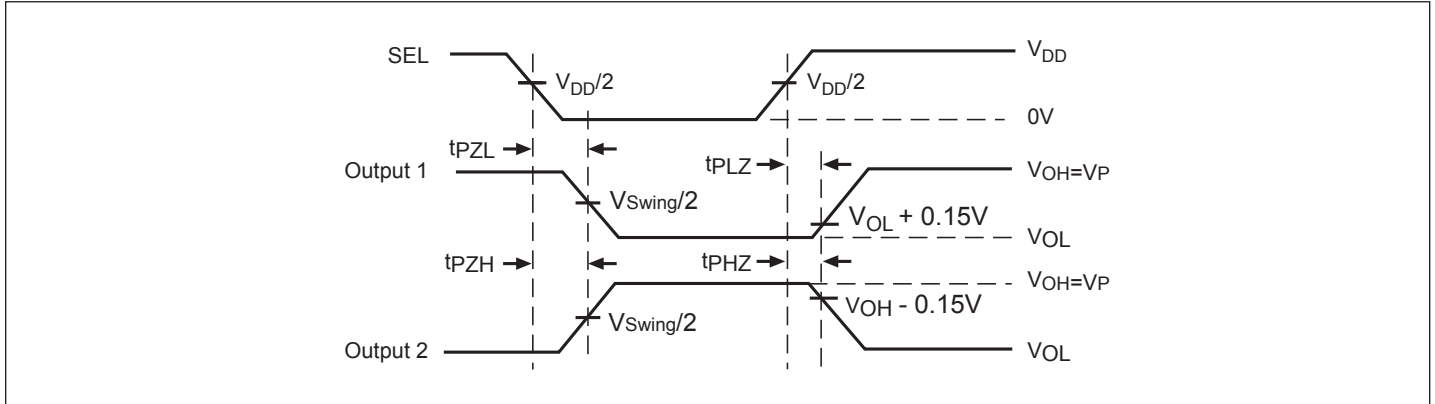

Voltage Waveforms Enable and Disable Times

Test Circuit for Propagation Delay

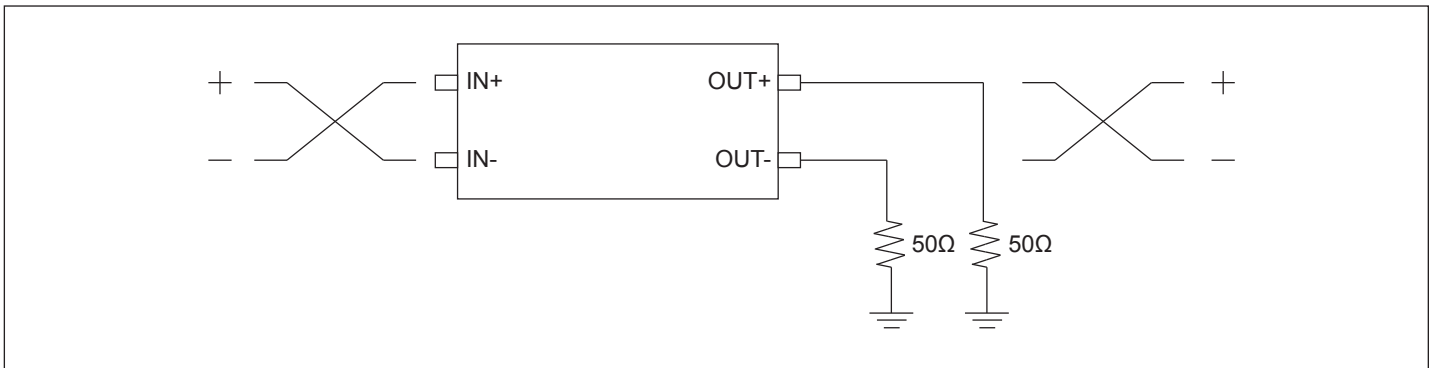

Differential Input/Output Signal Waveform

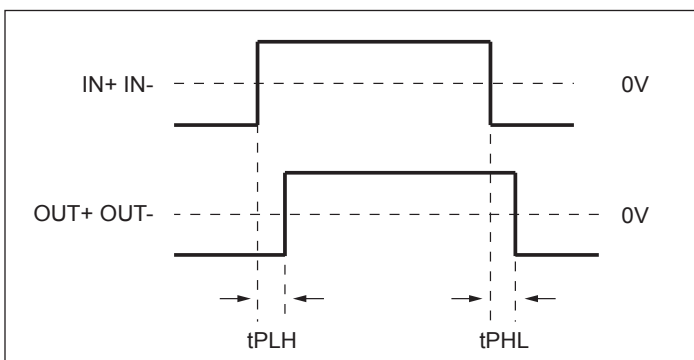

Test Circuit for SEL Switching Time

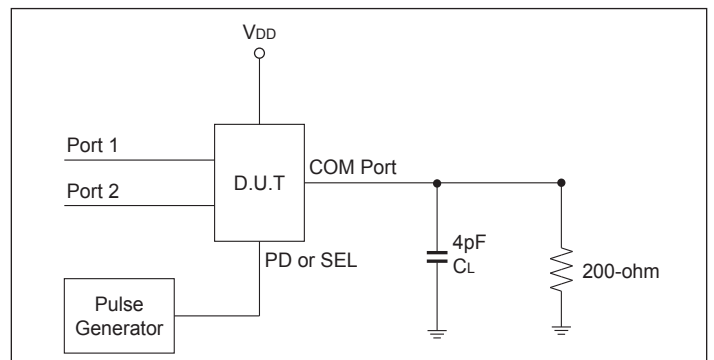

Test Circuit for Max Voltage Pass through

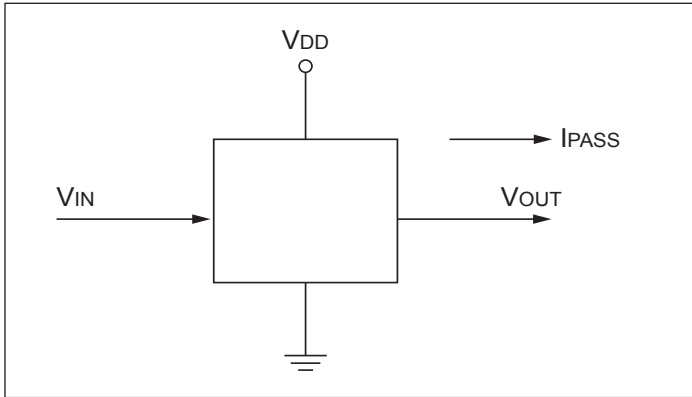

Part Marking

S3221
2XEBE
*YXX
○

Pericom Product Family
Device/Pkg Type

*: Option Code for Top Mark
Y: One Character Shortened Date Code
1st X: Assembly Code
2nd X: Fab Code
Note: Date Code per MA-1251

Packaging Mechanical: 24-X1QFN (XEB)

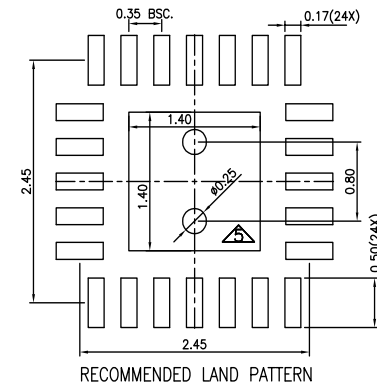
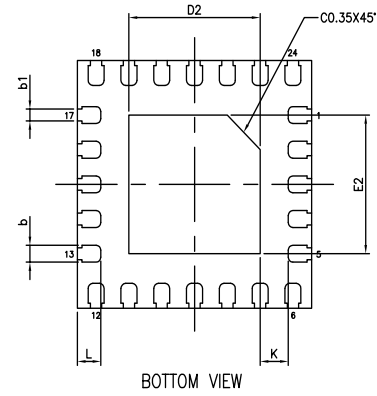
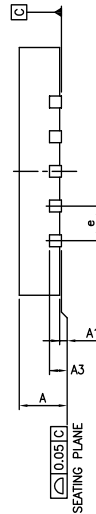
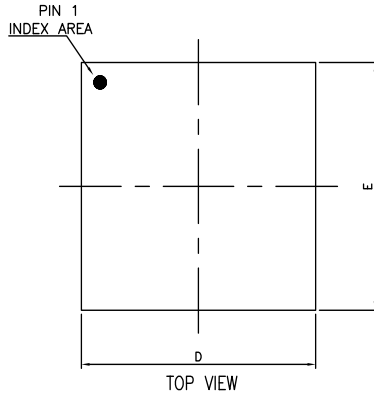

SYMBOLS	MIN.	NOM.	MAX.
A	0.40	0.45	0.50
A1	0.00	0.02	0.05
A3	0.127 REF.		
b	0.12	0.17	0.22
b1	0.07	0.12	0.17
D	2.45	2.50	2.55
E	2.45	2.50	2.55
e	0.35 BSC		
L	0.20	0.25	0.30
K	0.20	—	—
D2	1.35	1.40	1.45
E2	1.35	1.40	1.45

NOTE :

1. ALL DIMENSIONS ARE IN mm. ANGLES IN DEGREES.
2. COPLANARITY APPLIES TO THE EXPOSED THERMAL PAD AS WELL AS THE TERMINALS.
3. REFER JEDEC MO-288
4. RECOMMENDED LAND PATTERN IS FOR REFERENCE ONLY.
5. THERMAL PAD SOLDERING AREA

DIODES PERICOM INCORPORATED	DATE: 06/26/19
DESCRIPTION: 24-Contact, Extra Thin Fine Pitch QFN, X1QFN	
PACKAGE CODE: XEB (XEB24)	
DOCUMENT CONTROL #: PD-2243	REVISION: --

20-0457

For latest package info.

please check: <http://www.diodes.com/design/support/packaging/pericom-packaging/packaging-mechanicals-and-thermal-characteristics/>

Ordering Information

Ordering Number	Package Code	Package Description
PI2DBS32212XEBEX	XEB	24-Contact, Extra Thin Fine Pitch QFN (X1QFN)

Notes:

1. No purposely added lead. Fully EU Directive 2002/95/EC (RoHS), 2011/65/EU (RoHS 2) & 2015/863/EU (RoHS 3) compliant.
2. See <https://www.diodes.com/quality/lead-free/> for more information about Diodes Incorporated's definitions of Halogen- and Antimony-free, "Green" and Lead-free.
3. Halogen- and Antimony-free "Green" products are defined as those which contain <900ppm bromine, <900ppm chlorine (<1500ppm total Br + Cl) and <1000ppm antimony compounds.
4. E = Pb-free and Green
5. X suffix = Tape/Reel

IMPORTANT NOTICE

1. DIODES INCORPORATED AND ITS SUBSIDIARIES (“DIODES”) MAKE NO WARRANTY OF ANY KIND, EXPRESS OR IMPLIED, WITH REGARDS TO ANY INFORMATION CONTAINED IN THIS DOCUMENT, INCLUDING, BUT NOT LIMITED TO, THE IMPLIED WARRANTIES OF MERCHANTABILITY, FITNESS FOR A PARTICULAR PURPOSE OR NON-INFRINGEMENT OF THIRD PARTY INTELLECTUAL PROPERTY RIGHTS (AND THEIR EQUIVALENTS UNDER THE LAWS OF ANY JURISDICTION).

2. The Information contained herein is for informational purpose only and is provided only to illustrate the operation of Diodes products described herein and application examples. Diodes does not assume any liability arising out of the application or use of this document or any product described herein. This document is intended for skilled and technically trained engineering customers and users who design with Diodes products. Diodes products may be used to facilitate safety-related applications; however, in all instances customers and users are responsible for (a) selecting the appropriate Diodes products for their applications, (b) evaluating the suitability of the Diodes products for their intended applications, (c) ensuring their applications, which incorporate Diodes products, comply the applicable legal and regulatory requirements as well as safety and functional-safety related standards, and (d) ensuring they design with appropriate safeguards (including testing, validation, quality control techniques, redundancy, malfunction prevention, and appropriate treatment for aging degradation) to minimize the risks associated with their applications.

3. Diodes assumes no liability for any application-related information, support, assistance or feedback that may be provided by Diodes from time to time. Any customer or user of this document or products described herein will assume all risks and liabilities associated with such use, and will hold Diodes and all companies whose products are represented herein or on Diodes' websites, harmless against all damages and liabilities.

4. Products described herein may be covered by one or more United States, international or foreign patents and pending patent applications. Product names and markings noted herein may also be covered by one or more United States, international or foreign trademarks and trademark applications. Diodes does not convey any license under any of its intellectual property rights or the rights of any third parties (including third parties whose products and services may be described in this document or on Diodes' website) under this document.

5. Diodes products are provided subject to Diodes' Standard Terms and Conditions of Sale (<https://www.diodes.com/about/company/terms-and-conditions/terms-and-conditions-of-sales/>) or other applicable terms. This document does not alter or expand the applicable warranties provided by Diodes. Diodes does not warrant or accept any liability whatsoever in respect of any products purchased through unauthorized sales channel.

6. Diodes products and technology may not be used for or incorporated into any products or systems whose manufacture, use or sale is prohibited under any applicable laws and regulations. Should customers or users use Diodes products in contravention of any applicable laws or regulations, or for any unintended or unauthorized application, customers and users will (a) be solely responsible for any damages, losses or penalties arising in connection therewith or as a result thereof, and (b) indemnify and hold Diodes and its representatives and agents harmless against any and all claims, damages, expenses, and attorney fees arising out of, directly or indirectly, any claim relating to any noncompliance with the applicable laws and regulations, as well as any unintended or unauthorized application.

7. While efforts have been made to ensure the information contained in this document is accurate, complete and current, it may contain technical inaccuracies, omissions and typographical errors. Diodes does not warrant that information contained in this document is error-free and Diodes is under no obligation to update or otherwise correct this information. Notwithstanding the foregoing, Diodes reserves the right to make modifications, enhancements, improvements, corrections or other changes without further notice to this document and any product described herein. This document is written in English but may be translated into multiple languages for reference. Only the English version of this document is the final and determinative format released by Diodes.

8. Any unauthorized copying, modification, distribution, transmission, display or other use of this document (or any portion hereof) is prohibited. Diodes assumes no responsibility for any losses incurred by the customers or users or any third parties arising from any such unauthorized use.

Copyright © 2022 Diodes Incorporated

www.diodes.com

Mouser Electronics

Authorized Distributor

Click to View Pricing, Inventory, Delivery & Lifecycle Information:

[Diodes Incorporated:](#)

[PI2DBS32212XEBEX](#)