



DIN power female connector



General information

Design	IEC 60603-2	types: D, E female
No. of contacts	max. 48	
Contact spacing	5,08 mm	
Test voltage	1550V	
Contact resistance	max. 15mOhm	
Insulation resistance	min. 10 ⁹ Ohm	
Working current	6 A at 20°C (see derating diagram)	
Temperature range	-55°C ... +125°C -40°C ... +105°C for press-in connectors (due to limitations of PCB-material)	
Termination technology	solder pins, solder lugs, wirewrap, press-in	
Clearance	min. 3,0 mm	
Creepage	min. 3,0 mm	
Insertion and withdrawal force	32pole max. 50N 48pole max. 75N	
Mating cycles	acc. to performance level, see table below	
UL file	E102079	
RoHS - compliant	Yes	
Leadfree	Yes	
Hot plugging	No	

Insulator material

Material	PBT (thermoplastics, glass fiber reinforcement 30%)	
Color	RAL 7032 (grey)	
UL classification	UL 94-V0	
Material group acc. IEC 60664-1	IIIa (175 ≤ CTI < 400)	
NFF classification	I3, F4	

Contact material

Contact material	Copper alloy	
Plating termination zone	Sn over Ni for solder pins & lugs	Ni for wirewrap & press-in
Plating contact zone	acc. to performance level, see table below	

performance level	mating cycles		plating contact zone	
	acc. to IEC 60603-2	complementary acc. to IEC 60603-2	solder pins, solder lugs, wire wrap	press-in
1	500		<i>Au over PdNi over Ni</i>	<i>Au over Ni</i>
2	400		<i>Au over PdNi over Ni</i>	<i>Au over Ni</i>
3	50		<i>Au over PdNi over Ni</i>	<i>Au over Ni</i>
Au70		500	min. 1,60µm (70µinch) Au over Ni	
Au90		500	min. 2,00µm (90µinch) Au over Ni	

Standard plating options highlighted in *italic*, other plating options are available on request.

Cross section of solder pins

Cross section of wirewrap posts

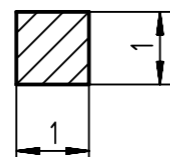
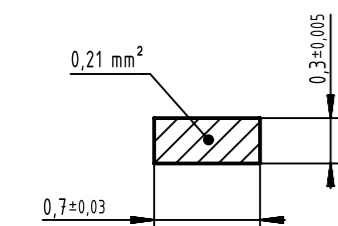

Recommended configuration of plated through holes for press-in termination

In addition to the hot-air-level (HAL), other PCB surfaces are getting more important. Due to their different properties - such as mechanical strength and coefficient of friction - we recommend the following configuration of PCB through holes.

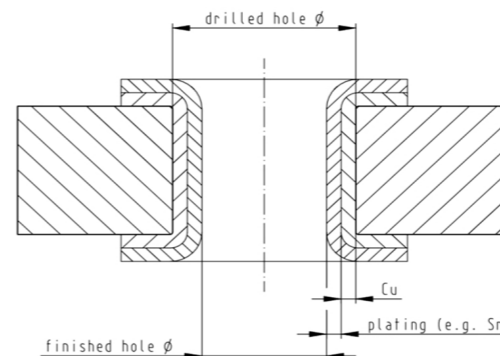

Tin plated PCB (HAL) acc. to EN 60352-5	Drilled hole Ø	1,15±0,025 mm
	Cu	min. 25 µm
	Sn	max. 15 µm
Chemical tin plated PCB	Drilled hole Ø	1,15±0,025 mm
	Cu	min. 25 µm
	Sn	min. 0,8µm
Gold /Nickel plated PCB	Drilled hole Ø	1,15±0,025 mm
	Cu	min. 25 µm
	Ni	3 - 7 µm
Silver plated PCB	Drilled hole Ø	1,15±0,025 mm
	Cu	min. 25 µm
	Ag	0,1 - 0,3 µm
Copper plated PCB (OSP)	Drilled hole Ø	1,15±0,025 mm
	Cu	min. 25 µm
	plated hole Ø	1,00 - 1,10 mm

Assembly instructions

It is highly recommended to use HARTING press-in tools to ensure a reliable press-in process. Please refer to the catalogue for tools, machines and further information about the press-in process.

Soldering instructions

The connectors should be protected when being soldered in a dip, flow or film soldering baths. Otherwise, they might become contaminated as a result of soldering operations or deformed as a result of overheating.

(1) For prototypes and short runs protect the connectors with an industrial adhesive tape, e.g. Tesaband 4331 (www.tesa.de). Cover the underside of the connector moulding and the adjacent parts of the pcb as well as the open sides of the connector. This will prevent heat and gases of the soldering apparatus from damaging the connector. About 140 + 5 mm of the tape should suffice.

(2) For large series a jig is recommended. Its protective cover with a fast action mechanical locking device shields the connectors from gas and heat generated by the soldering apparatus. As an additional protection a foil can be used for covering the parts that should not be soldered.

Derating diagram acc. to IEC 60512-5 (Current carrying capacity)

The current carrying capacity is limited by maximum temperature of materials for inserts and contacts including terminals.

The current capacity curve is valid for continuous, non interrupted current loaded contacts of connectors when simultaneous power on all contacts is given, without exceeding the maximum temperature.

Control and test procedures according to DIN IEC 60512-5

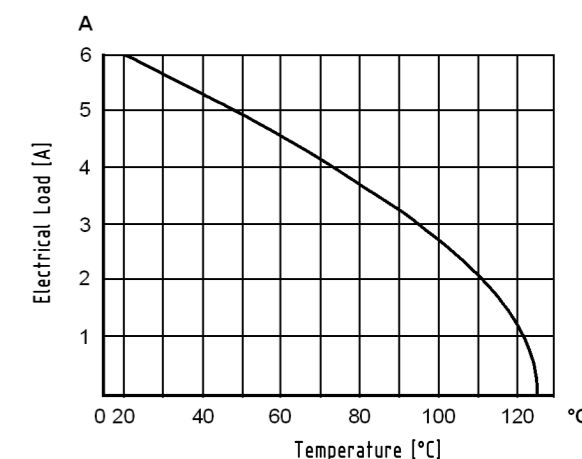

All Dimensions in mm Original Size DIN A3		Scale 1:1	Free size tol.		Ref. Sub.
All rights reserved Department EL PD		Created by LEHNERT	Inspected by DAHMS	Standardisation HOFFMANN	Date 2018-06-27
HARTING Electronics GmbH D-32339 Espelkamp		Title DIN Power female connector			State Final Release
		Type DS	Number 0904210001		Doc-Key / ECM-Nr. 100580520/UGD/000/C 500000131805
					Rev. C Page 1/1

Mouser Electronics

Authorized Distributor

Click to View Pricing, Inventory, Delivery & Lifecycle Information:

HARTING:

[09058486831](#) [09042322821](#) [09042322832](#) [09042326823](#) [09042326832](#) [09042327832](#) [09047326831](#)
[09052482821](#) [09052482831](#) [09052482832](#) [09052486821](#) [09052487821](#) [09057482831](#) [09057486831](#) [09042326831](#)
[09052486831](#) [09042322823](#) [09052486832](#) [09052486851](#) [09042322831](#) [09052486823](#) [09052482851](#)
[09052487832](#) [09042327831](#) [09047326821](#) [09047326832](#) [09052482854](#) [09042327823](#) [09042326821](#) [09042327821](#)
[09052482823](#) [09043326831](#) [09052487823](#) [09053486831](#)