

# KA7500B

## SMPS Controller

### Features

- Internal Regulator Provides a Stable 5V Reference Supply Trimmed to 5%
- Uncommitted Output TR for 200mA Sink or Source Current
- Output Control For Push-Pull or Single Ended Operation
- Variable Duty Cycle By Dead Time Control (Pin 4) Complete PWM Control Circuit
- On-Chip Oscillator With Master or Slave Operation
- Internal Circuit Prohibits Double Pulse at Either Output

### Description

The KA7500B is used for the control circuit of the PWM switching regulator. The KA7500B consists of 5V reference voltage circuit, two error amplifiers, a flip flop, an output control circuit, a PWM comparator, a dead time comparator and an oscillator. This device can be operated in the switching frequency of 1kHz to 300kHz.



### Internal Block Diagram

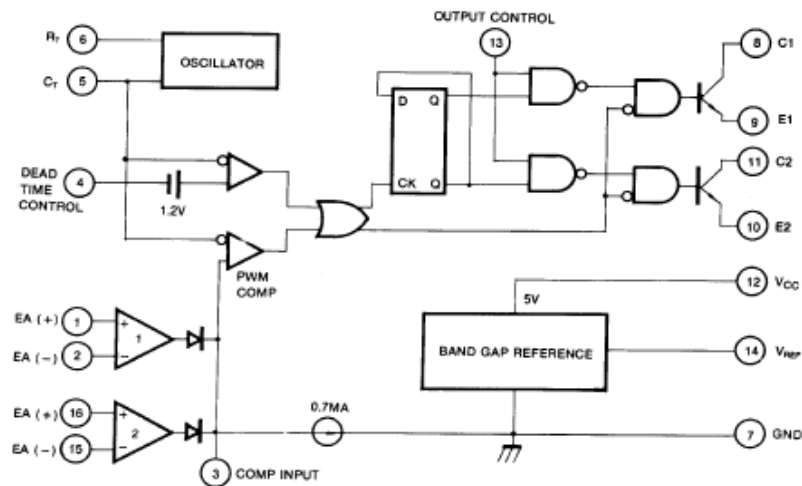

Rev. 1.0.0

---

**Absolute Maximum Ratings**

| Parameter                     | Symbol | Value                         | Unit |
|-------------------------------|--------|-------------------------------|------|
| Supply Voltage                | VCC    | 42                            | V    |
| Collector Supply Voltage      | VC     | 42                            | V    |
| Output Current                | IO     | 250                           | mA   |
| Amplifier Input Voltage       | VIN    | VCC +0.3                      | V    |
| Power Dissipation (TA = 25°C) | PD     | 1 (KA7500B)<br>0.9 (KA7500BD) | W    |
| Operating Temperature Range   | TOPR   | 0 ~ +70                       | °C   |
| Storage Temperature Range     | TSTG   | -65 ~ +150                    | °C   |

## Electrical Characteristics

( $V_{CC} = 20V$ ,  $f = 10kHz$ ,  $T_A = 0^{\circ}C$  to  $+70^{\circ}C$ , unless otherwise specified)

| Parameter                                   | Symbol        | Conditions   | Min. | Typ. | Max.     | Unit           |
|---|---------------|--|------|------|----------|----------------|
| <b>REFERENCE SECTION</b>                    |               |  |      |      |          |                |
| Reference Output Voltage                    | $V_{REF}$     | $I_{REF} = 1mA$                                    | 4.75 | 5.0  | 5.25     | V              |
| Line Regulation                             | $V_{REF}$     | $V_{CC} = 7V$ to $40V$                             | -    | 2.0  | 25       | mV             |
| Temperature Coefficient of $V_{REF}$        | $V_{REF}/T$   | $T_A = 0^{\circ}C$ to $70^{\circ}C$                | -    | 0.01 | 0.03     | %/ $^{\circ}C$ |
| Load Regulation                             | $V_{REF}$     | $I_{REF} = 1mA$ to $10mA$                          | -    | 1.0  | 15       | mV             |
| Short-Circuit Output Current                | $I_{SC}$      | $V_{REF} = 0V$                                     | 10   | 35   | 50       | mA             |
| <b>OSCILLATOR SECTION</b>                   |               |  |      |      |          |                |
| Oscillation Frequency                       | $f$           | $C_T = 0.01\mu F$ , $R_T = 12k\Omega$              | -    | 10   | -        | kHz            |
| Frequency Change with Temperature           | $f/T$         | $C_T = 0.01\mu F$ , $R_T = 12k\Omega$              | -    | -    | 2        | %              |
| <b>DEAD TIME CONTROL SECTION</b>            |               |  |      |      |          |                |
| Input Bias Current                          | $I_{BIAS}$    | $V_{CC} = 15V$ , $0V \leq V_4 \leq 5.25V$          | -    | -2.0 | -10      | $\mu A$        |
| Maximum Duty Cycle                          | $D(MAX)$      | $V_{CC} = 15V$ , $V_4 = 0V$<br>$O.C Pin = V_{REF}$ | 45   | -    | -        | %              |
| Input Threshold Voltage                     | $V_{ITH}$     | Zero Duty Cycle                                    | -    | 3.0  | 3.3      | V              |
|   |               | Max. Duty Cycle                                    | 0    | -    | -        |                |
| <b>ERROR AMP SECTION</b>                    |               |  |      |      |          |                |
| Input Offset Voltage                        | $V_{IO}$      | $V_3 = 2.5V$                                       | -    | 2.0  | 10       | mV             |
| Input Offset Current                        | $I_{IO}$      | $V_3 = 2.5V$                                       | -    | 25   | 250      | mA             |
| Input Bias Current                          | $I_{BIAS}$    | $V_3 = 2.5V$                                       | -    | 0.2  | 1.0      | $\mu A$        |
| Common Mode Input Voltage                   | $V_{CM}$      | $7V \leq V_{CC} \leq 40V$                          | -0.3 | -    | $V_{CC}$ | V              |
| Open-Loop Voltage Gain                      | $G_{VO}$      | $0.5V \leq V_3 \leq 3.5V$                          | 70   | 95   | -        | dB             |
| Unit-Gain Bandwidth (Note1)                 | $BW$          | -  | -    | 650  | -        | kHz            |
| <b>PWM COMPARATOR SECTION</b>               |               |  |      |      |          |                |
| Input Threshold Voltage                     | $V_{ITH}$     | Zero Duty Cycle                                    | -    | 4    | 4.5      | V              |
| Input Sink Current                          | $I_{SINK}$    | $V_3 = 0.7V$                                       | -0.3 | -0.7 | -        | mV             |
| <b>OUTPUT SECTION</b>                       |               |  |      |      |          |                |
| Output Saturation Voltage<br>Common Emitter | $V_{CE(SAT)}$ | $V_E = 0$ , $I_C = 200mA$                          | -    | 1.1  | 1.3      | V              |
| Common Collector                            | $V_{CC(SAT)}$ | $V_C = 15V$ , $I_E = -200mA$                       | -    | 1.5  | 2.5      |                |
| Collector Off-State Current                 | $I_C(OFF)$    | $V_{CC} = 40V$ , $V_{CE} = 40V$                    | -    | 2    | 100      | $\mu A$        |
| Emitter Off-State Current                   | $I_E(OFF)$    | $V_{CC} = V_C = 40V$ , $V_E = 0$                   | -    | -    | -100     |                |
| <b>TOTAL DEVICE</b>                         |               |  |      |      |          |                |
| Supply Current                              | $I_{CC}$      | $Pin 6 = V_{REF}$ , $V_{CC} = 15V$                 | -    | 6    | 10       | mA             |
| <b>OUTPUT SWITCHING CHARACTERISTICS</b>     |               |  |      |      |          |                |
| Rise Time                                   | $t_R$         | -  | -    | -    | -        | -              |
| Common Emitter                              | -             | -  | -    | 100  | 200      | ns             |
| Common Collector                            | -             | -  | -    | 100  | 200      |                |
| Fall Time                                   | $t_F$         | -  | -    | -    | -        | -              |
| Common Emitter                              | -             | -  | -    | 25   | 100      | ns             |
| Common Collector                            | -             | -  | -    | 40   | 100      |                |

### Note:

1. This parameter, although guaranteed, is not 100% tested in production.

## Typical Application

### Pulse Width Modulated Step-down Converter

