



igus® Energy Chain
Systems®

Price Index



10 Widths
8 Bending Radii



Product Range

Inner Widths (Bi) in mm:	50, 75, 100, 115, 125, 150, 175, 200, 225, 250
Bending Radii (R) in mm:	100, 125, 150, 175, 200, 225, 250, 300
Pitch:	58,8 mm/link = 17 links/m (999,6 mm)

Unsupported length

- FL_B = unsupported with permitted sag
- FL_G = unsupported with straight upper run

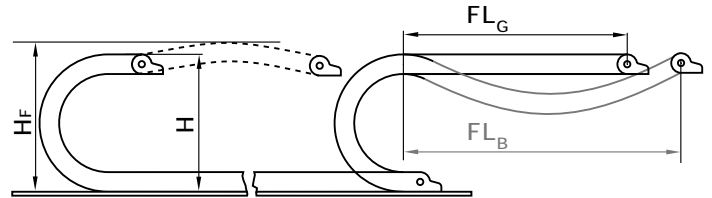

Phone +49- (0) 22 03 96 49-0
Fax +49- (0) 22 03 96 49-222

Interior separation possible

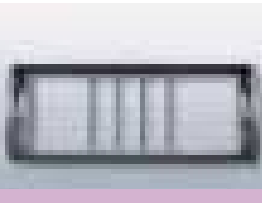

2 options for mounting brackets



igus® GmbH
51127 Cologne

Also available with Quickflange



Hinged, snap-open lids along inner or outer radius

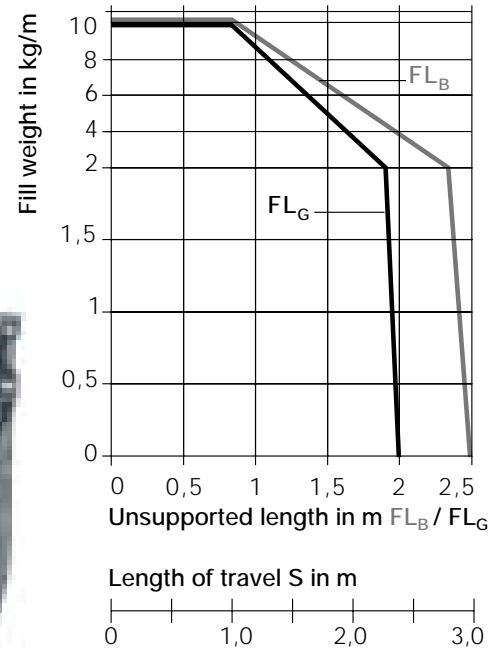
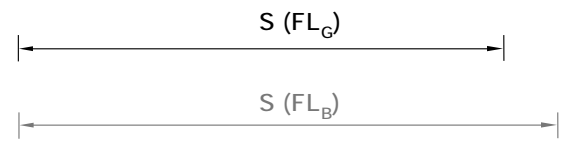
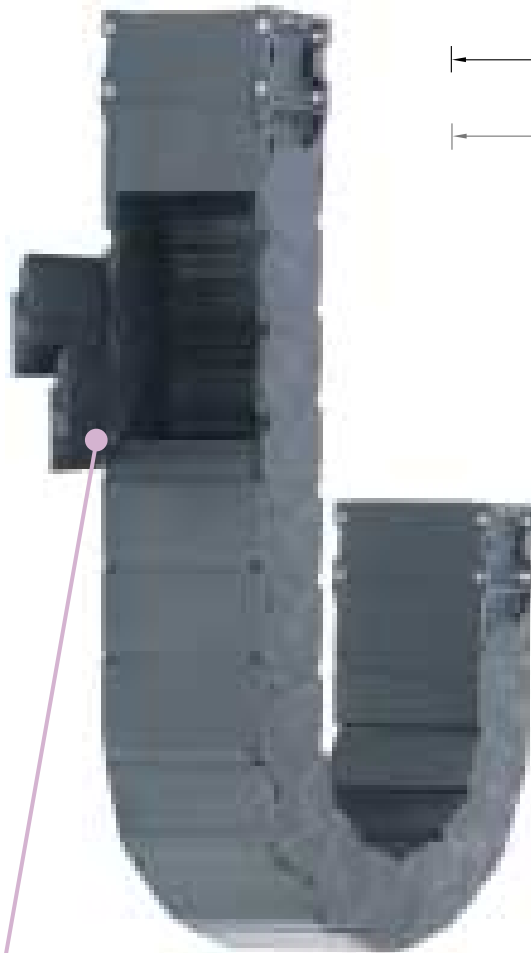

When to use the Series R167/R168:

- If hinged, snap-open accessibility along inner or outer radius is required
- If low-cost, lightweight Energy Tube for many types of applications is required
- If flush mounting option is required
- If chip-repellent features are required



When not to use them:

- If hinged, snap-open accessibility along both radii is required
 - ▶ System E4/100, Series R780, Page 7.66
- If particularly quiet operation is required
 - ▶ Series R, Series R68, Page 6.56

Series R167 - Energy Tube (hinged, snap-open on both sides of the inner radius)

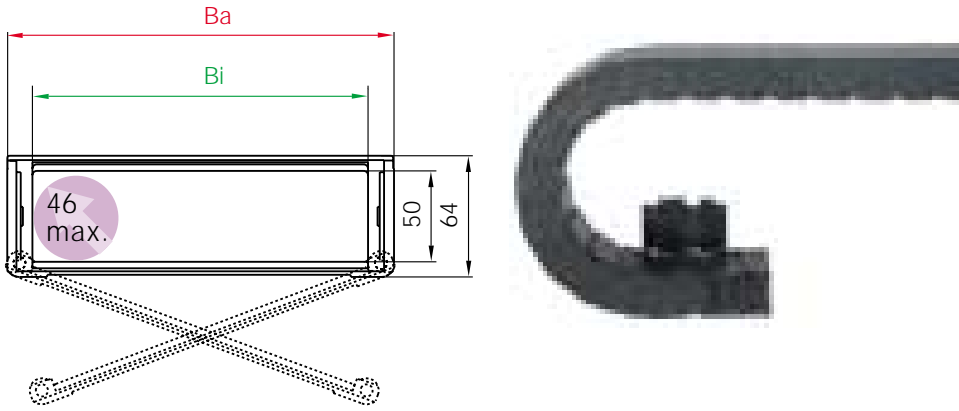

Order Example



167.100.150.0

Standard color
0 = Black

● Other colors
▶ Design,
Page 1.62

Part No.		Bi	Ba	Bending Radii
167.050	Radius	050	068	100 125 150 175 200
167.075	Radius	075	093	225 250 300
167.100	Radius	100	118	
167.115	Radius	115	133	
167.125	Radius	125	143	
167.150	Radius	150	168	
167.175	Radius	175	193	
167.200	Radius	200	218	These bending radii can be combined with every tube width!
167.225	Radius	225	243	
167.250	Radius	250	268	

Supplement part no. with required radius for example 167.100.100.0

Series R168 - Energy Tube (hinged, snap-open on both sides of the outer radius)

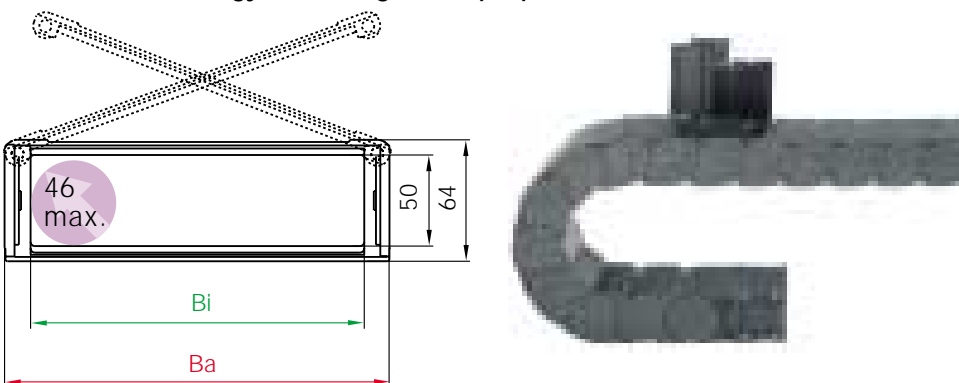

Part No.		Bi	Ba	Bending Radii
168.050*	Radius	050	068	100 125 150 175 200
168.075*	Radius	075	093	225 250 300
168.100	Radius	100	118	
168.115*	Radius	115	133	
168.125*	Radius	125	143	
168.150	Radius	150	168	
168.175*	Radius	175	193	
168.200	Radius	200	218	These bending radii can be combined with every tube width!
168.225*	Radius	225	243	
168.250*	Radius	250	268	

Supplement part no. with required radius for example 168.100.100.0

* Delivery time available upon request

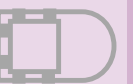

upon request

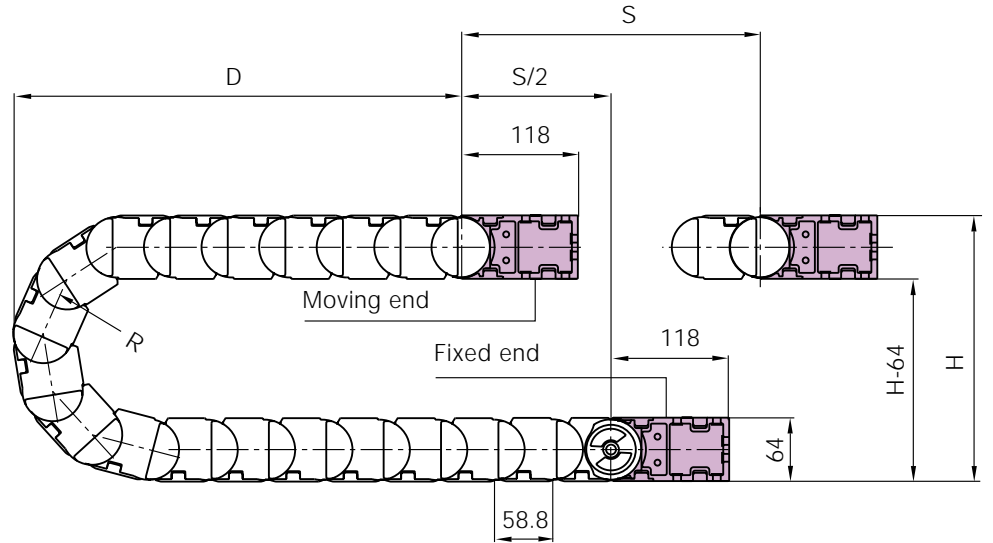

Pitch: = 58,8 mm per link

Links per m: = 17

Tube length: = $\frac{S}{2} + K$

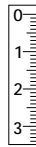

R	100	125	150	175	200	225	250	300
H*	264	314	364	414	464	514	564	664
D	180	205	230	255	280	305	330	380
K	440	510	590	670	750	830	910	1060

*The required clearance height is HF = H + 40 mm (with 2kg/m fill weight)

Please consult igus® if space is particularly restricted.

Vertical Separators

Vertical separators are used to divide the interior of the Energy Tube. They most commonly perform the tasks of distributing the tube's fill weight evenly and keeping dissimilar conduits apart. Separators are removable and adjustable for a variety of chamber widths.

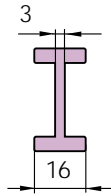
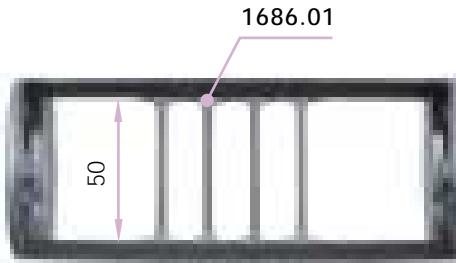

Vertical Separators

Unassembled Part No. 1685.01

Assembled Part No. 1686.01

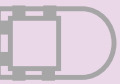
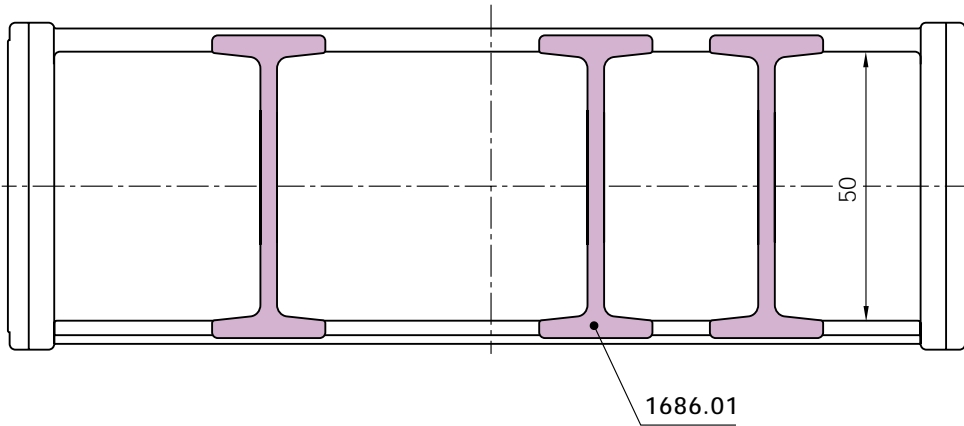

upon request

2 options for all applications

Option 1: Pivoting

1680...1
Moving end

- ⚠ Standard
- ⊕ Pivoting
- ⊕ Universal use
- ⊕ Locked connection to Energy Tube
- ⊕ Long travels with lowered mounting height
- ⊕ Corrosion-resistant
- ⊖ Vertical hanging/standing, unsupported

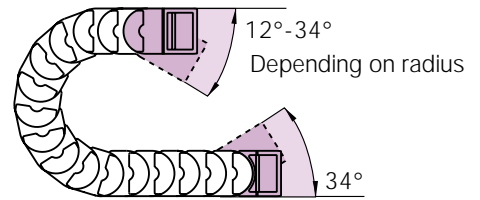

1680...2
Fixed end

Option 1: polymer pivoting

● Standard



Option 2: polymer pivoting

● Quickflange

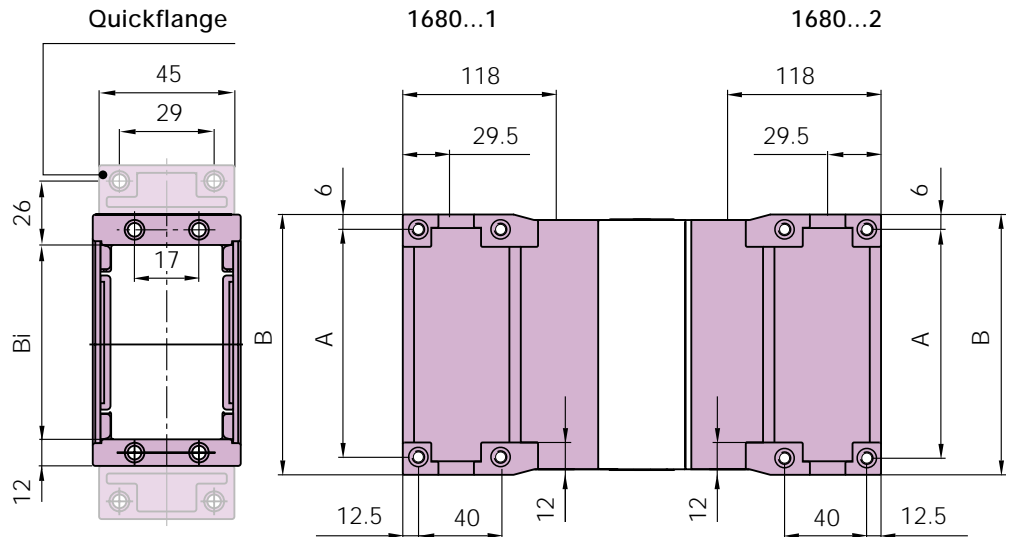

Part No.
Quickflange
● Unassembled
16800.QF

Tube Type	Part No. Full Set	Part No. Quickflange	Dimension A in mm	Dimension B in mm
167/168.050	1680.050.12	1680.050.12QF	62	74
167/168.075	1680.075.12	1680.075.12QF	87	99
167/168.100	1680.100.12	1680.100.12QF	112	124
167/168.115	1680.115.12	1680.115.12QF	127	139
167/168.125	1680.125.12	1680.125.12QF	137	149
167/168.150	1680.150.12	1680.150.12QF	162	174
167/168.175	1680.175.12	1680.175.12QF	187	199
167/168.200	1680.200.12	1680.200.12QF	212	224
167/168.225	1680.225.12	1680.225.12QF	237	249
167/168.250	1680.250.12	1680.250.12QF	262	274

1680...12 = Full set, each part with pin/bore

1680...1 = Mounting bracket with bore

1680...2 = Mounting bracket with pin

The following parts are required for attachment of the mounting brackets:

- Socket head cap bolt M5* DIN 912-8.8 8 pieces/set
- Washer 5,3 DIN 125-ST 8 pieces/set
- Hexagon nut M5 DIN 934-8 8 pieces/set

* The length of the socket head cap bolt is dependent on the thickness of the attachment base.

Option 2: Locking

- Vertical hanging/standing, unsupported
- Universal use
- Extreme accelerations and extreme speeds
- Long travels
- Pivoting at both sides

1680...1
Moving end

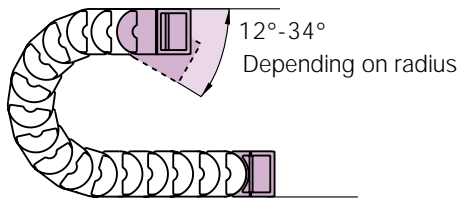

1680...4
Fixed end

Option 2: polymer locking

- Used, for example, with vertically installed tubes

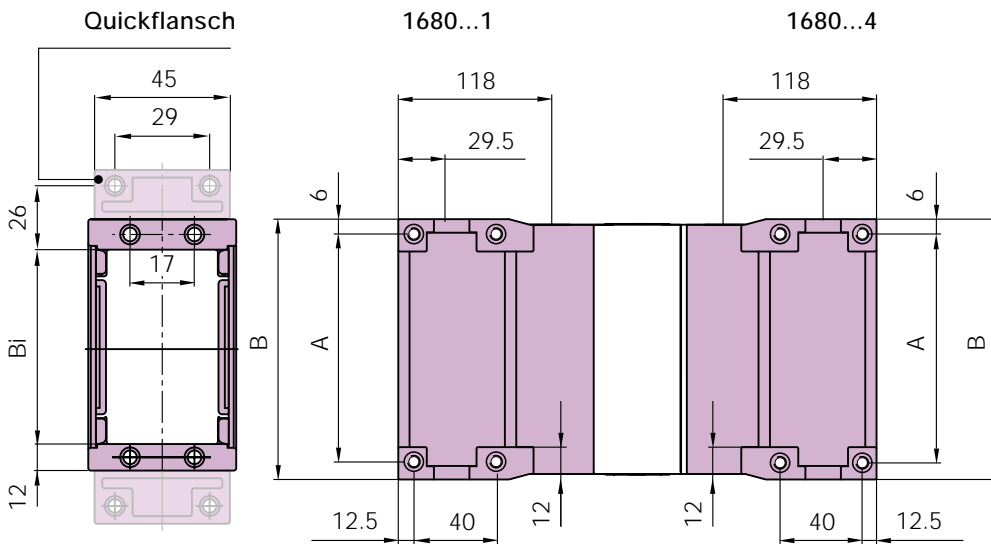

Tube Type	Part No. Full set	Part No. Quickflange	Dimension A in mm	Dimension B in mm
167/168.050	1680.050.14	1680.050.14QF	62	74
167/168.075	1680.075.14	1680.075.14QF	87	99
167/168.100	1680.100.14	1680.100.14QF	112	124
167/168.115	1680.115.14	1680.115.14QF	127	139
167/168.125	1680.125.14	1680.125.14QF	137	149
167/168.150	1680.150.14	1680.150.14QF	162	174
167/168.175	1680.175.14	1680.175.14QF	187	199
167/168.200	1680.200.14	1680.200.14QF	212	224
167/168.225	1680.225.14	1680.225.14QF	237	249
167/168.250	1680.250.14	1680.250.14QF	262	274

Part No. Quickflange
 Unassembled
 16800.QF

1680...14 = Full set, each part with pin/bore
 1680...1 = Mounting bracket with bore
 1680...4 = Mounting bracket with pin

The following parts are required for attachment of the mounting brackets:

- Socket head cap bolt M5* DIN 912-8.8 8 pieces/set
- Washer 5,3 DIN 125-ST 8 pieces/set
- Hexagon nut M5 DIN 934-8 8 pieces/set

* The length of the socket head cap bolt is dependent on the thickness of the attachment base.

Phone +49- (0) 22 03 96 49-0
 Fax +49- (0) 22 03 96 49-222



upon request

Order Example

167.100...

1. Tube selection:

167.100.100.0

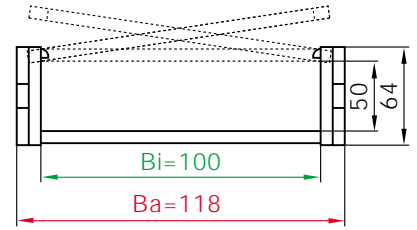
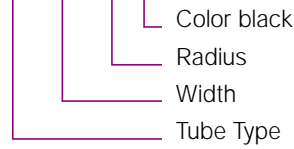

2. Mounting brackets:

1680.100.12

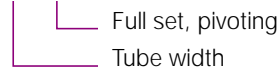

3. Interior separation:

2 vertical separators unassembled, (Part no. 1685.01) or assembled every other tube link, (Part No. 1686.01)

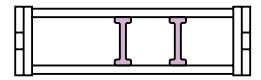

For 5 m tube, color black,

with pivoting mounting brackets:

5 m 167.100.100.0 and 1680.100.12

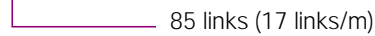

4. Other technical data on guide troughs upon request

Technical Data

Tube Type	Weight Per Link (kg)	Weight Per Meter (kg)
167/168.050	≈ 0,093	≈ 1,580
167/168.075	≈ 0,108	≈ 1,840
167/168.100	≈ 0,123	≈ 2,090
167/168.115	≈ 0,132	≈ 2,240
167/168.125	≈ 0,138	≈ 2,350
167/168.150	≈ 0,153	≈ 2,600
167/168.175	≈ 0,168	≈ 2,860
167/168.200	≈ 0,183	≈ 3,110
167/168.225	≈ 0,198	≈ 3,370
167/168.250	≈ 0,213	≈ 3,620



The following applies to all series listed here:

Material		igumid G
Permitted temperature	°C	-40/+130
Gliding speed (maximum)	m/s	1,5
Unsupported v (maximum)	m/s	10
Flammability class		VDE 0304 IIC UL94 1H

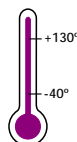

● Details of material properties,

▶ Design, Page 1.61