

3M™ RIBBON CABLE WIREMOUNT SOCKET ASSEMBLY,
1.27mm (0.050") PITCH, 451 SERIES

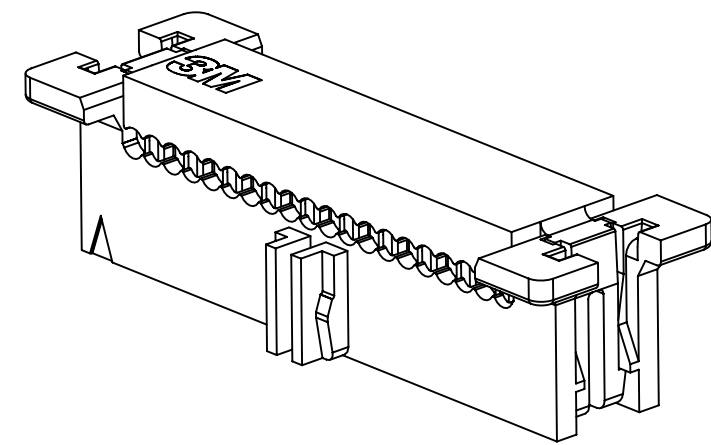

CENTER POLARIZATION
AND FRICTION LATCH

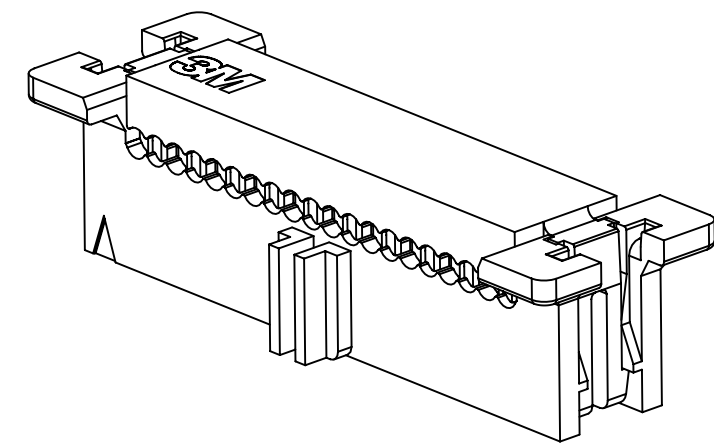

CENTER POLARIZATION
AND NO FRICTION LATCH

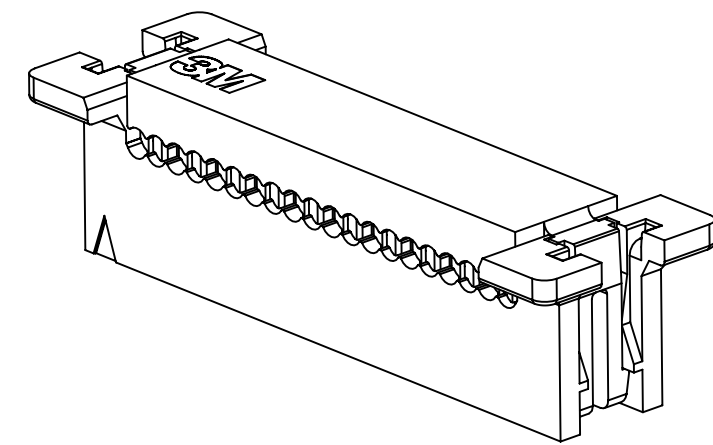

NO CENTER POLARIZATION
AND NO FRICTION LATCH

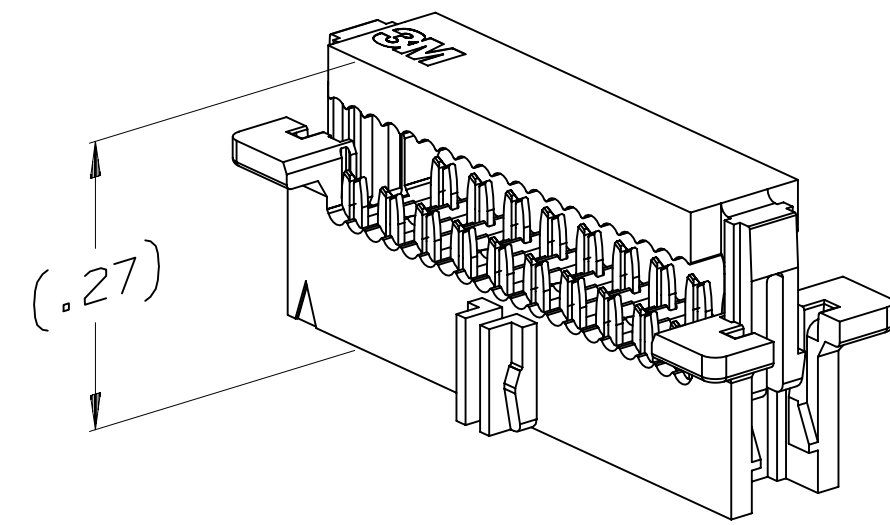
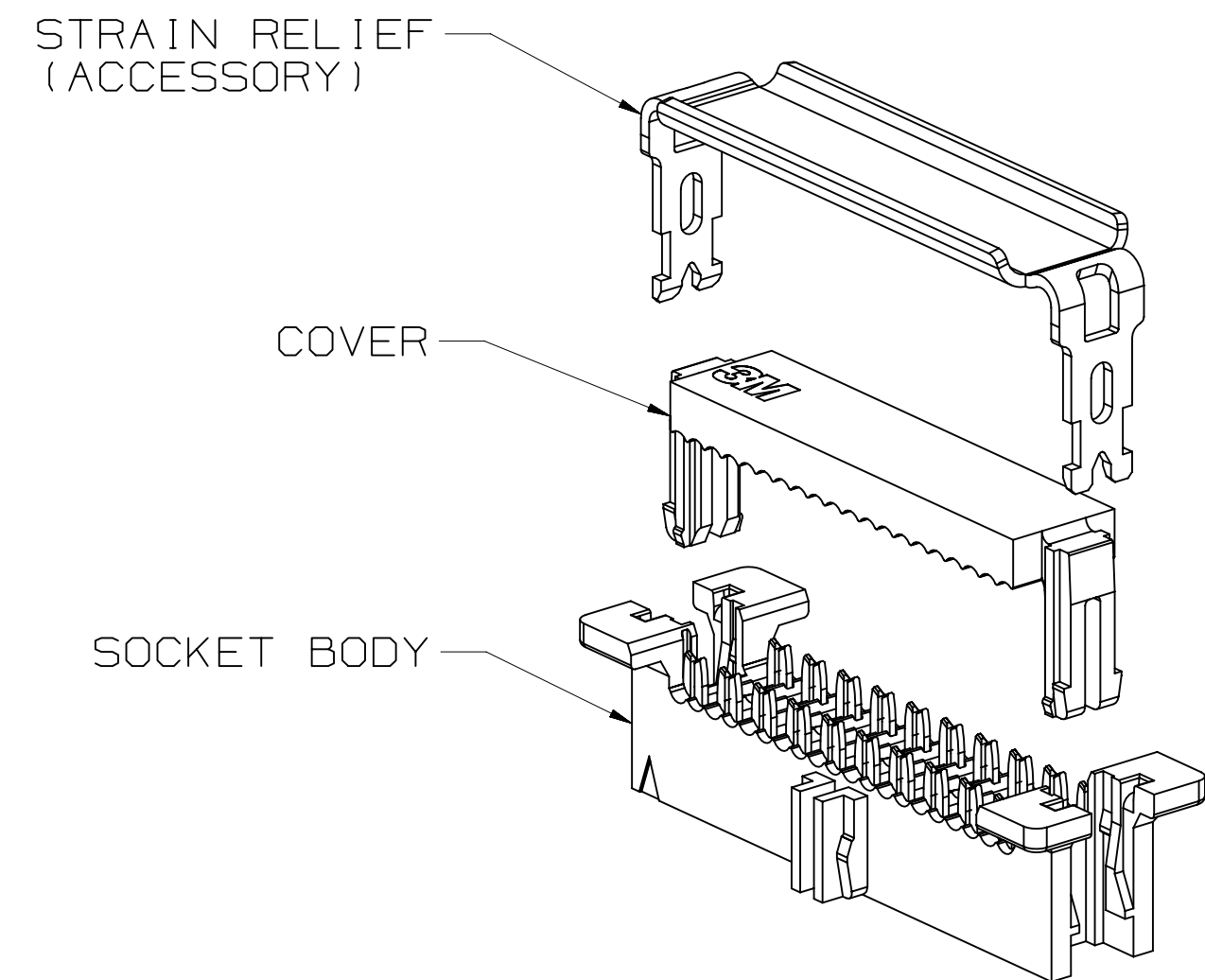

PRE-POSITIONED COVER

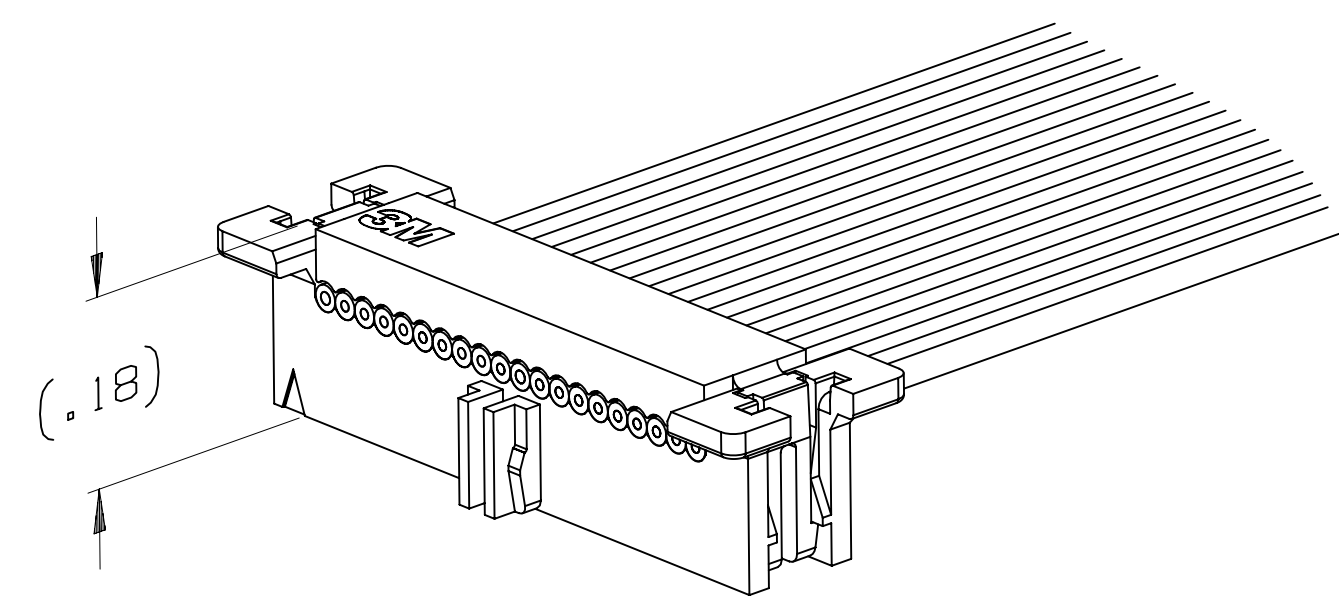

NO STRAIN RELIEF

TERMINATED
CONNECTOR

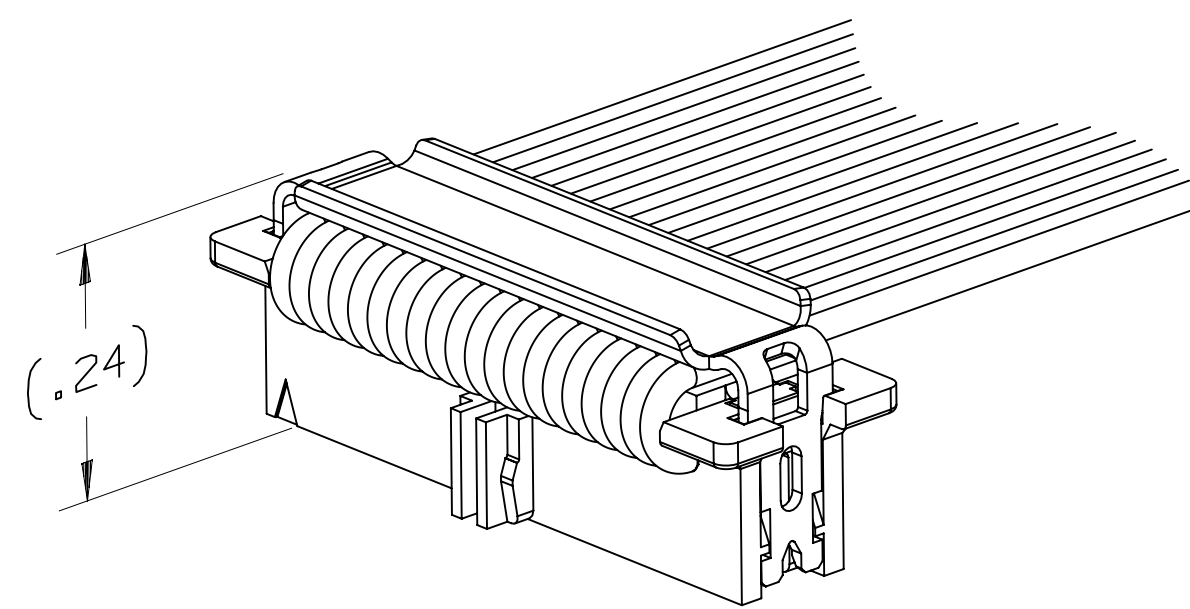

WITH OPTIONAL
STRAIN RELIEF

Performance:	
Current Rating:	1.0 A, all lines energized, 30C temp rise per EIA 364-70
	1.5 A, 6 lines energized, 30C temp rise per EIA 364-70
	2.5 A, 1 line energized, 30C temp rise per EIA 364-70
Voltage Rating:	125V
Insulation Resistance:	> 1 x 10 ⁹ Ohms at 500 VDC
Withstanding Voltage:	1250VACrms at sea level
Operating Temperature:	-65°C to +105°C

- NOTES
- MATERIAL:
BODY: PBT, UL94V-0
COVER: PBT, UL94V-0
STRAIN RELIEF: STAINLESS
STEEL
CONTACTS: BeCu ALLOY.
 - PLATING:
50-150μ" NICKEL UNDERPLATE
30 = 30μ" MIN. GOLD ON WIPING
AREA
00 = FLASH GOLD ON WIPING AREA.
 - RIBBON CABLE COMPATIBILITY:
GENERAL:
0.025" PITCH PVC, 30 AWG,
SOLID OR 7 STRAND.
RECOMMENDED:
3M 3447 AND 3754 SERIES
CABLE.
 - MATING COMPATIBILITY:
3M 1.27mm (0.050"),
SERIES 452 HEADER WITH
LATCH/EJECT OPTION.
TECH SHEET 2437
 - REGULATORY INFORMATION:
ROHS COMPLIANT. SEE THE
REGULATORY INFORMATION
APPENDIX (RIA) IN THE
"ROHS COMPLIANCE" SECTION
OF WWW.3MCONNECTORS.COM
FOR COMPLIANCE INFORMATION
(RIA E1 & C1 APPLY)
 - IN THE EVENT OF CONFLICT
BETWEEN THIS DATA AND THAT
CONTAINED IN THE PRODUCT
SPECIFICATION, THE PRODUCT
SPECIFICATION TAKES PRECEDENT.
 - REFERENCE RELATED DOCUMENTS:
PRODUCT SPECIFICATION:
3M DOC. ID# 78-5102-0091-4.
 - TOOLING AND INSTALLATION
INSTRUCTIONS:
3M DOC. ID# 78-9101-8937-8.
 - OTHER PIN COUNTS AVAILABLE
UPON REQUEST. CONTACT 3M.
 - PACKAGING:
SOCKET: TRAY
COVER: BAG

ORDERING INFORMATION
FOR RAPID INSTALLATION ON
RIBBON CABLE APPLICATIONS

451 XX - 0 X 0 0 XX
 SERIES ——— PLATING
 00 = Au FLASH
 30 = 30μ" GOLD
 POSITION COUNT ———
 04 - 30
 SEE TABLE 1
 CENTER POLARIZATION / FRICTION LATCH
 0 = NO CENTER POLARIZATION (CP) (04-30 POS.)
 1 = CP NO FRICTION LATCH (08 - 30 POS.)
 2 = CP WITH FRICTION LATCH (08 - 30 POS.)
 OPTIONAL FEATURES
 0 = NONE SPECIFIED
 PACKAGING
 0 = STANDARD (TRAYS)

NOTE:
FRICTION LATCH (OPTION 2) IS NOT SUITABLE
FOR HEADER WITH LATCH EJECT OPTION

ACCESSORY: STRAIN RELIEF
3448-451XX

POSITION COUNT
04 - 30

APPLICATION TOOLING:
ALUMINUM: 3443-82-XX

POSITION COUNT
04 - 30

78-5100-2396-9
78-5100-2437-1

REV	ECO	ISSUE DATE AND DESCRIPTION	DRFT	CHKD
D	51884	JAN 08, 2014 ADD DESIGN REF. UPDATE TITLE, ADD TS REF	SJS	SAN
C	50290	OCT 08, 2013 REVISE NOTES 1, 3, 8 & OPERATING TEMP.	JNC	SN
B	48635	JUL 12, 2013 MATCH TEXT FONTS & ADD NOTE 10	JNC	SN
A	46797	MAR 25, 2013 PRODUCTION RELEASE	JNC	SAN

DESIGN REFERENCE	NEXT ASSEMBLY	DATE	DATE
ARM	FEB 11, 2011	MFG	DATE
APPRV	SAN	APPRV	SAN
DATE	FEB 11, 2011	DATE	FEB 11, 2011

DIVISION	3M COMPANY	DIVISION CODE	ISD
Interconnect Solutions			
DO NOT SCALE DRAWING	SCALE 6-1	TOLERANCES EXCEPT AS NOTED	
THIRD ANGLE PROJECTION	INTERPRET PER ASME Y14.5 - 1994	INCHES .00 ± .01 .000 ± .010 .0000 ± .005	MILLIMETERS 0 ± .0 ± .00 ± 0.00 ±
MAX SURFACE ROUGHNESS	1.6 SURFACES	MARKED ONLY	ANGLES

TITLE	RIBBON CABLE SOCKET, .05 X .05 PITCH, 451 SERIES		
CAGE NUMBER	SIZE	DRAWING NO.	REV.
D		78-5100-2436-3	D
MODEL	LISTS	YES	NO
SHT	1	OF	2

3M ELECTRONIC SOLUTIONS DIVISION
INTERCONNECT SOLUTIONS
<http://www.3mconnectors.com>

3M IS A TRADEMARK OF 3M COMPANY.
FOR TECHNICAL, SALES OR ORDERING
INFORMATION CALL 800-225-5373

78-5100-2436-3
DRAWING NUMBER

3M™ RIBBON CABLE WIREMOUNT SOCKET ASSEMBLY,
1.27mm (0.050") PITCH, 451 SERIES

TABLE 1

No. Positions	Dim "A"	Dim "B"	Dim "C"
4	.050	.210	.270
6	.100	.260	.320
8	.150	.310	.370
10	.200	.360	.420
12	.250	.410	.470
14	.300	.460	.520
16	.350	.510	.570
20	.450	.610	.670
30	.700	.860	.920

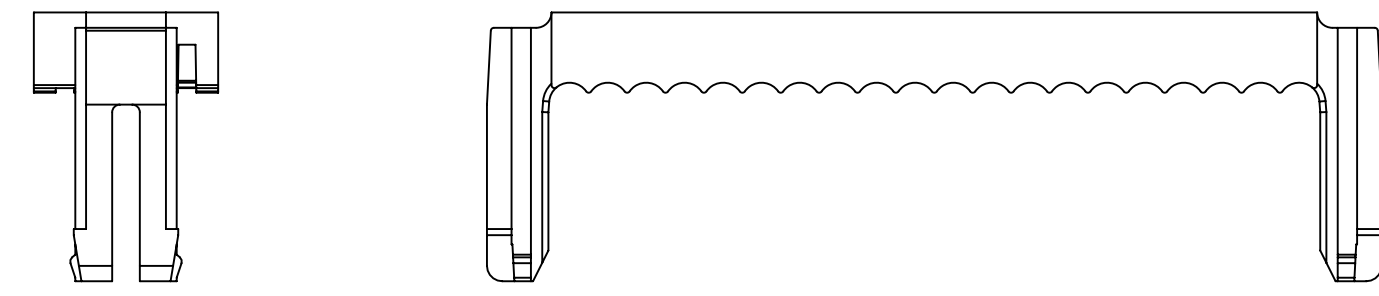

COVER

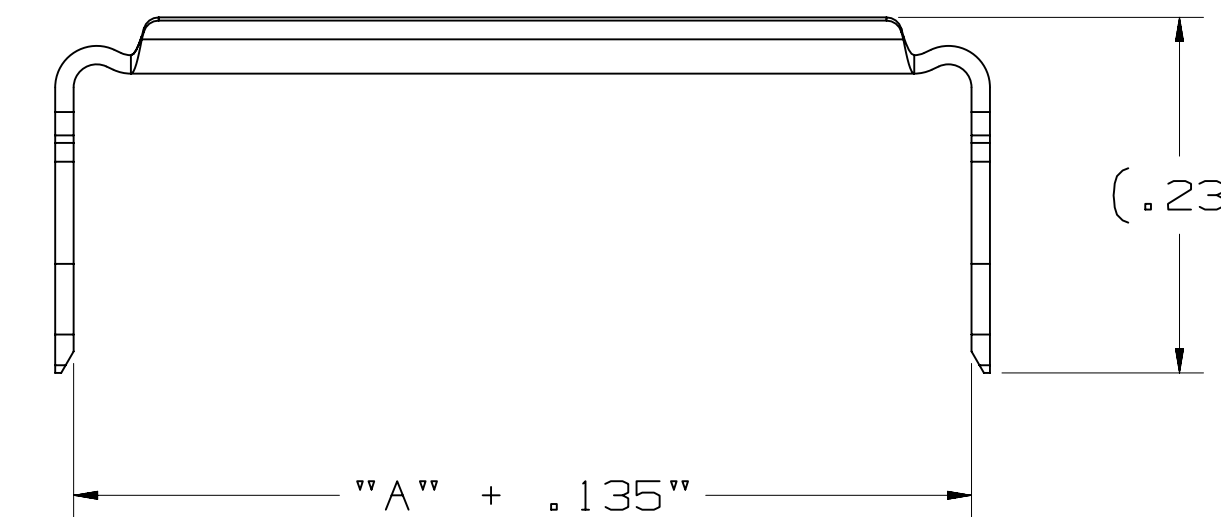
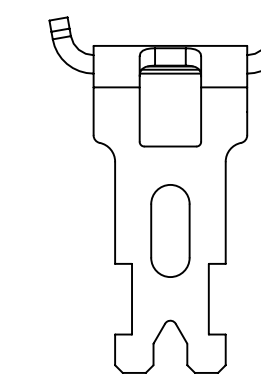
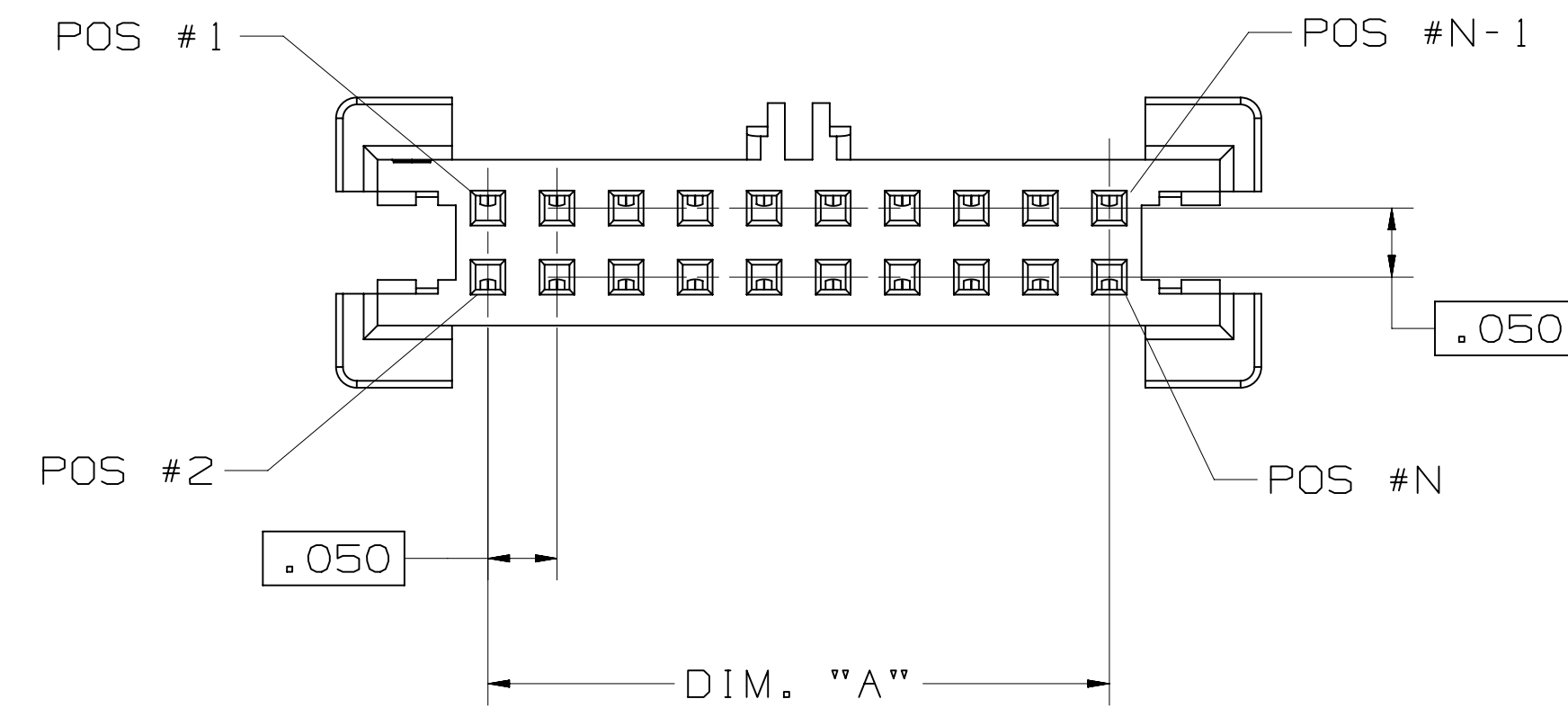
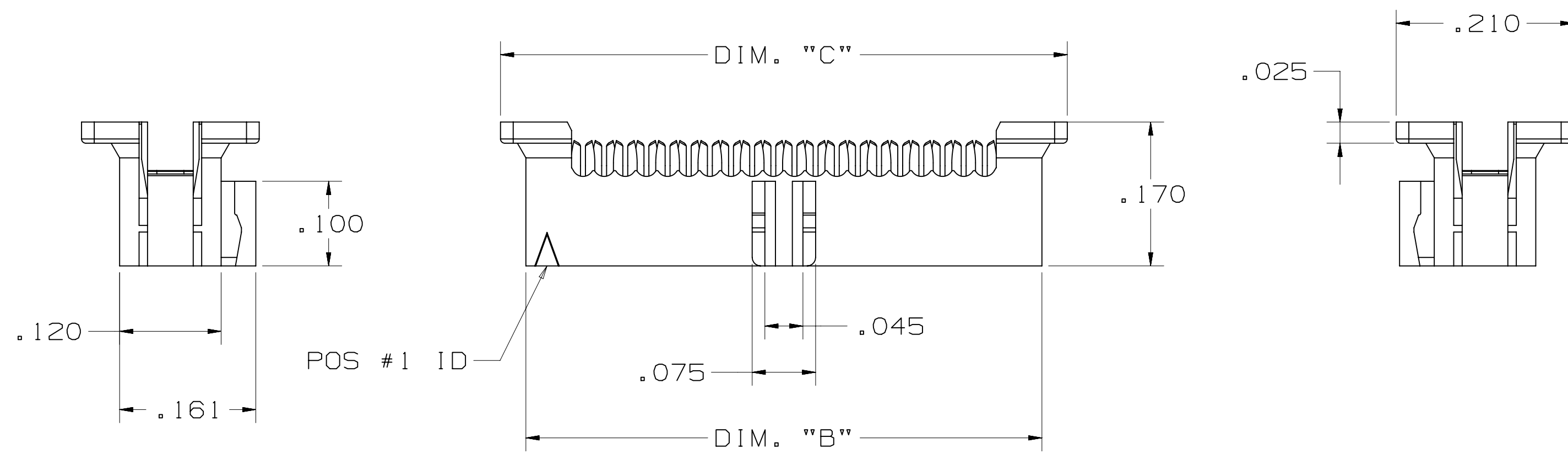

ACCESSORY - STRAIN RELIEF
PART NUMBER 3448-451XX

REV	ECO	DATE	DESCRIPTION	DRFT	CHKD
D	51884	JAN 08, 2014	ADD DESIGN REF, UPDATE TITLE, ADD TS	SJS	SAN
C	50290	OCT 08, 2013	REVISE NOTES 1, 3, 8 & OPERATING TEMP.	JNC	SN
B	48635	JUL 12, 2013	MATCH TEXT FONTS & ADD NOTE 10	JNC	SN
A	46797	MAR 25, 2013	PRODUCTION RELEASE	JNC	SAN

78-5100-2396-9
78-5100-2437-1

DESIGN REFERENCE NEXT ASSEMBLY

DATE FEB 11, 2011

APPROVAL SAN

DO NOT SCALE DRAWING

SCALE 4/1

THIRD ANGLE PROJECTION

INTERPRET PER ASME Y14.5 - 1994

MAX SURFACE ROUGHNESS

MARKED ONLY

3M Center St. Paul, MN 55144

TITLE RIBBON CABLE SOCKET, .05 X .05 PITCH, 451 SERIES

CAGE NUMBER D78-5100-2436-3

REV. D

MODEL SHEET 2 OF 2