

# Pfannenberg Filterfan 4<sup>th</sup> Generation

- Ⓓ **Montage- und Betriebsanleitung**  
Filterlüfter für Schaltschränke und Gehäuse
- ⒼⒷ **Installation- and operating instructions**  
Filter fans for switch cabinets and housings
- Ⓕ **Notice de montage et d'utilisation**  
Ventilateur à filtre pour armoires de distribution et boîtiers
- ⒼⓃ **Montage- en gebruikshandleiding**  
Filterventilator voor schakelkasten en behuizingen
- Ⓕ **Installations och bruksanvisning**  
Filterfläkt för elskåp och kapslingar
- Ⓘ **Istruzioni di montaggio e per l'uso**  
Ventilatore con filtro per quadri elettrici e alloggiamenti
- Ⓔ **Instrucciones de montaje y para uso**  
Ventilador con filtro para armarios eléctricos y carcasas
- ⒼⓈ **Инструкция по установке и эксплуатации**  
Вентилятор с фильтром для распределительных шкафов и корпусов приборов

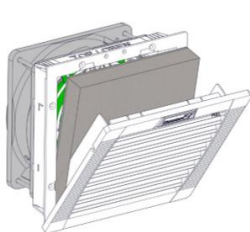

IP54 / TYPE PF / PF EMC

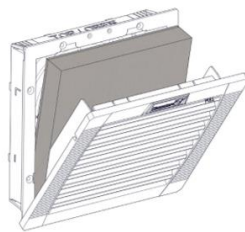

IP54 / TYPE PFA / PFA EMC

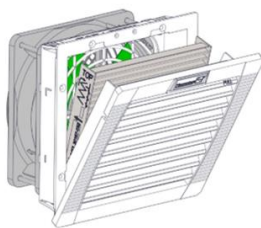

IP55 / TYPE PF / PF EMC



IP55 / TYPE PFA / PFA EMC

- Ⓓ Lesen Sie diese Anweisung und bewahren Sie diese auf.
- ⒼⒷ Read and save these instruction.
- Ⓕ Lisez et sauvegardez ces instructions.
- ⒼⓃ Deze instructies lezen en bewaren.
- Ⓕ Läs och spara dessa anvisningar.
- Ⓘ Legga e salvi queste istruzioni.
- Ⓔ Lea y salve estas instrucciones.
- ⒼⓈ Прочитайте, пожалуйста, данную инструкцию и сохраните ее

Stand 02.2022



085408082ak

**Pfannenberg**  
ELECTRO-TECHNOLOGY FOR INDUSTRY



[www.pfannenberg.com](http://www.pfannenberg.com)

- (D) Ausschnitte und Abmessungen  
 (GB) Cut outs and dimensions  
 (F) Découpes de montage et dimensions  
 (NL) Uitsparingen en afmetingen

- (S) Urklipp och dimensioner  
 (I) Dima di foratura e dimensioni  
 (E) Plantillas y dimensiones  
 (RUS) Монтажные вырезы и габаритные размеры

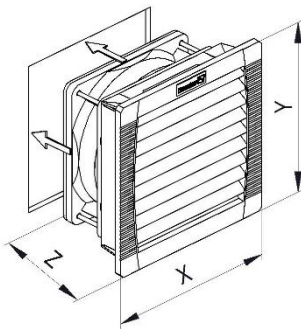
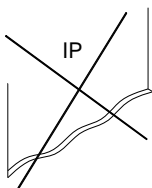
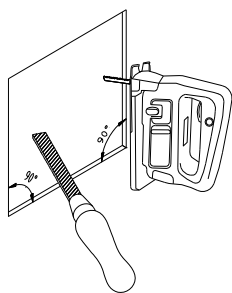
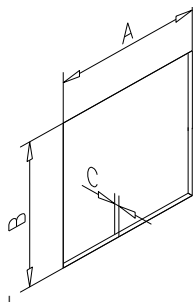

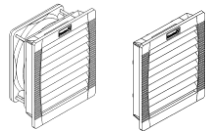
		A = B mm(inch)		X = Y mm(inch)	Z mm(inch)		
		Standard	EMC		PF		PFA
		$C \leq 2(0,08) = A \begin{matrix} +1(0,04) \\ 0 \end{matrix}$ $C > 2(0,08) \leq 3(0,12) = A \begin{matrix} +2(0,08) \\ +1(0,04) \end{matrix}$			±0,5 (0,02)	DC	AC
PF 11000	PFA 10000	92(3,62)	93(3,66)	109(4,29)		53(2,09)	66(2,6)
PF 22000	PFA 20000	125(4,92)	126,5(4,98)	145(5,71)	69(2,72)	75(2,95)	31(1,22)
PF 32000	PFA 30000	177(6,97)	178(7,01)	202(7,95)	87(3,42)	93(3,66)	40(1,57)
PF 42500	PFA 40000	223(8,78)	224(8,82)	252(9,92)	103(4,06)		44(1,73)
PF 43000					103(4,06)	119(4,68)	
PF 65000	PFA 60000	292(11,5)	292(11,5)	320(12,6)	157(6,18)		46(1,81)
PF 65000 SL					131(5,16)		
PF 66000					157(6,18)		
PF 67000					157(6,18)		
PF 67000 SL					134(5,28)		

- (D) ACHTUNG: Nur in vertikaler Einbaulage und bei Nicht-Zerstören der Dichtung ist die Schutzart IP54/ IP55/ Type 12 gewährleistet. Funktionsgewährleistung nur bei elektrisch leitfähiger Verbindung zwischen EMV- Schirmblech und Montageausschnitt.  
 (GB) CAUTION: The degree of protection IP54/ IP55/ Type 12 cannot be guaranteed unless the vertical installation position and a non-destructed foam gasket are ensured. Function cannot be guaranteed unless there is a conductive connection between the EMC-shield and the mounting cut out.  
 (F) ATTENTION: Le degré de protection IP54 / IP55 / Type 12 n'est garanti qu'en position de montage verticale et si le joint n'est pas détruit. La fonction n'est garantie que dans le cas d'un contact électro conducteur entre la tôle de protection CEM et la découpe pour le montage.  
 (NL) OPPASSEN: Beschermingsgraad IP54 / IP55 / Type 12 is alleen gegarandeerd in een verticale inbouwpositie en als de afdichting niet wordt vernietigd. De functiegarantie geldt uitsluitend als er tussen de EMC-afscherming en de montage-uitsnijding een elektrisch geleidende verbinding bestaat.  
 (S) VARNING: Skyddsklass IP54/ IP55/ Type 12 gäller endast vid vertikal monteringsläge och om tätningen inte förstörs. Funktionsgarantin gäller endast under förutsättning att det finns en elektrisk ledande förbindelse mellan EMC-skärmsplåten och monteringsutskarningen.  
 (I) ATTENZIONE: Il grado di protezione IP54/ IP55/ Type 12 può essere garantito esclusivamente tramite una posizione di montaggio verticale e non interferendo con la guarnizione di tenuta. Il funzionamento è garantito solo in caso di possibilità di collegamento elettricamente conduttibile fra lo schermo in lamiera EMC e l'apertura di montaggio.  
 (E) PRECAUCION: El grado de protección IP54 / IP55 / Tipo 12 solo se garantiza en una posición de instalación vertical y si la junta no está destruida. Sólo se garantiza el funcionamiento con una conexión eléctrica conductiva entre la chapa de protección EMC y el recorte de montaje.  
 (RUS) Внимание: Степень защиты IP54/ IP55/ Тип 12 гарантируется только в вертикальном монтажном положении и в том случае, если уплотнение не нарушено. Функционирование возможно при наличии токопроводящего соединения между уплотнительной лентой EMC и монтажной стеной.

- (D)** Elektrischer Anschluss
- (GB)** Power connection
- (F)** Branchement électrique
- (NL)** Elektrische aansluiting

- (S)** Elanslutning
- (I)** Allacciamento elettrico
- (E)** Conexión de energía
- (RU)** Электрическое подключение

DC- 12/24/48V

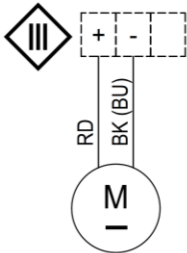

AC- 24V

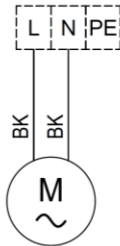

AC- 230/115V

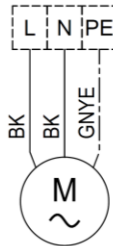

AC- 230/115V

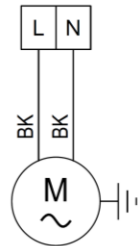

AC- 230/115V

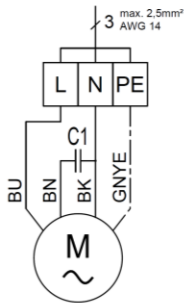

AC- 400V

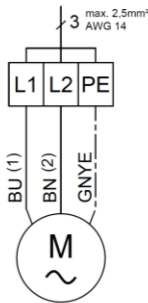

AC- 400/460V \*

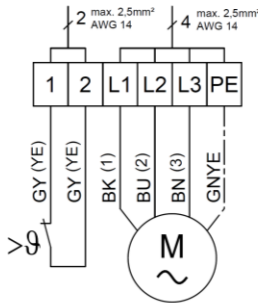

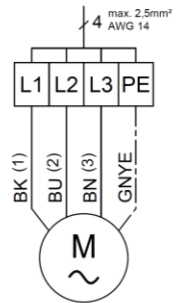

PF 67000 SL  
AC- 400/460V



- (D)** Mindestabstand zwischen Lichtbogen bildenden Bauteilen und Filter: 30,5cm (12") (UL508A sec. 22)  
Der Anschluss darf nur durch eine Elektrofachkraft erfolgen!  
\* HINWEIS: Schließen Sie den in die Wicklung eingebauten Temperaturwächter an einem Motorschutzschalter an.
- (GB)** Minimum distance of 30,5cm (12") between arcing parts and filters (acc. UL508A sec. 22)  
The connection may only be carried out by a qualified electrician!  
\* NOTE: Connect the built-in temperature monitor in the winding to a motor circuit breaker.
- (F)** Distance minimale entre les pièces formant un arc et les filtres: 30,5 cm (12") (UL508A sec. 22)  
Le raccordement ne doit être effectué que par un électricien qualifié!  
\* REMARQUE: raccordez le contrôleur de température intégré à la bobine à un disjoncteur-protecteur.
- (NL)** Minimum afstand tussen lichtbogen vormende componenten en filters: 30,5cm (12") (UL508A sec. 22)  
De aansluiting mag alleen worden uitgevoerd door een gekwalificeerde elektricien!  
\* AANWIJZING: Sluit de in de wikkeling ingebouwde temperatuurbewaking op een motorbeveiligingsschakelaar aan.
- (S)** Minsta avstånd mellan de ljusbågsbildande delar och filtret: 30,5 cm (12") (UL508A sec. 22)  
Anslutningarna får endast utföras av behörige elektriker!  
\* ANVISNING: Anslut temperaturvakten som är monterad i lindningen till ett motorskydd.
- (I)** Distanza minima fra gli elementi che formano l'arco e il filtro: 30,5 cm (12") (UL508A sec. 22)  
Il collegamento può essere effettuato solo da un elettricista qualificato!  
\* NOTA: Collegare il termostato integrato nell'avvolgimento a un salvamotore.
- (E)** Distancia mínima entre los componentes del arco eléctrico y los filtros: 30,5 cm (12") (UL508A sec. 22)  
¡La conexión solo puede ser realizada por un electricista calificado!  
\* NOTA: Conecte el controlador de temperatura montado en el devanado en un interruptor protector de motor.
- (RU)** Минимальное расстояние между деталями, образующими электродугу, и фильтром: 30,5 cm (12") (UL508A sec. 22)  
Подключение может выполняться только квалифицированным электриком!  
\* УКАЗАНИЕ: Подсоедините встроенное в обмотку реле температуры к защитному выключателю двигателя.

- (D) Technische Daten  
 (GB) Technical data  
 (F) Caractéristiques Techniques  
 (NL) Technische gegevens

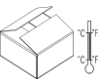
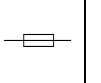

- (S) Tehniska data  
 (I) Dati tecnici  
 (E) Datos técnicos  
 (RU) Технические данные

	U +/- DC	U ~ 50/60 Hz * 60Hz	P	I				
	V	V	W	A				standard (EMC)
PF 11.000	12	--	2,4	0,2	-40.. + 55°C -40.. +131°F	-40.. + 70°C -40.. +158°F	6A	0,16 (0,19)
PF 11.000	24	--	2,4	0,1				
PF 11.000	48	--	2,6	0,05				
PF 11.000	--	24	12/11	0,5/0,5				
PF 11.000	--	115	12/11	0,15/0,15				
PF 11.000	--	230	12/11	0,07/0,06				
PF22.000	12	--	5	0,42	-40.. + 55°C -40.. +131°F	-40.. + 70°C -40.. +158°F	6A	0,44 (0,49)
PF22.000	24	--	5	0,21				
PF22.000	48	--	5	0,1				
PF22.000	--	24	20/20	1,05/1,02				
PF22.000	--	115	20/20	0,235/0,23				
PF22.000	--	230	19/18	0,12/0,18				
PF 32.000	12	--	5	0,42	-40.. + 55°C -40.. +131°F	-40.. + 70°C -40.. +158°F	6A	0,61 (0,7)
PF 32.000	24	--	5	0,21				
PF 32.000	48	--	5	0,1				
PF 32.000	--	115	20/20	0,235/0,23				
PF 32.000	--	230	19/18	0,12/0,18				
PF 42.500	12	--	6	0,5				-40.. + 55°C -40.. +131°F
PF 42.500	24	--	4,7	0,2				
PF 42.500	48	--	4,6	0,1				
PF 42.500	--	115	18/17	0,25/0,25				
PF 42.500	--	230	18/17	0,12/0,1				
PF 43.000	12	--	12	1	-40.. + 55°C -40.. +131°F	-40.. + 70°C -40.. +158°F	6A	
PF 43.000	24	--	12	0,5				
PF 43.000	48	--	11	0,23				
PF 43.000	--	115	40/40	0,5/0,5				
PF 43.000	--	230	45/39	0,32/0,26				
PF 43.000	--	400	41/38	0,13/0,13				
PF 65.000	--	115	79/95	0,69/0,84	-40.. + 55°C -40.. +131°F	-40.. + 70°C -40.. +158°F	6A	3,2 (3,43)
PF 65.000	--	230	80/100	0,35/0,45				
PF 65.000 SL	--	115	64/80	0,58/0,7	-40.. + 55°C -40.. +131°F	-40.. + 70°C -40.. +158°F	6A	3,3 (3,53)
PF 65.000 SL	--	230	64/80	0,29/0,35				
PF 66.000	--	115	125/172	1,1/1,5	-40.. + 55°C -40.. +131°F	-40.. + 70°C -40.. +158°F	6A	3,2 (3,43)
PF 66.000	--	230	120/160	0,53/0,72				
PF 66.000	--	400/460	110/160	0,19/0,23				
PF 67.000	--	115	135/196	1,18/1,71	-40.. + 55°C -40.. +131°F	-40.. + 70°C -40.. +158°F	6A	3,7 (3,93)
PF 67.000	--	230	140/197	0,62/0,86				
PF 67.000	--	400/460	113/160	0,25/0,27				
PF 67.000 SL	24	--	128	7	-40.. + 55°C -40.. +131°F	-40.. + 60°C -40.. +140°F	10A	3,45 (3,68)
PF 67.000 SL	--	115	124/166	1,1/1,45				
PF 67.000 SL	--	230	115/165	0,51/0,70	-40.. + 55°C -40.. +131°F	-40.. + 70°C -40.. +158°F	6A	3,9 (4,13)
PF 67.000 SL	--	400/460	110/165	0,2/0,23				
PFA 10.000					-40.. + 55°C -40.. +131°F	-40.. + 70°C -40.. +158°F	--	0,06 (0,09)
PFA 20.000								0,12 (0,18)
PFA 30.000	--	--	--	--				0,26 (0,35)
PFA 40.000								0,46 (0,62)
PFA 60.000								0,7 (0,93)

- (D) Ersatzteilbeschaffung  
 (GB) Ordering spare parts  
 (F) Approvisionnement en pièces détachées  
 (NL) Bestelling van onderdelen

- (S) Beställning av reservdelar  
 (I) Fornitura delle parti di ricambio  
 (E) Adquisición de repuestos  
 (RU) Приобретение запасных деталей

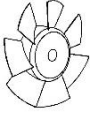
**www.pfannenber.com · spareparts@pfannenber.com**

	U +/- DC	U ~ 50/60 Hz		IP54/ TYPE 12  5x	IP 55/ TYPE 12  5x
PF 11.000	12V	-	18611000036	18611600029	--
	24V	-	18611000039		
	48V	-	18611000042		
	-	24V	18611000005		
	-	115V	18611000028		
	-	230V	18611000032		
PFA 10.000	--	--	--		
PF 22.000	12V	-	18611000025	18611600030	18611600034
	24V	-	18611000026		
	48V	-	18611000027		
	-	24V	18611000006		
	-	115V	18611000009		
	-	230V	18611000016		
PFA 20.000	--	--	--		
PF 32.000	12V	-	18611000025	18611600031	18611600035
	24V	-	18611000026		
	48V	-	18611000027		
	-	24V	18611000006		
	-	115V	18611000009		
	-	230V	18611000016		
PFA 30.000	--	--	--		
PF 42.500	12V	-	18611000037	18611600032	18611600036
	24V	-	18611000040		
	48V	-	18611000054		
	-	115V	18611000029		
	-	230V	18611000033		
PF 43.000	12V	-	18611000055	18611600032	18611600036
	24V	-	18611000056		
	48V	-	18611000057		
	-	115V	18611000012		
	-	230V	18611000019		
	-	400V	18611000022		
PFA 40.000	--	--	--		
PF 65.000	-	115V	18611000047	18611600033	18611600037
	-	230V	18611000044		
PF 66.000	-	115V	18611000048		
	-	230V	18611000045		
PF 67.000	-	400/460V	18611000050		
	-	115V	18611000049		
PF 67.000	-	230V	18611000046		
	-	400/460V	18611000051		
PFA 60.000	--	--	--		
PF 65.000 SL	-	115V	18611000004	18611600033	18611600037
	-	230V	18611000001		
PF 67.000 SL	24V	-	18611000076		
	-	115V	18611000003		
	-	230V	18611000000		
	-	400/460V	18611000065		

- Ⓓ Filterwechsel /Wartung
- ⒼⒸ Filter change /Maintenance
- Ⓕ Remplacement de la cartouche Filtrante / Entretien
- ⒸⒶ Filter vervanging /Onderhoud

- Ⓗ Filterbyte / Underhåll
- Ⓘ Filtri di ricambio / Manutenzione
- Ⓔ Cambio de filtro / Mantenimiento
- ⓂⓈ Замена фильтра/ Техническое обслуживание

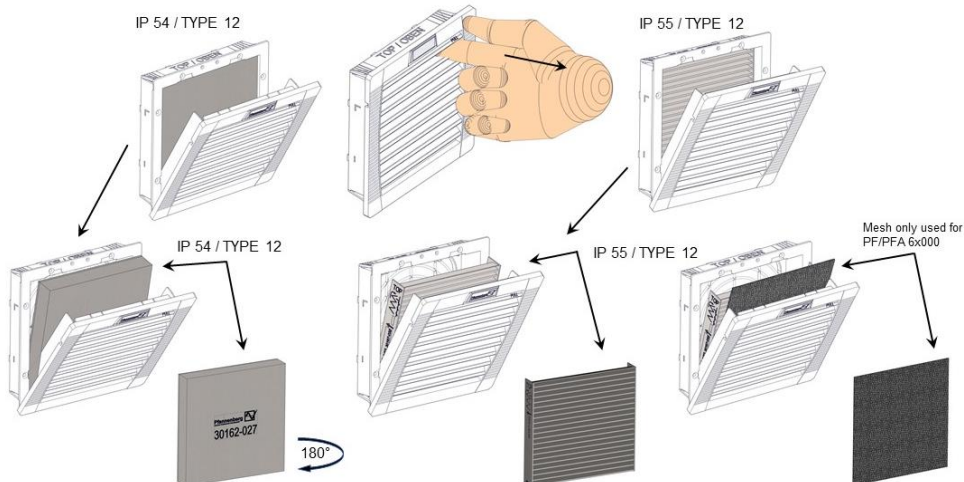

- Ⓓ IP 54/ 55/ TYPE 12: Auf korrekte Einbaulage des Filters achten  
Empfohlene Austauschintervalle unter [www.pfannenberg.com/manuals](http://www.pfannenberg.com/manuals).
- ⒼⒸ IP 54/ 55/ TYPE 12: Make sure that the filter is installed in the proper position.  
Recommended replacement intervals can be found at [www.pfannenberg.com/manuals](http://www.pfannenberg.com/manuals).
- Ⓕ IP 54/ 55/ TYPE 12: Veillez à insérer correctement le filtre  
Les intervalles de remplacement recommandés se trouvent sur [www.pfannenberg.com/manuals](http://www.pfannenberg.com/manuals).
- ⒸⒶ IP 54/ 55/ TYPE 12: Op correcte inbouwpositie van het filter letten  
Aanbevolen vervangintervallen op [www.pfannenberg.com/manuals](http://www.pfannenberg.com/manuals).
- ⓂⓈ IP 54/ 55/ ZYPE 12: Beakta korrekt monteringsläge för filtret  
För rekommenderade bytesintervall se [www.pfannenberg.com/manuals](http://www.pfannenberg.com/manuals).
- Ⓘ IP 54/ 55/TYPE 12: Rispettare la corretta posizione di montaggio del filtro.  
Gli intervalli di sostituzione consigliati sono indicati su [www.pfannenberg.com/manuals](http://www.pfannenberg.com/manuals).
- Ⓔ IP 54/ 55/TYPE 12: Procure que la posición de montaje del filtro sea la correcta  
Intervalos de cambio recomendados en [www.pfannenberg.com/manuals](http://www.pfannenberg.com/manuals).
- ⓂⓈ IP 54/ 55/ TYPE 12: Следите за правильным положением фильтра  
Рекомендуемые интервалы замены можно найти на сайте [www.pfannenberg.com/manuals](http://www.pfannenberg.com/manuals).

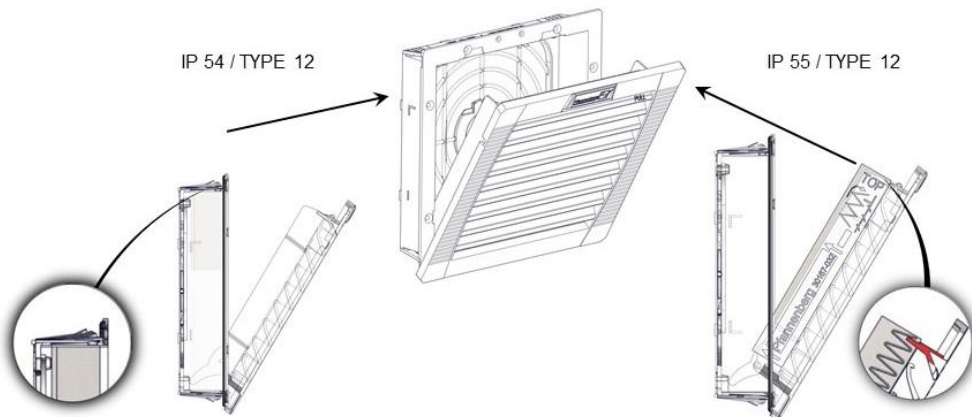

(D) Wechsel der Luftförderrichtung

(GB) Changing the air flow direction

(F) Changement de la direction de l'air

(NL) Omwisselen van de luchttransportrichting

(S) Ändring av riktning för luftmatning

(I) Cambio di direzione del flusso d'aria

(E) Cambio de dirección del flujo de aire

(RU) Изменение направления движения воздуха

### PF 1x.000 – PF 4x.000

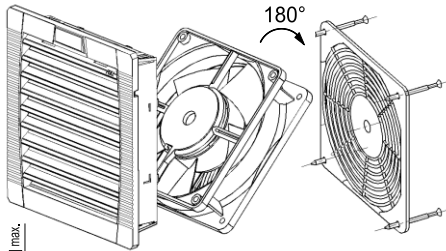

### PF 6x.000 SL

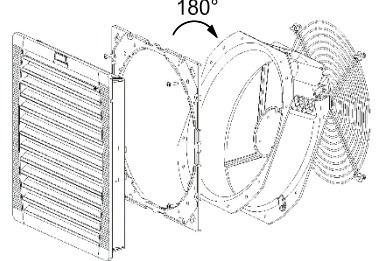

### PF 6x.000

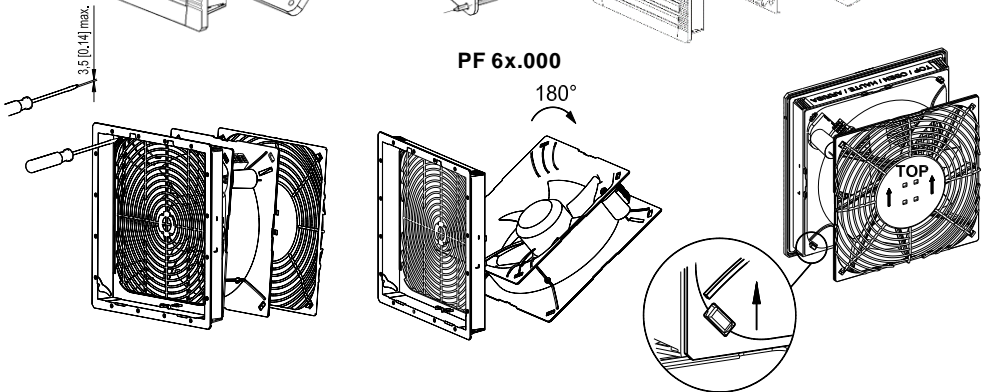

(D) Verwenden Sie **ausschließlich Original Pfannenberg Ersatzteile**, anderenfalls erlöschen Gewährleistung und Zulassungen. Weiterhin sind bei Nichtverwendung der Original Ersatzteile Schutzarten und Leistungsdaten nicht mehr sichergestellt, die Schutzart reduziert sich dann auf Type 1.

(GB) Warranty and licenses **are limited to original Pfannenberg spare parts** and become void if other spare parts are used. Furthermore, ingress protection and capacity levels are no longer ensured if original Pfannenberg spare parts are not used. As a result the ingress protection will be reduced to Type 1.

(F) Veuillez utiliser **exclusivement les pièces détachées d'origine de Pfannenberg**, sinon la garantie et les homologations ne sont plus applicables. Il en va de même pour les types de protection et les caractéristiques de performance, la protection se réduit alors à type 1.

(NL) Gebruik **uitsluitend originele onderdelen van Pfannenberg**, omdat anders garantiwaarborgen en certificeringen vervallen. Tevens zijn bij het niet gebruiken van originele onderdelen beveiligingsgraden en prestatiespecificaties niet langer gewaarborgd. In dit geval vermindert de beveiligingsgraden tot type 1.

(S) Använd **uteslutande Pfannenbergs original reservdelar**, annars upphör garantin att gälla. Vidare kan eventuella fel eller reparationer som beror på att inte original Pfannenberg reservdelar används leda till att skyddsklass och effektdata inte längre säkerställas. I det tillfället skyddsklassen vilja reduceras till på maskin 1.

(I) Utilizzare **esclusivamente parti di ricambio originali Pfannenberg**, pena l'estinzione della garanzia e delle autorizzazioni. Inoltre, in caso di mancato utilizzo delle parti di ricambio originali, non sono più garantiti i tipi di protezione e le caratteristiche di funzionamento. Di conseguenza il grado di protezione sarà ridotto a tipo 1.

(E) Utilice **únicamente repuestos originales de Pfannenberg**; de lo contrario, quedarán sin validez la garantía y las licencias. Además, en caso de no usar dichos repuestos originales, no se podrán garantizar la seguridad ni los datos de rendimiento. En este caso el tipo de protección se reduce al tipo 1.

(RU) Используйте **только оригинальные запасные части от фирмы Pfannenberg**, в противном случае прекращается действие гарантии и допуска к эксплуатации. Кроме того, мы не гарантируем при использовании неоригинальных деталей соблюдение требований по категории защиты и рабочих характеристик. Вид защиты в этом случае снижается до категории 1.

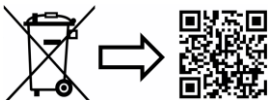

[www.pfannenberg.com/disposal](http://www.pfannenberg.com/disposal)



## Konformitätserklärung / Declaration of Conformity

gemäß den EG-Richtlinien / according to EC directives

- **Elektromagnetische Verträglichkeit / Electromagnetic compatibility 2014/30/EC (L96, 29.03.14, S. 79-106)**
- **Maschinenrichtlinie / Machinery directive 2006/42/EC (L157, 09.06.06, S. 24-86)**
- **Verordnung (EU) Nr. 1 / Commission Regulation (EU) No. 327/2011 (L90, 06.04.11, S. 8-21)**
- **RoHS 2 - restriction of the use of certain hazardous substances 2011/65/EU (L174, 01.07.2011, S. 88-110) incl. (EU) 2015/863**

### Die Geräte/The devices:

Hersteller/Manufacturer: **Pfannenberg GmbH**  
Produkt/Product: **Filterlüfter / Filter Fan**  
Type: **PF 11.000, PF 22.000, PF 32.000, PF 33.000, PF 33.000-SL, PF 42.500, PF 43.000, PF 65.000, PF 65.000-SL, PF 66.000, PF 67.000, PF 67.000-SL, PFA 10.000, PFA 20.000, PFA 30.000, PFA 40.000, PFA 60.000**

wurden entwickelt, konstruiert und gefertigt in Übereinstimmung mit den o.g. EU-Richtlinien, in alleiniger Verantwortung von. were developed, designed and manufactured to comply with the above-mentioned EC directives, under the sole responsibility of:

**Pfannenberg GmbH  
Werner-Witt-Str. 1  
D-21035 Hamburg**

### Folgende harmonisierte Normen wurden angewandt / The following harmonised standards were applicable:

- EN ISO 12100 (2011-03)+Cor. 2013-08 Allgemeine Gestaltungsgrundsätze Risikobeurteilung und Risikominderung (ISO 12100 2010), Deutsche Fassung EN ISO 12100:2010 (Safety of machinery - General principles for design - Risk assessment and risk reduction (ISO 12100 2010), German version EN ISO 12100:2010)
- EN 60335-2-80 (2009-10)+Cor. 2013-03 Sicherheit elektrischer Geräte für den Hausgebrauch und ähnliche Zwecke - Teil 2-80: Besondere Anforderungen für Ventilatoren (IEC 60335-2-80:2002 + A1:2004 + A2:2008), Deutsche Fassung EN 60335-2-80 2003 + A1:2004 + A2:2009 (Household and similar electrical appliances - Safety - Part 2-80: Particular requirements for fans (IEC 60335-2-80 2002 + A1:2004 + A2:2008), German version EN 60335-2-80 2003 + A1:2004 + A2:2009)
- EN 61000-3-2 (2015-03) Elektromagnetische Verträglichkeit (EMV) - Teil 3-2 Grenzwerte - Grenzwerte für Oberschwingungsströme (Geräte-Eingangsstrom  $\leq$  16 A je Leiter) (IEC 61000-3-2:2014), Deutsche Fassung EN 61000-3-2:2014 (Electromagnetic compatibility (EMC) - Part 3-2: Limits - Limits for harmonic current emissions (equipment input current  $\leq$  16 A per phase) (IEC 61000-3-2:2014), German version EN 61000-3-2:2014)
- EN 61000-3-3 (2014-03) Elektromagnetische Verträglichkeit (EMV) - Teil 3-3 Grenzwerte - Begrenzung von Spannungsänderungen, Spannungsschwankungen und Flicker in öffentlichen Niederspannungs-Versorgungsnetzen für Geräte mit einem Bemessungsstrom  $\leq$  16 A je Leiter, die keiner Sonderanschlussbedingung unterliegen (IEC 61000-3-3:2013), Deutsche Fassung EN 61000-3-3 2013 (Electromagnetic compatibility (EMC) - Part 3-3 Limits - Limitation of voltage changes, voltage fluctuations and flicker in public low-voltage supply systems, for equipment with rated current  $\leq$  16 A per phase and not subject to conditional connection (IEC 61000-3-3:2013), German version EN 61000-3-3 2013)
- EN 61000-6-2 (2006-03)+Cor. 2011-06 Elektromagnetische Verträglichkeit (EMV) - Teil 6-2: Fachgrundnormen - Störfestigkeit für Industriebereiche (IEC 61000-6-2:2005), Deutsche Fassung EN 61000-6-2 2005 (Electromagnetic compatibility (EMC) - Part 6-2 Generic standards - Immunity for industrial environments (IEC 61000-6-2 2005), German version EN 61000-6-2:2005)
- EN 61000-6-3 (2011-09)+Cor. 2012-11 Elektromagnetische Verträglichkeit (EMV) - Teil 6-3 Fachgrundnormen - Störaussendung für Wohnbereich, Geschäfts- und Gewerbebereiche sowie Kleinbetriebe (IEC 61000-6-3:2006 + A1 2010), Deutsche Fassung EN 61000-6-3:2007 + A1 2011 (Electromagnetic compatibility (EMC) - Part 6-3 Generic standards - Emission standard for residential, commercial and light-industrial environments (IEC 61000-6-3:2006 + A1 2010), German version EN 61000-6-3:2007 + A1:2011)+Cor. 2012-11
- EN 60529 (2014-09) Schutzarten durch Gehäuse (IP-Codes) (IEC 60529:1989 + A1:1999 + A2:2013), Deutsche Fassung EN 60529:1991 + A1:2000 + A2:2013 (Degrees of protection provided by enclosures (IP Code) (IEC 60529 1989 + A1:1999 + A2 2013), German version EN 60529:1991 + A1:2000 + A2 2013)
- EN 60204-1 (2019-06) Sicherheit von Maschinen - Elektrische Ausrüstung von Maschinen - Teil 1 Allgemeine Anforderungen (IEC 60204-1:2016, modifiziert), Deutsche Fassung EN 60204-1 2018 (Safety of machinery - Electrical equipment of machines - Part 1 General requirements (IEC 60204-1:2016, modified), German version EN 60204-1 2018)
- EN IEC 63000 (2019-05) Technische Dokumentation zur Beurteilung von Elektro- und Elektronikgeräten hinsichtlich der Beschränkung gefährlicher Stoffe (IEC 63000 2016); Deutsche Fassung EN IEC 63000:2018 (Technical documentation for the assessment of electrical and electronic products with respect to the restriction of hazardous substances (IEC 63000:2016), German version EN IEC 63000 2018)

### Folgende nationale Normen, Richtlinien und Spezifikationen wurden angewandt:

The following standards, guidelines and specifications were applicable at national level:

- IEC 60038 (2009-06) IEC-Normspannungen (IEC standard voltages)
- UVV-BGV A3 ( ) Unfallverhütungsvorschrift für Elektrische Anlagen und Betriebsmittel (Accident prevention regulation for electrical systems and machinery)
- ProdSG ( ) Produktsicherheitsgesetz (German law - covering equipment and product safety)

Eine Technische Dokumentation ist beim Hersteller vorhanden, die Montage-/Betriebsanleitung liegt dem Gerät bei. Die Sicherheitshinweise sind zu beachten. Diese Erklärung bescheinigt die Übereinstimmung mit den genannten Richtlinien. The manufacturer is in possession of the technical documentation, the installation/operation instruction is attached to the device. The safety references are to be considered. This explanation certifies the agreement with the guidelines mentioned. Anbringungsjahr / Year of affixing the CE-mark: 06

Hamburg, October-20

Rev No.: 18

P/N 085506618

Nils-Peter Halm

Technischer Leiter / Technical Director