

PROPRIETARY INFORMATION
 NOT TO BE RELEASED
 WITHOUT WRITTEN PERMISSION
 FROM AN AUTHORIZED
 REPRESENTATIVE OF
 APPLIED ENGINEERING PRODUCTS

REVISIONS			
REV.	DESCRIPTION	DATE	APPROVED
A	ECO #6909	11/12/07	D.N.

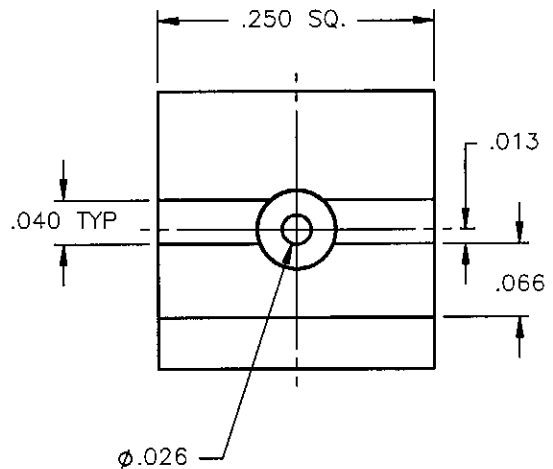
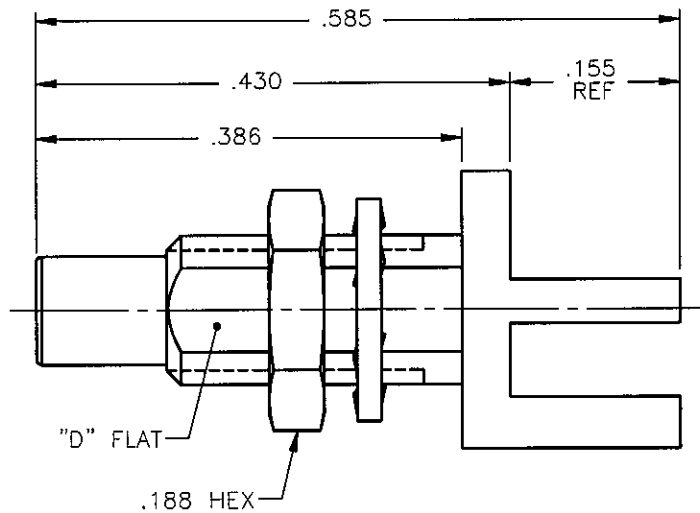

NOTES:

MATERIALS:

1. BODY = STAINLESS STEEL PER ASTM A582, ALLOY 303, CONDITION "A".
2. INSULATOR = VIRGIN WHITE TEFLON PER ASTM D1710, GRADE 1, TYPE I, CLASS "B".
3. CONTACT = BERYLLIUM COPPER PER ASTM B196, ALLOY C17300, TEMPER TD04.
4. LOCKWASHER = PHOSPHOR BRONZE PER ASTM B139, COPPER ALLOY C53400, TEMPER H04.
5. NUT = BRASS PER ASTM B16, ALLOY C36000, TEMPER H02.

FINISHES:

1. BODY = GOLD PLATE PER MIL-G-45204, TYPE II, CLASS 0, GRADE C, OVER .000050 TO .00010 STRESS FREE NICKEL PER QQ-N-290.
2. CONTACT = GOLD PLATE PER MIL-G-45204, TYPE II, CLASS 1, GRADE C, OVER .00010 TO .00020 STRESS FREE SULFAMATE NICKEL PER QQ-N-290.
3. NUT & WASHER = GOLD PLATE PER MIL-G-45204, TYPE II, CLASS 0, GRADE C, OVER .00010 TO .00020 COPPER STRIKE PER MIL-C-14550.

UNLESS OTHERWISE SPECIFIED DIMENSIONS ARE IN INCHES TOLERANCES ON		DWN: D.N.	DATE: 11/12/07	 APPLIED ENGINEERING PRODUCTS 104 John W. Murphy Dr. New Haven, CT 06513 a RADIALL company
DECIMAL	ANGLE	CHKD: A.D.M.	DATE: 11/12/07	
		APVD: J.M.	DATE: 11/12/07	
REFERENCE: ORIGINATED: E.C.C. DATE: 04/07/05		MATERIALS & FINISHES: SEE NOTES		SSMC STRAIGHT MALE JACK BULKHEAD/EDGE MOUNT RECEPTACLE FOR .062 BOARD SIZE: A FSCM NO.: 19505 DWG NO.: 7029-1513-005 SCALE: 6:1 THIRD ANGLE PROJECTION
				REV: A SHEET 1 OF 1

7029-1513-005

Mouser Electronics

Authorized Distributor

Click to View Pricing, Inventory, Delivery & Lifecycle Information:

Radial:

[7029-1513-005](#)