

| REVISIONS | | | |
|-----------|-----------------|----------|----------|
| REV. | DESCRIPTION | DATE | APPROVED |
| A | INITIAL RELEASE | 12/22/09 | A.D.M. |

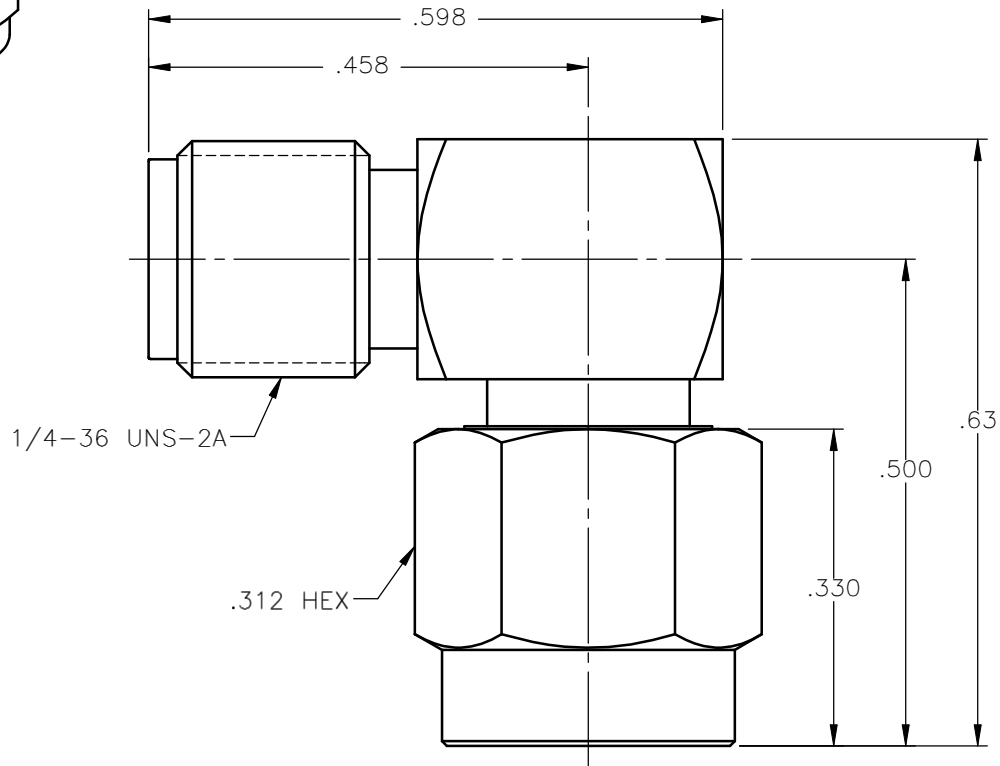

NOTES:

MATERIALS:

1. BODIES & COUPLING NUT = STAINLESS STEEL PER ASTM A582, ALLOY 303, CONDITION "A".
2. INSULATORS = VIRGIN WHITE TEFLON PER ASTM D1710, GRADE 1, TYPE I, CLASS "B".
3. CONTACT & RETAINING RING = BERYLLIUM COPPER PER ASTM B196, ALLOY C17300, TEMPER TD04.
4. CONTACT & CAP = BRASS PER ASTM B16, ALLOY C36000, TEMPER H02.
5. GASKET = SILICONE RUBBER PER ZZ-R-765, CLASS 2B, GRADE 65-75.

FINISHES:

1. BODIES = GOLD PLATE PER MIL-G-45204, TYPE II, CLASS 0, GRADE C, OVER .000050 TO .00010 STRESS FREE NICKEL PER QQ-N-290.
2. CONTACTS = GOLD PLATE PER MIL-G-45204, TYPE II, CLASS 1, GRADE C, OVER .00010 TO .00020 STRESS FREE SULFAMATE NICKEL PER QQ-N-290.
3. CAP = GOLD PLATE PER MIL-G-45204, TYPE II, CLASS 0, GRADE C, OVER .00010 TO .00020 COPPER STRIKE PER MIL-C-14550.
4. COUPLING NUT = PASSIVATE PER QQ-P-35, TYPE VI.

Property of Radiall Incorporated
 This document cannot be reproduced or
 communicated to a third party without prior
 written permission of RADIALL Incorporated.

| | | | | | |
|---|------------------------------------|--|---|--------------------------|--------------|
| UNLESS OTHERWISE SPECIFIED DIMENSIONS ARE IN INCHES TOLERANCES ON | DWN: A.D.M. | DATE 12/22/09 |  APPLIED ENGINEERING PRODUCTS 104 John W. Murphy Dr. New Haven, CT 06513 a RADIALL company | | |
| | CHKD: D.N. | DATE 12/22/09 | | | |
| | APVD: J.M. | DATE 12/22/09 | | | |
| DECIMAL | ANGLE | SMA RIGHT ANGLE PLUG TO JACK ADAPTER | | | |
| REFERENCE: | MATERIALS & FINISHES: SEE NOTES | SIZE A | FSCM NO. 19505 | DWG NO. 5919-1503-000 | REV A |
| ORIGINATED: A.D.M. DATE: 12/22/09 | | SCALE 5:1 | THIRD ANGLE PROJECTION | | SHEET 1 OF 1 |

5919-1503-000

Mouser Electronics

Authorized Distributor

Click to View Pricing, Inventory, Delivery & Lifecycle Information:

Radial:

[5919-1503-000](#)