

| PROD CODE | LOC | DIST | P | F | ZONE | LTR | DESCRIPTION | DATE | APPD |
|-----------|-----|------|---|---|------|-----|--------------------------------|------|------|
| 3321 | DF | XO | | | | K | REV & REDRAWN; 0600-1413-93 CT | 9-94 | JC |

ASSEMBLED VIEW

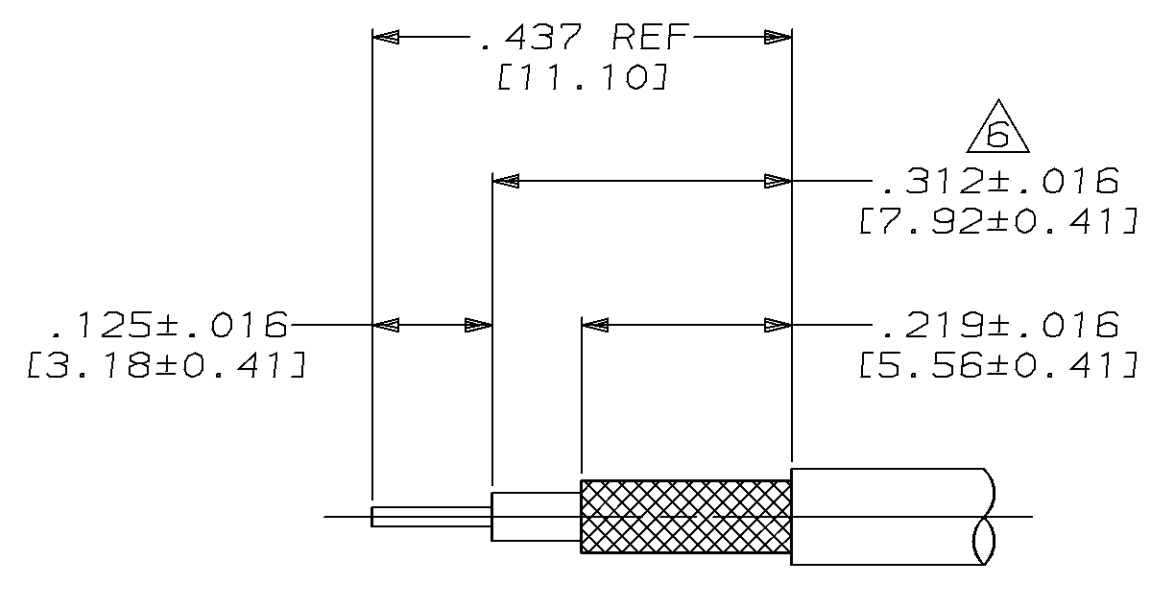

RECOMMENDED STRIP LENGTH
SCALE: N.T.S.

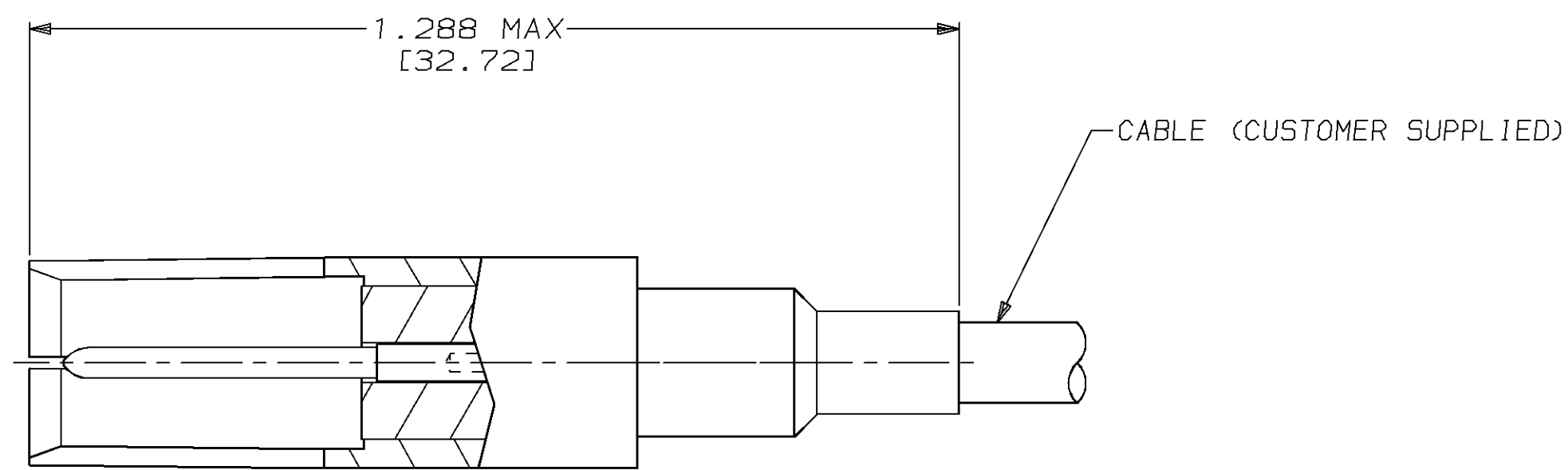
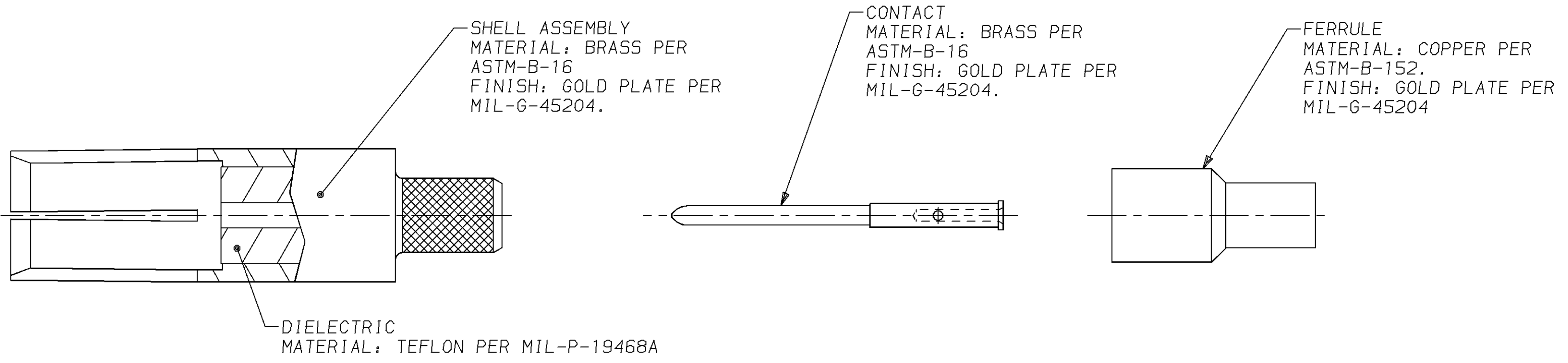

- FOR USE WITH RG-188/U, 188A/u & 316/U COAX CABLE.
 - FERRULE CRIMPING TOOL: AMP TOOL #220066-1 OR 220066-2 OR 220009-1.
 - CONTACT CRIMPING TOOL: M22520/2-01 OR AMP TOOL NUMBER 1-601966-6, SETTING NUMBER 5. DANIELS POSITIONER PART NO. K345 OR AMP TOOL NO. 1-601966-6.
 - SEE I.S.2348.
 - DANIELS MANUFACTURING CORP
2266 FRANKLIN ROAD
BLOOMFIELD HILLS, MI 48013
- △ OUTER JACKET OF CABLE MUST BE TRIMMED TO ALLOW PROPER INTER-PIN CONTACT LOCATION AFTER FERRULE CRIMP OPERATION.
- PARTS SHIPPED UNASSEMBLED AND CABLE IS SUPPLIED BY CUSTOMER.

THIS DRAWING IS A CONTROLLED DOCUMENT FOR AMP INCORPORATED. IT IS SUBJECT TO CHANGE AND THE CONTROLLING ENGINEERING ORGANIZATION SHOULD BE CONTACTED FOR THE LATEST REVISION.

| | | | |
|--|-----------------------------|---|-----------------|
| DO NOT SCALE PRINT. UNLESS SPECIFIED DIMENSIONS IN INCHES [mm] TOLERANCES ON: 2 PLC DEC ± - 3 PLC DEC ± - ANGLES ± - | DR 9-12-94 C.C. THOMAS | AMP Incorporated Harrisburg, PA 17105-3608 | |
| | CHK 9-23-94 J. CABARLO | | |
| MATERIAL SEE CALLOUTS | APPD 9-23-94 J. CABARLO | NAME CONNECTOR, COAXIAL, RF SOCKET SIZE 5, ARINC (HEX CRIMP) | |
| | APPD 9-23-94 C.C. THOMAS | SIZE C 00779 | |
| FINISH SEE CALLOUTS | PRODUCT SPEC 108-12045 | DRAWING NO G=225791-3 | |
| | APPLICATION SPEC - | SCALE 5:1 | SHEET 1 OF 1 |
| WEIGHT - | PART NO. 225791-3 | | |

Mouser Electronics

Authorized Distributor

Click to View Pricing, Inventory, Delivery & Lifecycle Information:

[TE Connectivity:](#)

[225791-3](#)