

Level measurement
in solids

Guided microwave

VEGAFLEX 61 VEGAFLEX 62



Product Information

VEGA

Contents

1 Description of the measuring principle	3
2 Type overview	4
3 Mounting information	7
4 Electrical connection	
4.1 General requirements	10
4.2 Power supply	10
4.3 Connection cable	10
4.4 Connection of the cable screen and grounding	11
4.5 Wiring plans	11
5 Adjustment	
5.1 Adjustment, general	13
5.2 Adjustment with the indicating and adjustment module PLICSCOM	13
5.3 Adjustment with PACTware™	14
6 Technical data	16
7 Dimensions	23
8 Product code	27

Take note of safety instructions for Ex areas



Please note the Ex specific safety information for installation and operation in Ex areas which you will find on our homepage www.vega.com/services/downloads and which come with the appropriate instrument. In hazardous areas you should take note of the appropriate regulations, conformity and type approval certificates of the sensors and power supply units. The sensors must only be operated in intrinsically safe circuits. The permissible electrical values are stated in the certificate.

1 Description of the measuring principle

Measuring principle

High frequency microwave pulses are guided along a steel rope or a rod. When they reach the product surface, the microwave pulses are reflected and received again by the processing electronics. The running time is processed by the instrument.

A microprocessor identifies the level echoes that are measured and evaluated by the ECHOFOX software and converts them into level information.

The time-consuming adjustment with medium is not necessary. The instruments are pre-set to the ordered probe length. The shortenable cable and rod versions can be adapted individually to the local requirements.

Insensitive to dust

Even process conditions such as strong dust generation do not influence the accuracy of the measurement.

Unaffected by material fluctuations

Density fluctuations or changes of the dielectric constant do not influence the accuracy.

Buildup: no problem

Buildup or condensation on the probe or vessel wall do not influence the measuring result.

Wide application range

With measuring ranges of up to 60 m (197 ft), the sensors are best suited for tall vessels. Temperatures of up to 150°C (302°F) and pressures from vacuum up to 40 bar (580 psi) cover a wide application range.

Insensitive to noise

VEGAFLEX sensors are insensitive to filling noise.

2 Type overview

VEGAFLEX 61 with cable electrode



VEGAFLEX 61 with rod electrode



Application:	solids	solids
Measuring range:	0.15 ... 32 m (0.5 ... 105 ft)	0.15 ... 4 m (0.5 ... 13 ft)
Process fitting:	Thread, flange	Thread, flange
Material:	1.4435 (316L) and PCTFE, 1.4401 (316)	1.4435 (316L) and PCTFE, Hastelloy C22 (2.4602)
Process temperature:	-40 ... 150°C (-40 ... 302°F)	-40 ... 150°C (-40 ... 302°F)
Process pressure:	-1 ... 40 bar (-100 ... 4000 kPa/-14.5 ... 580 psi)	-1 ... 40 bar (-100 ... 4000 kPa/-14.5 ... 580 psi)
Signal output:	4 ... 20 mA/HART in two and four-wire technology, Profibus PA, Foundation Fieldbus	4 ... 20 mA/HART in two and four-wire technology, Profibus PA, Foundation Fieldbus

VEGAFLEX 62 with cable electrode**VEGAFLEX 62 with rod electrode**

Application:	solids	solids
Measuring range:	0.15 ... 60 m (0.5 ... 197 ft)	0.15 ... 4 m (0.5 ... 13 ft)
Process fitting:	Thread, flange	Thread, flange
Material:	1.4435 (316L) and PCTFE, 1.4401 (316)	1.4435 (316L) and PCTFE, Hastelloy C22 (2.4602)
Process temperature:	-40 ... 150°C (-40 ... 302°F)	-40 ... 150°C (-40 ... 302°F)
Process pressure:	-1 ... 40 bar (-100 ... 4000 kPa/-14.5 ... 580 psi)	-1 ... 40 bar (-100 ... 4000 kPa/-14.5 ... 580 psi)
Signal output:	4 ... 20 mA/HART in two and four-wire technology, Profibus PA, Foundation Fieldbus	4 ... 20 mA/HART in two and four-wire technology, Profibus PA, Foundation Fieldbus

Indicating and adjustment module



PLICSCOM

Housing



Plastic



Stainless steel



Aluminium



Aluminium
(double chamber)

Electronics



4 ... 20 mA/
HART two-wire



4 ... 20 mA/
HART four-wire



Profibus PA



Foundation
Fieldbus

Process fitting



Thread



Flange

Sensors



Cable electro-
de

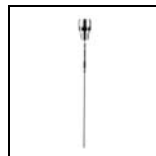

Rod electrode

Approvals



Dust explosion
protection

3 Mounting information

Measuring range

The reference plane of the sensor measuring range is the seal surface of the thread or the lower side of the flange.

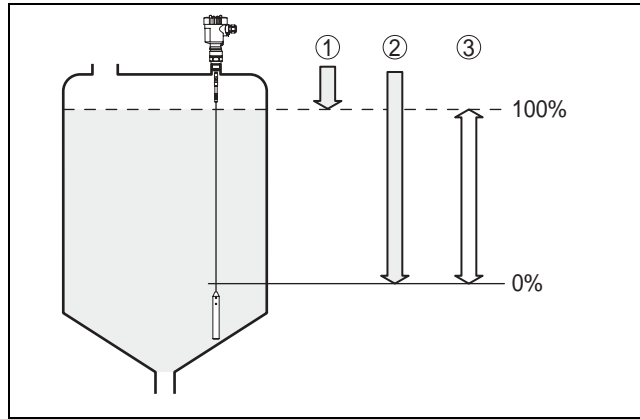

Fig. 1: Measuring range (operating range) and max. measuring distance

- 1 full
- 2 empty (max. measuring distance)
- 3 Measuring range

Keep in mind that a min. distance must be maintained below the reference plane and possibly also at the end of the probe - measurement is not possible in these areas (dead zones). Remember that the entire length of the cable cannot be utilised because it is not possible to measure in the area of the gravity weight. These min. distances (dead zones) are stated in the Technical data in the Supplement.

Pressure/Vacuum

The process fitting must be sealed if there is gauge or low pressure in the vessel. Before use, check if the seal material is resistant to the medium. The max. permissible pressure is stated in the Technical data in the Supplement or on the type label of the sensor.

Installation location

Mount VEGAFLEX in such a way that the probe does not touch any installations or the vessel wall during operation. If necessary, fasten the probe end.

When mounting the cable and rod versions of VEGAFLEX make sure that a distance of at least 300 mm (12 in) to vessel installations or to the vessel wall is maintained.

If possible, mount the sensor flush with the vessel top. If this is not possible, use short sockets with small diameter.

In case of unfavourable mounting conditions such as e.g. very high ($h > 200$ mm / > 8 in) or very wide ($\varnothing > 200$ mm / > 8 in) sockets or a distance to the vessel wall or vessel installations of < 300 mm (< 12 in), we recommend carrying out an empty vessel profile for the area in question. Use the adjustment software PACTware™ with DTM.

Inflowing material

Make sure that the probe is not subjected to strong lateral forces. Mount VEGAFLEX in a location in the vessel where no disturbing influence from e.g. filling openings, agitators, etc. can occur.

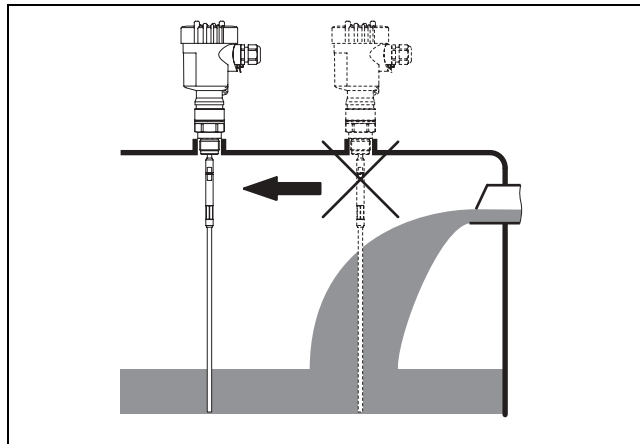

Fig. 2: Lateral load

Vessel type

Plastic vessel

The guided microwave principle requires a metal surface on the process fitting. Therefore use in plastic vessels etc. an instrument version with flange (from DN 50) or place a metal sheet ($\varnothing > 200 \text{ mm} / \varnothing > 8 \text{ in}$) beneath the process fitting when screwing it in.

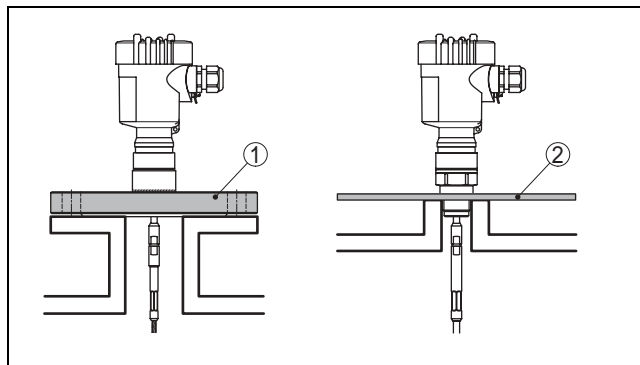

Fig. 3: Installation in plastic silo

- 1 Flange
- 2 Metal plate

Concrete vessel

When installing in thick concrete ceilings, VEGAFLEX should be mounted flush with the lower edge. In concrete silos, the distance to the wall should be at least 500 mm (20 in).

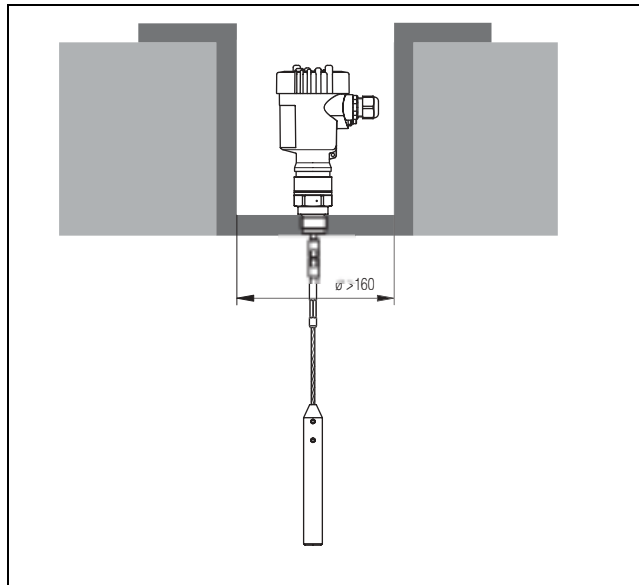

Fig. 4: Installation in concrete silos

Fasten

If there is the danger of the probe touching the vessel wall during operation, e.g. due to product movement or the influence of agitators, it should be secured.

There is a thread (M12) in the gravity weight for fastening, e.g. an eyebolt (article no. 2.27423).

Make sure that the probe cable is not overly taut. Avoid tensile loads on the cable. Use a slightly pre-stressed tension spring to fasten the cable.

Avoid undefined cable-vessel connections, i.e. the connection must be either reliably grounded or reliably insulated. Any deviation from this requirement will lead to measurement errors.

4 Electrical connection

4.1 General requirements

The power supply range can differ depending on the instrument version. You will find detailed information in the Technical data.

Take note of country-specific installation standards (e.g. the VDE regulations in Germany) as well as all prevailing safety regulations and accident prevention rules.



In hazardous areas you should take note of the appropriate regulations, conformity and type approval certificates of the sensors and power supply units.

4.2 Power supply

4 ... 20 mA/HART two-wire

Power supply and current signal are carried over the same two-wire connection cable. The requirements on the power supply are stated in the Technical data of this Product Information manual.

The VEGA power supply units VEGATRENN 149AEx, VEGASTAB 690, VEGADIS 371 as well as the VEGAMET signal conditioning instruments are suitable for power supply. When one of these instruments is used, a reliable separation of the supply circuit from the mains circuits acc. to DIN VDE 0106 part 101 and protection class is ensured.

4 ... 20 mA/HART four-wire

Power supply and signal current are carried on two separate connection cables.

The standard version can be operated with an earth-connected current output, the Exd version must be operated with a floating output.

The instrument is designed in protection class I. To maintain this protection class, it is absolutely necessary that the ground conductor be connected to the internal ground conductor terminal.

Profibus PA

The power supply is provided via a Profibus DP/PA segment coupler or a VEGALOG 571 EP input card.

Foundation Fieldbus FF

Power supply via the H1 Fieldbus cable.

4.3 Connection cable

General

An outer cable diameter of 5 ... 9 mm ensures the seal effect of the cable entry. If electromagnetic interference is expected, we recommend the use of screened cable for the signal lines.

The sensors are connected with standard two-wire cable without screen.

Profibus PA/Foundation Fieldbus

The installation must be carried out acc. to the appropriate bus specification. VEGA-FLEX is connected with screened cable acc. to the bus specification. Make sure that the bus is terminated via appropriate terminating resistors.

An approved installation cable with PE conductor is also required for power supply.



In Ex applications, the corresponding installation regulations for the connection cable must be noted.

4.4 Connection of the cable screen and grounding

The cable screen must be connected on both ends to ground potential.

If potential equalisation currents are expected, the connection on the evaluation side must be made via a ceramic capacitor (e.g. 1 nF, 1500 V).

Profibus PA/Foundation Fieldbus FF

In systems with potential equalisation, connect the cable screen at the power supply unit, in the connection box and at the sensor directly to ground potential.

In systems without potential equalisation, connect the cable screen directly to ground potential only at the power supply unit and at the sensor - do not connect to ground potential in the connection box or the T-distributor.

4.5 Wiring plans

Single chamber housing

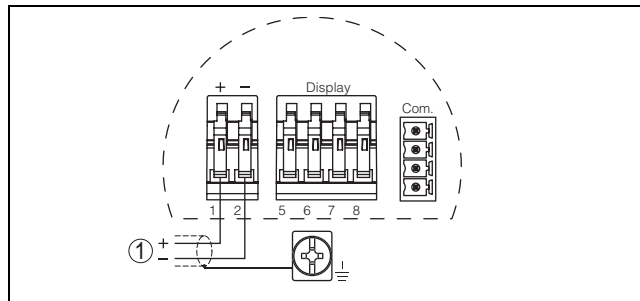

Fig. 5: Connection HART two-wire, Profibus PA, Foundation Fieldbus

1 Power supply and signal output

Double chamber housing - two-wire

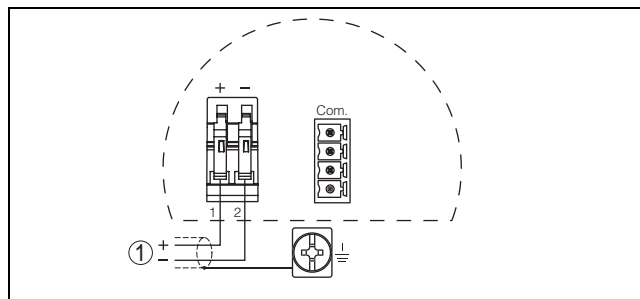

Fig. 6: Connection HART, Profibus PA, Foundation Fieldbus two-wire

1 Power supply and signal output

Double chamber housing - 4 ... 20 mA/HART four-wire

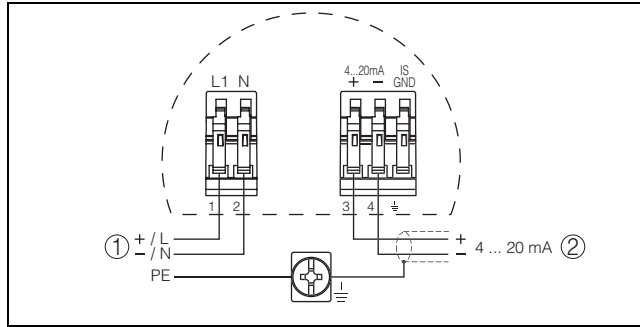

Fig. 7: Connection 4 ... 20 mA/HART four-wire

- 1 Voltage supply
- 2 Signal output

5 Adjustment

5.1 Adjustment, general

Depending on the electronics version, VEGAFLEX can be set up and operated with the following adjustment media:

- the indicating and adjustment module PLICSCOM
- an adjustment software acc. to FDT/DTM standard, e.g. PACTware™ and PC
- a HART handheld (4 ... 20 mA/HART)
- a configuration tool (Foundation Fieldbus)
- the Simatic adjustment program PDM (Profibus PA)

The entered parameters are generally saved in VEGAFLEX, optionally also in PLICSCOM or in PACTware™.

5.2 Adjustment with the indicating and adjustment module PLICSCOM

Setup and indication

PLICSCOM is a pluggable indicating and adjustment module for plics® sensors. It can be placed in four different positions on the instrument (each displaced by 90°). Indication and adjustment are carried out via four keys and a clear, graphic-capable dot matrix display. The adjustment menu with language selection is clearly structured and enables easy setup. After adjustment, PLICSCOM serves as indicating instrument - via the screwed cover with glass insert, the measured values can be read directly in the requested unit and presentation.

PLICSCOM adjustment

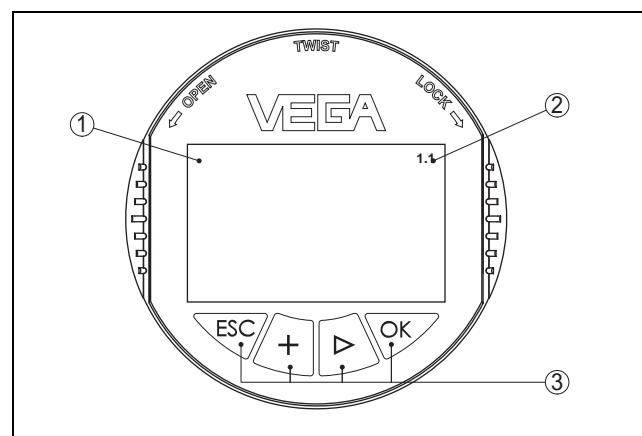

Fig. 8: Indicating and adjustment elements

- 1 LC display
- 2 Indication of the menu item number
- 3 Adjustment keys

Key functions

- **[OK]** key:
 - move to the menu overview
 - confirm selected menu
 - edit parameter
 - save value
- **[→]** key to select:
 - menu change
 - list entry
 - editing position
- **[+]** key:

- modify value of a parameter
- **[ESC]** key:
 - interrupt input
 - jump to the next higher menu

5.3 Adjustment with PACTware™

PACTware™/DTM

Independent of the respective signal output, whether 4 ... 20 mA/HART, Profibus PA oder Foundation Fieldbus, VEGAFLEX sensors can be adjusted directly on the instrument via PACTware™. To adjust with PACTware™ an appropriate instrument driver is required for VEGAFLEX.

All currently available VEGA DTMs are provided in a DTM Collection with the current PACTware™ version on CD. They are available from the responsible VEGA agency for a token fee. The basic version of this DTM Collection incl. PACTware™ is also available as a free-of-charge download from the Internet.

To use the entire range of functions of the DTM incl. project documentation, a DTM licence for that particular instrument family, e.g. VEGAFLEX, is required. This licence can be bought from the responsible VEGA agency.

Connecting the PC directly to the sensor

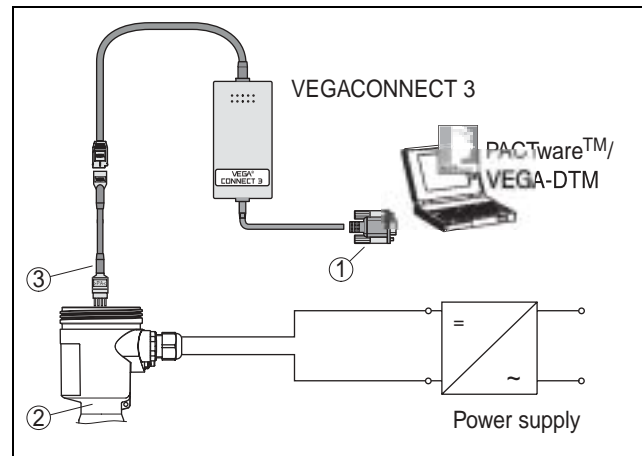

Fig. 9: PC connected directly to the sensor

- 1 RS232 connection
- 2 VEGAFLEX
- 3 I²C adapter cable for VEGACONNECT 3

To adjust with PACTware™, a VEGACONNECT 3 with I²C adapter cable (art. no. 2.27323) as well as a power supply unit is required in addition to the PC and the suitable VEGA DTM.

Connecting the PC to the signal cable (4 ... 20 mA/HART)

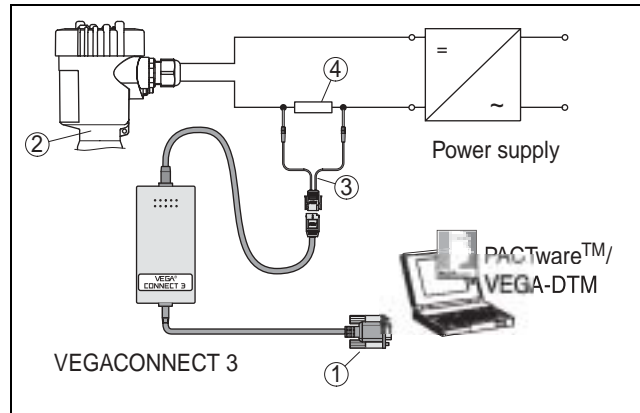

Fig. 10: Connecting the PC to the signal cable

- 1 RS232 connection
- 2 VEGAFLEX
- 3 HART adapter cable for VEGACONNECT 3
- 4 HART resistance 250 Ohm

To adjust with PACTware™, a VEGACONNECT 3 with I²C adapter cable (art. no. 2.27323) as well as a power supply unit is required in addition to the PC is required in addition to the PC and the suitable VEGA DTM.



Note:

With power supply units with integrated HART resistance (internal resistance approx. 250 Ohm), an additional external resistance is not necessary (e.g. VEGATRENN 149A, VEGADIS 371, VEGAMET 381/624/625, VEGASCAN 693). In these cases, VEGACONNECT can be connected in parallel to the 4 ... 20 mA cable.

6 Technical data

General data

Materials, wetted parts

VEGAFLEX 61	
– process fitting - cable version	1.4435 (316L) and PCTFE
– process fitting - rod version	1.4435 (316L) and PCTFE, Hastelloy C22 (2.4602) and PCTFE
– cable (ø 4 mm/ø 0.16 in)	1.4401 (316)
– rod (ø 6 mm/ø 0.24 in)	1.4435 (316L), Hastelloy C22 (2.4602)
– seal	Viton, Kalrez 6375, EPDM, Viton FEP-coated

VEGAFLEX 62

– process fitting - cable version	1.4435 (316L) and PTFE
– process fitting - rod version	1.4435 (316L) and PCTFE, Hastelloy C22 (2.4602) and PTFE
– cable (ø 6 mm / ø 0.24 in)	1.4401 (316)
– rod (ø 16 mm/ø 0.63 in)	1.4435 (316L), Hastelloy C22 (2.4602)
– seal	Viton, Kalrez 6375, EPDM, Viton FEP-coated

Materials - non-wetted parts

Materials, non-wetted parts

– housing	plastic PBT (Polyester), Alu-die casting powder-coated, stainless steel (316L)
– seal between housing and housing cover	NBR (stainless steel housing), silicone (Alu/plastic housing)
– inspection window in housing cover for PLICSCOM (option)	Polycarbonate
– ground terminal	stainless steel 1.4571(316Ti)/1.4435 (316L)

Weights

Weights - VEGAFLEX 61

– plastic housing	760 g (27 oz)
– Aluminium housing	1170 g (41 oz)
– Aluminium double chamber housing	1470 g (52 oz)
– Stainless steel housing	1530 g (54 oz)
– cable (ø 4 mm/ø 0.16 in)	approx. 80 g/m (0.9 oz/ft)
– rod (ø 6 mm/ø 0.24 in)	approx. 220 g/m (2.4 oz/ft)
– gravity weight (only with cable version)	approx. 325 g (11.5 oz)

Weights - VEGAFLEX 62

– plastic housing	1580 g (56 oz)
– Aluminium housing	2000 g (70 oz)
– Aluminium double chamber housing	2300 g (81 oz)
– stainless steel housing	2350 g (83 oz)
– cable (ø 6 mm / ø 0.24 in)	approx. 170 g/m (1.9 oz/ft)
– rod (ø 16 mm/ø 0.63 in)	approx. 1600 g/m (18 oz/ft)
– gravity weight (only with cable version)	approx. 730 g (26 oz)

Lengths

Lengths (L)

– cable (ø 4, ø 6 mm/ø 0.16, ø 0.24 in)	1 ... 32 m (3 ... 105 ft)
– cable (ø 6 mm / ø 0.24 in)	1 ... 60 m (3 ... 197 ft)
– rod (ø 6, ø 16 mm/ø 0.24, ø 0.63 in)	0.5 ... 4 m (1.7 ... 13 ft)

Lateral load

Lateral load

– rod (ø 6 mm/ø 0.24 in)	4 Nm (3 lbf ft)
– rod (ø 16 mm/ø 0.63 in)	30 Nm (22 lbf ft)

Max. tensile load	Max. tensile load	
	– VEGAFLEX 61 (cable- \varnothing 4 mm/ \varnothing 0.16 in)	5 KN
	– VEGAFLEX 62 (cable- \varnothing 6 mm/ \varnothing 0.24 in)	30 KN
Output variable		
4 ... 20 mA/HART	Output signal	4 ... 20 mA/HART
	Resolution	1.6 μ A
	Fault signal	current output unchanged, 20.5 mA, 22 mA, < 3.6 mA (adjustable)
	Current limitation	22 mA
	Load	
	– four-wire sensor	max. 500 Ohm ¹⁾
	– two-wire sensor	see load diagram in Power supply
	Integration time	0 ... 999 s, adjustable
	Fulfilled Namur recommendation	NE 43
Profibus PA	Output signal	digital output signal, format acc. to IEEE-754
	– sensor address	126 (default setting)
	Current value	constantly 10 mA \pm 0.5 mA
	Integration time	0 ... 999 s, adjustable
Foundation Fieldbus FF	Output	
	– signal	digital output signal, Foundation Fieldbus protocol
	– physical layer	acc. to IEC 1158-2
	Channel Numbers	
	– channel 1	Primary Value
	– channel 2	Secondary Value 1
	– channel 3	Secondary Value 2
	– channel 4	Temperature Value ²⁾
	Current value	10 mA \pm 0.5 mA
Input variable		
cable and rod version	Parameter	level of liquids
	Min. dielectric figure - rod, cable version	Er >1.7
	Dead zone - rod version (\varnothing 6, \varnothing 16 mm/ \varnothing 0.24, \varnothing 0.63 in)	
	– top	120 mm (4.7 in)
	– bottom	-

¹⁾ With inductive load, ohmic share at least 25 Ohm/mH.

²⁾ Only with sensors with integrated temperature measurement.

Dead zone - cable version (ø 4, ø 6 mm/ø 0.16, ø 0.24 in)

- top 150 mm (5.9 in)
- bottom 250 mm (9.8 in) (gravity weight + 100 mm)

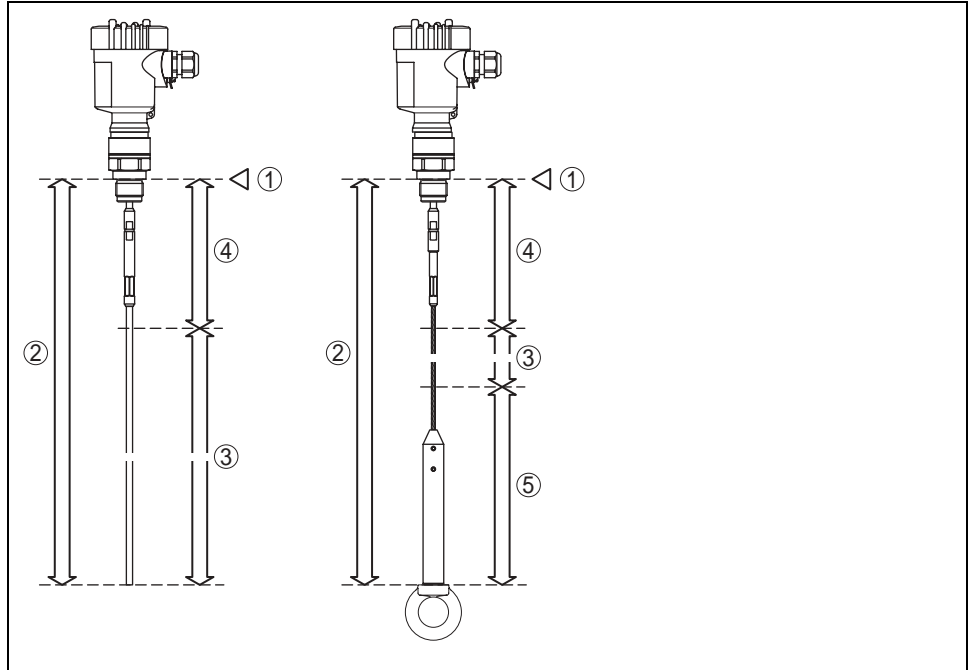

Fig. 11: Meas. ranges of VEGAFLEX - rod and cable version e.g. VEGAFLEX 61

- 1 Reference plane
- 2 Probe length
- 3 Measuring range
- 4 Upper dead zone
- 5 Lower dead zone (only with cable version)

Accuracy (similar to DIN EN 60770-1)

Reference conditions acc. to DIN EN 61298-1

- temperature 18 ... 30°C (64 ... 86°F)
- relative humidity 45 ... 75 %
- pressure 860 ... 1060 mbar (86 ... 106 kPa or 12.5 ... 15 psi)

Characteristics curve deviation and measurement characteristics

Reference installation conditions

- flange DN 100
- min. distance to installations 1 m (3.3 ft)
- min. distance to the metal vessel bottom 20 mm (0.8 in)

Reference reflector

metal plate ø 500 mm (20 in)

Temperature drift (current output)

0.06 %/10 K relating to the max. measuring range

Accuracy

- cable version ±5 mm (±0.2 in)
- rod version ±5 mm (±0.2 in)

Ambient conditions

Ambient, storage and transport temperature

- without PLICSCOM -40 ... +80°C (-40 ... +176°F)
- with PLICSCOM -20 ... +70°C (-4 ... +158°F)
- IP 68 version with PE connection cable -40 ... +60°C (-40 ... +140°F)

Process conditions

Process pressure -1 ... 40 bar (-100 ... 4000 kPa/-14.5 ... 580 psi) depending on the process fitting

Process temperature (thread or flange temperature)

- Viton -30 ... 150°C (-22 ... 302°F)
- Viton, FEP coated -40 ... 150°C (-40 ... 302°F)
- EPDM -40 ... 150°C (-40 ... 302°F)
- Kalrez 6375 -20 ... 150°C (-4 ... 302°F)

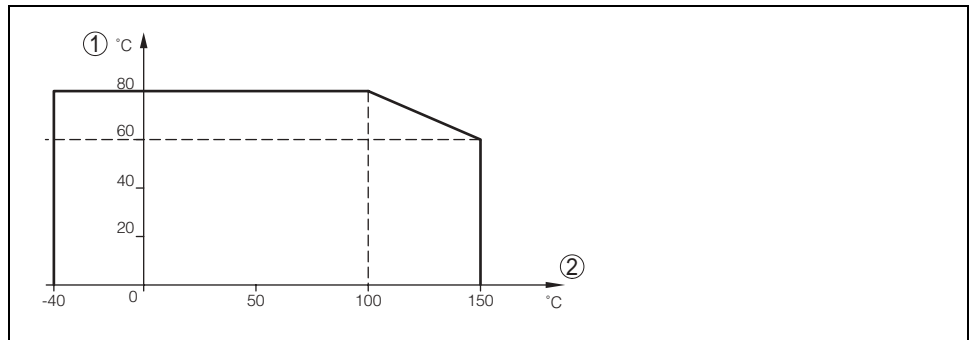

Fig. 12: VEGAFLEX - Ambient temperature - Product temperature

- 1 Ambient temperature
- 2 Product temperature (dependent on the seal material)

Electromechanical data

Cable entry/plug (dependent on the version)

– single chamber housing

- 1 x cable entry M20x1.5 (cable-ø 5 ... 9 mm), 1 x blind stopper M20x1.5

or:

- 1 x closing cap ½ NPT, 1 x blind stopper ½ NPT

or:

- 1 x plug M12x1, 1 x blind stopper M20x1.5

– double chamber housing

- 1 x cable entry M20x1.5 (cable-ø 5 ... 9 mm), 1 x blind stopper M20x1.5, plug M12x1 for VEGADIS 61 (option)

or:

- 1 x closing cap ½ NPT, 1 x blind stopper ½ NPT, plug M12x1 for VEGADIS 61 (option)

or:

- 1 x plug M12x1, 1 x blind stopper M20x1.5, plug M12x1 for VEGADIS 61 (option)

Spring-loaded terminals

for wire cross sections up to 2.5 mm²

Indicating and adjustment module PLICSCOM

Power supply and data transmission

through sensor via gold-plated sliding contacts (I²C bus)

Display

LC display in full dot matrix

Adjustment elements

4 keys

Protection

– unassembled

IP 20

– mounted into the sensor without cover

IP 40

Materials

– housing

ABS

– inspection window

Polyester foil

Power supply VEGAFLEX - two-wire instrument

4 ... 20 mA/HART

Supply voltage

– non-Ex instrument

14 ... 36 V DC

– EEx ia instrument

14 ... 30 V DC

– EExd ia instrument

20 ... 36 V DC

Permissible residual ripple

– < 100 Hz

U_{ss} < 1 V

– 100 Hz ... 10 kHz

U_{ss} < 10 mV

Load

see diagram

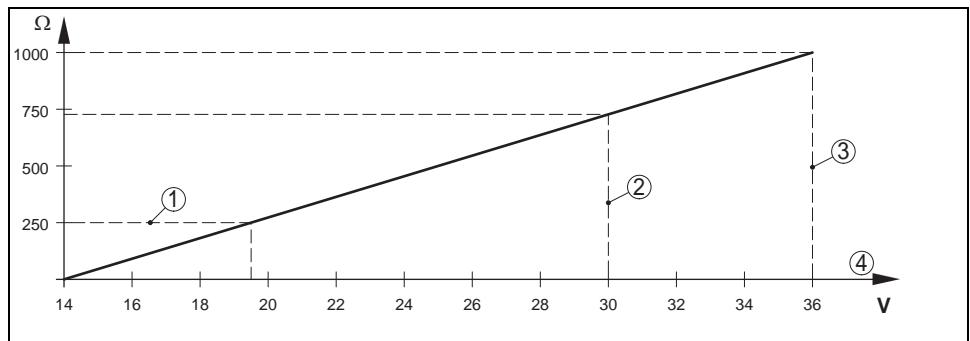

Fig. 13: Voltage diagram

- 1 HART load
- 2 Voltage limit EEx ia instrument
- 3 Voltage limit non-Ex instrument/Exd instrument
- 4 Supply voltage

Profibus PA

Supply voltage
 – non-Ex instrument 9 ... 32 V DC
 – EEx ia instrument 9 ... 24 V DC

Power supply by/max. number of sensors
 – DP/PA segment coupler max. 32 (max. 10 with Ex)
 – VEGALOG 571 EP card max. 15 (max. 10 with Ex)

Foundation Fieldbus FF

Supply voltage
 – non-Ex instrument 9 ... 32 V DC
 – EEx ia instrument 9 ... 24 V DC

Power supply by/max. number of sensors
 – H1 fieldbus cable/Power supply max. 32 (max. 10 with Ex)

Power supply VEGAFLEX - four-wire instrument 4 ... 20 mA

Four-wire instruments

Supply voltage
 – non-Ex and EEx d instrument 20 ... 72 V DC, 20 ... 253 V AC, 50/60 Hz
 Power consumption max. 4 VA, 2.1 W

Electrical protective measures

Protection IP 66/67
 Overvoltage category III
 Protection class
 – two-wire, Profibus PA, Foundation Fieldbus II
 – four-wire I

Approvals³⁾

ATEX II 1G, 1/2G, 2G EEx ia IIC T6,

ATEX II 1/2G, 2G EEx d ia IIC T6

Ship approvals

WHG

CE conformity

EMVG (89/336/EWG), Emission

EN 61326: 1997 (class B), Susceptibility

EN 61326: 1997/A1: 1998

NSR (73/23/EWG), EN 61010-1: 2001.

Namur recommendation NE 21

³⁾ Deviating data with Ex applications: see separate safety instructions.

7 Dimensions

Housing

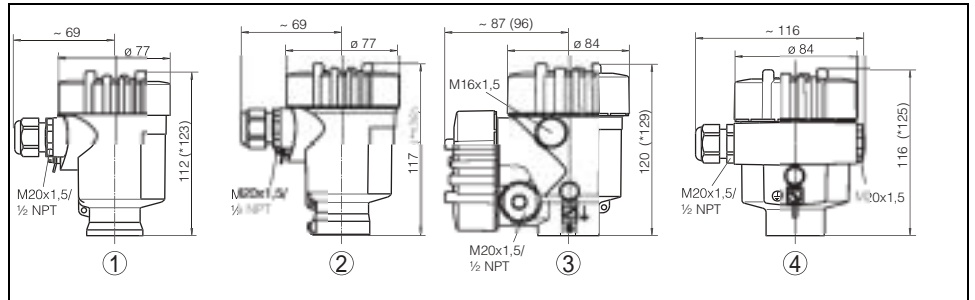

Fig. 14: Housing versions

- 1 Plastic housing (* dimension with integrated PLICSCOM)
- 2 Stainless steel housing (* dimension with integrated PLICSCOM)
- 3 Aluminium double chamber housing (* dimension with integrated PLICSCOM)
- 4 Aluminium housing (* dimension with integrated PLICSCOM)

VEGAFLEX 61 - Rod and cable version

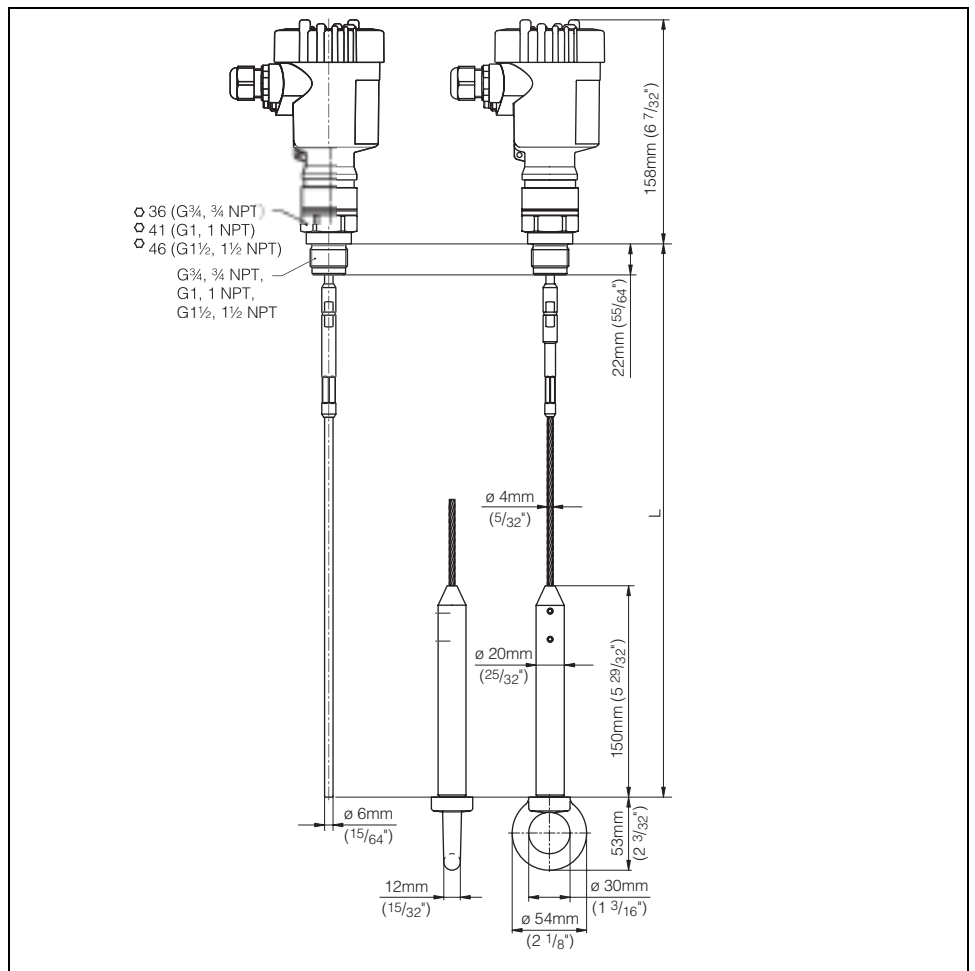

Fig. 15: VEGAFLEX 61 - Cable and rod version with thread

L = Sensor length, see Technical data

VEGAFLEX 61 - Rod and cable version

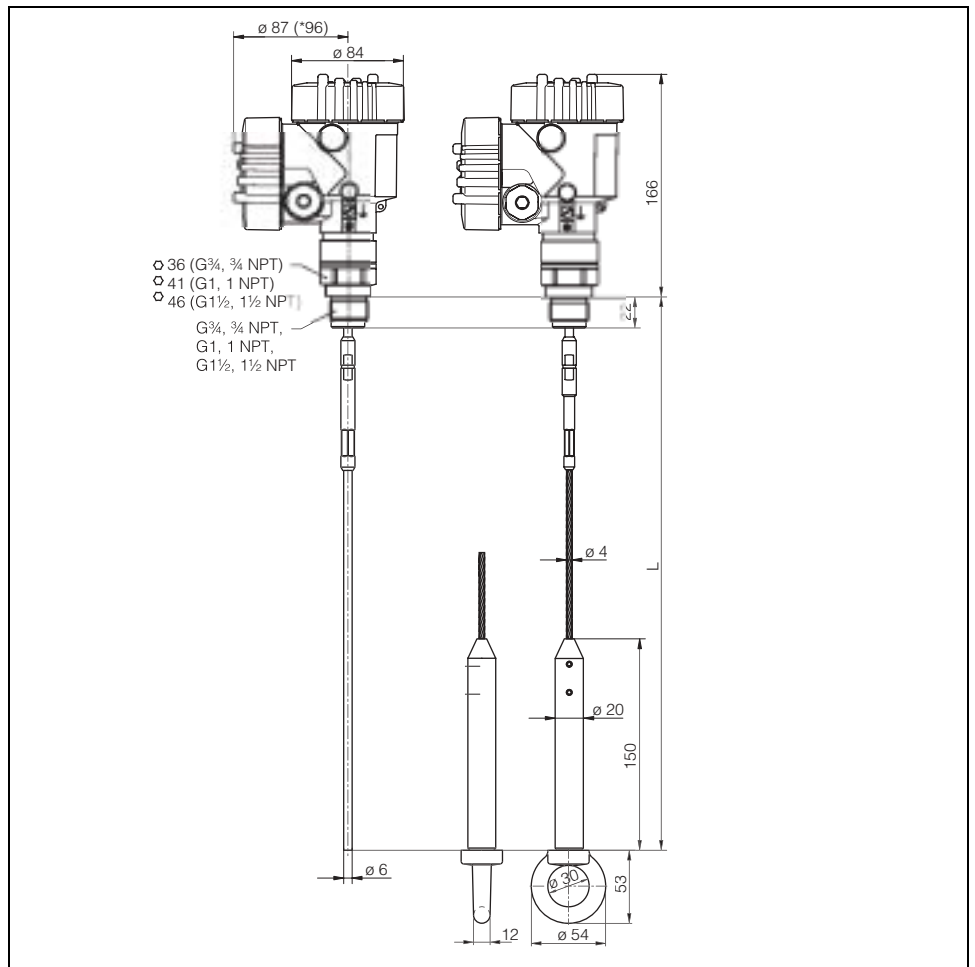

Fig. 16: VEGAFLEX 61 - Cable and rod version with thread (double chamber housing)

L = Sensor length, see Technical data

VEGAFLEX 62 - Rod and cable version

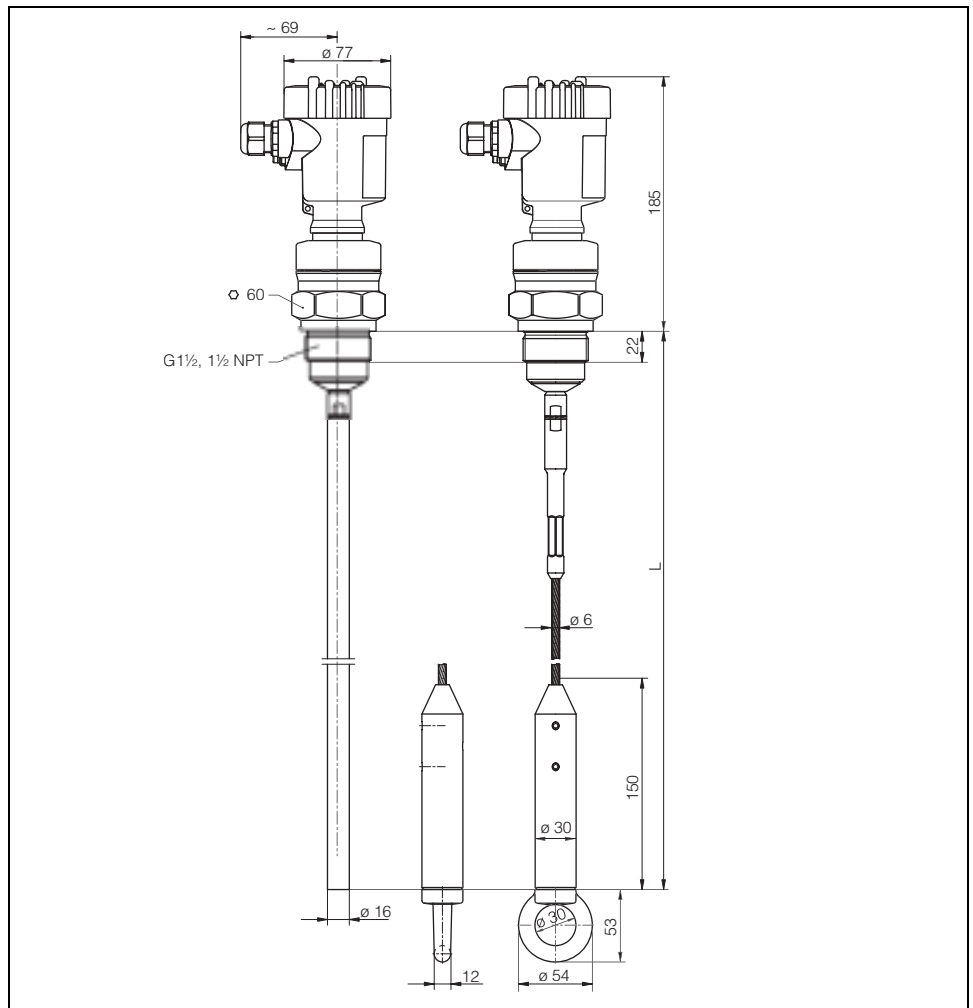

Fig. 17: VEGAFLEX 62 - Cable and rod version with thread

L = Sensor length, see Technical data

VEGAFLEX 62 - Rod and cable version

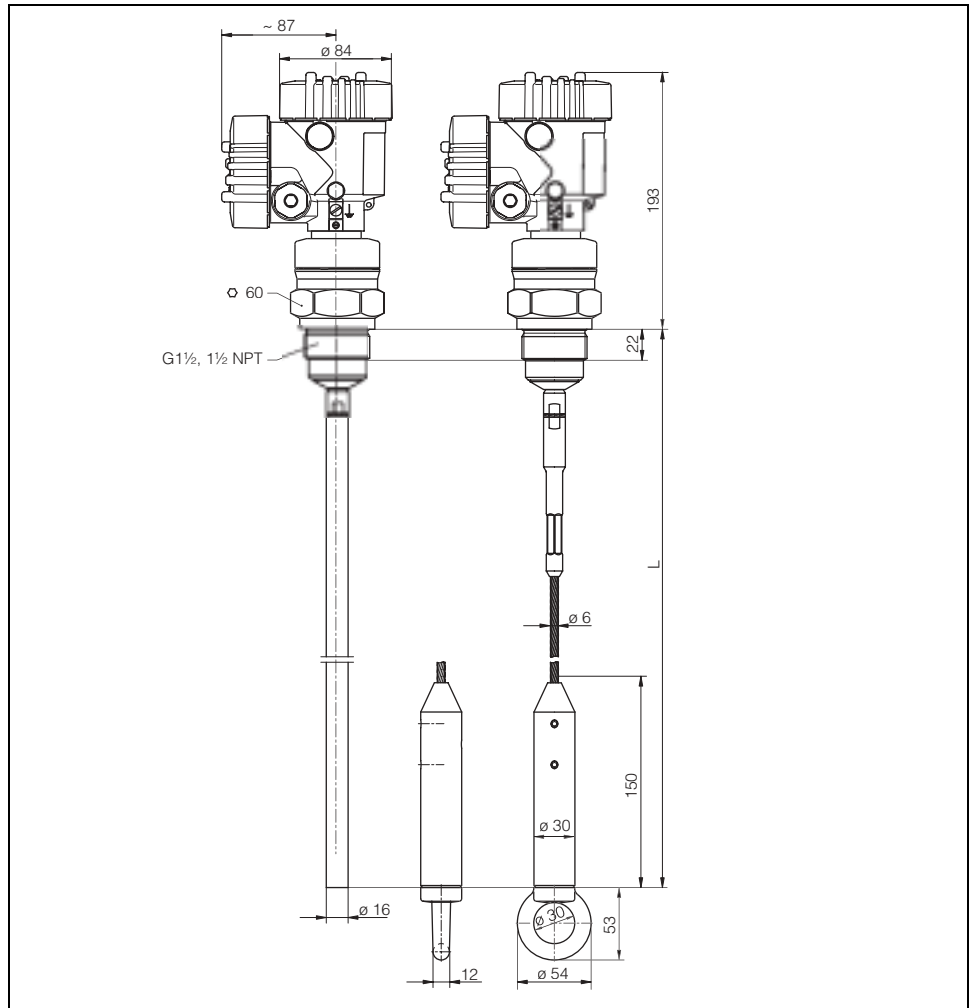

Fig. 18: VEGAFLEX 62 - Cable and rod version with thread (double chamber housing)

L = Sensor length, see Technical data

8 Product code

**Information:**

The product codes shown here are only an excerpt from the list of all possible product versions. You will find detailed information in the VEGA product catalogue or under www.vega.com.



VEGA

VEGA Grieshaber KG
Am Hohenstein 113
77761 Schiltach
Germany
Phone +49 7836 50-0
Fax +49 7836 50-201
E-Mail: info@de.vega.com
www.vega.com



You can find at www.vega.com downloads of the following

- operating instructions manuals
- menu schematics
- software
- certificates
- approvals

and much, much more