

Customer Information Sheet

DRAWING No.: S0961-46R

SHEET 2 OF 2

IF IN DOUBT - ASK

©

NOT TO SCALE

THIRD ANGLE PROJECTION

ALL DIMENSIONS IN mm

SPECIFICATION:

- MATERIAL:**
CONTACT = STAINLESS STEEL, 0.15mm THICK
- FINISH:**
1.0µm - 3.0µm TIN OVER 0.4µm - 1.5µm NICKEL
- ELECTRICAL:**
RESISTANCE = 100mΩ MAX
- MECHANICAL:**
INSERTION FORCE = 24.5N MAX
WITHDRAWAL FORCE = 0.98N MIN
DURABILITY = 10 CYCLES
- ENVIRONMENTAL:**
OPERATING TEMPERATURE = -40°C TO +85°C
STORAGE TEMPERATURE = -40°C TO +85°C
- SOLDERING DATA:**
SOLDERING HEAT RESISTANCE = 250°C FOR 5 SECONDS

NOTES:

- FOR USE WITH 0.15 - 0.20mm THICK SHIELD CANS.
- QUANTITY PER REEL = 10,000.

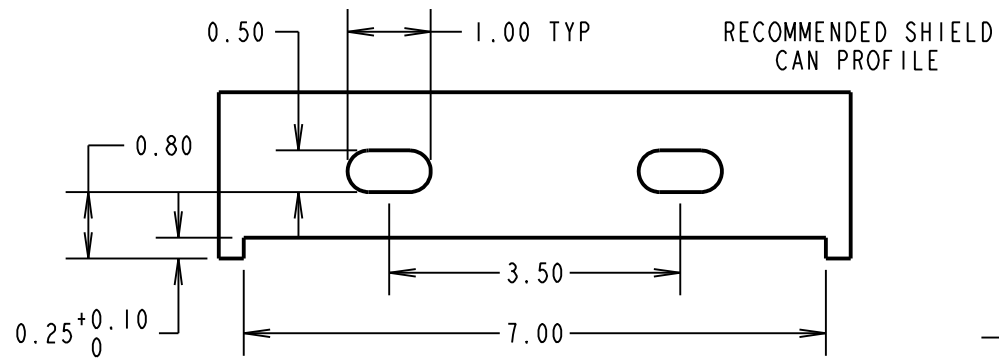
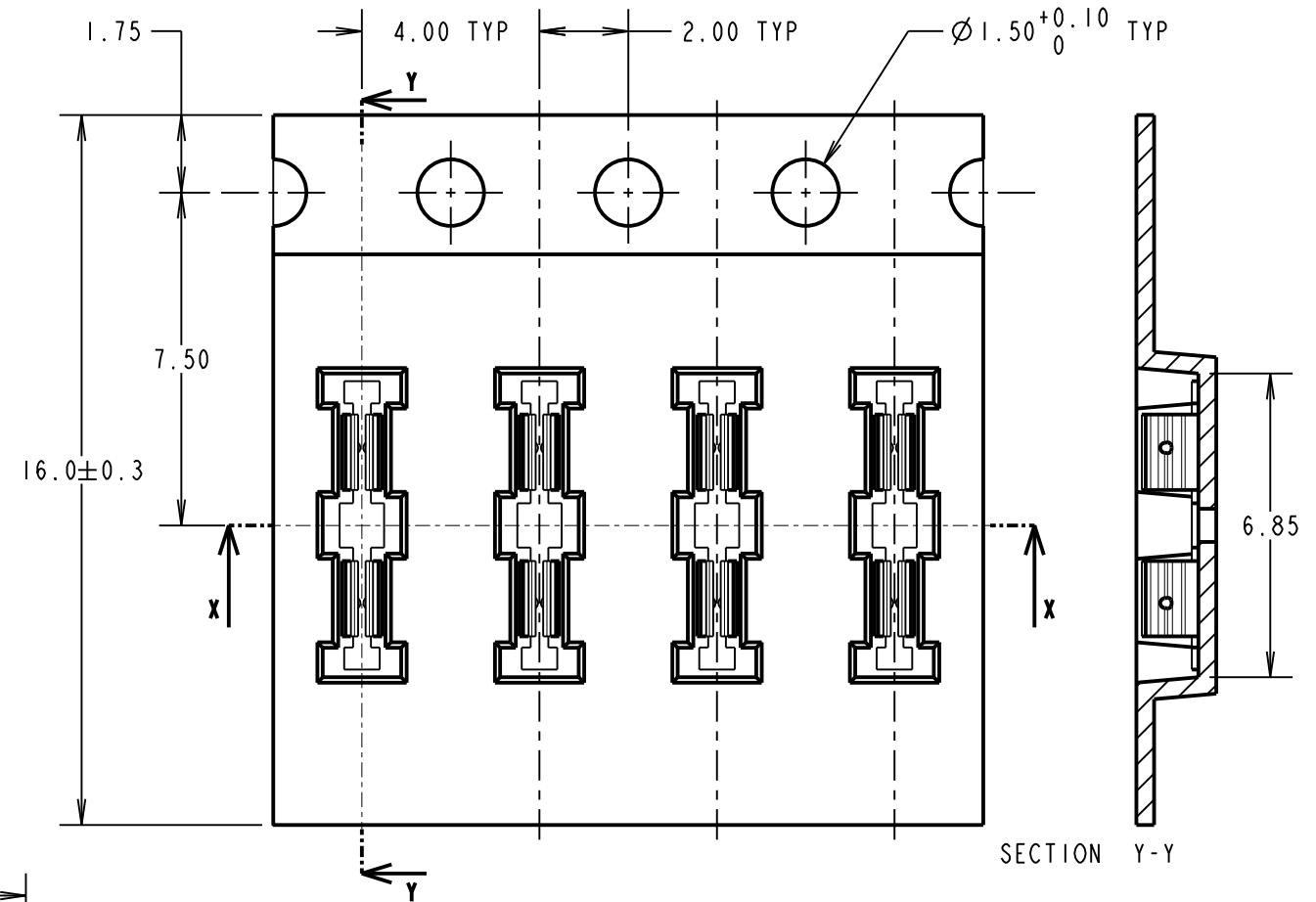
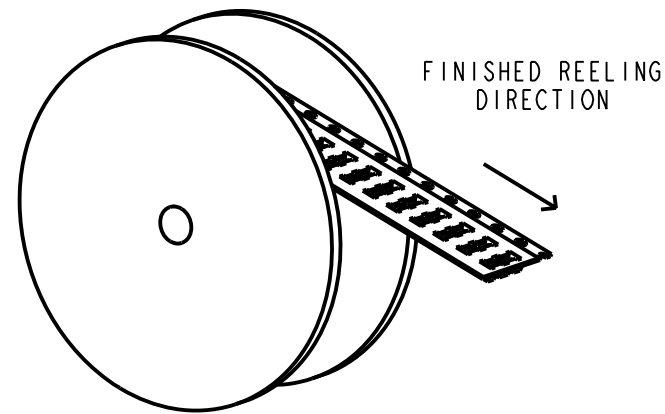

RECOMMENDED PCB LAYOUT (TOLERANCE = ±0.05)

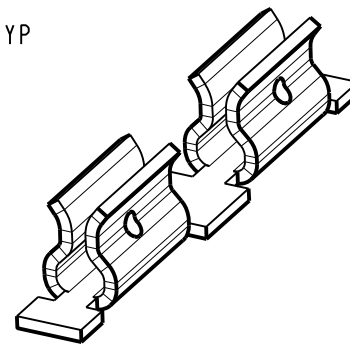
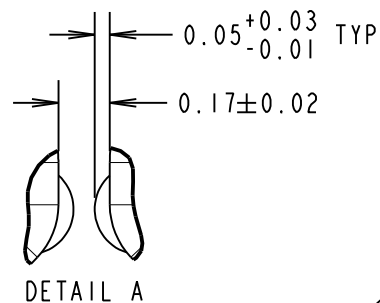
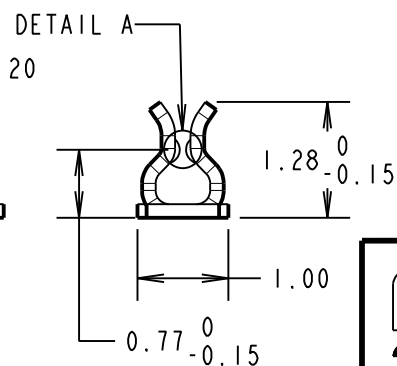
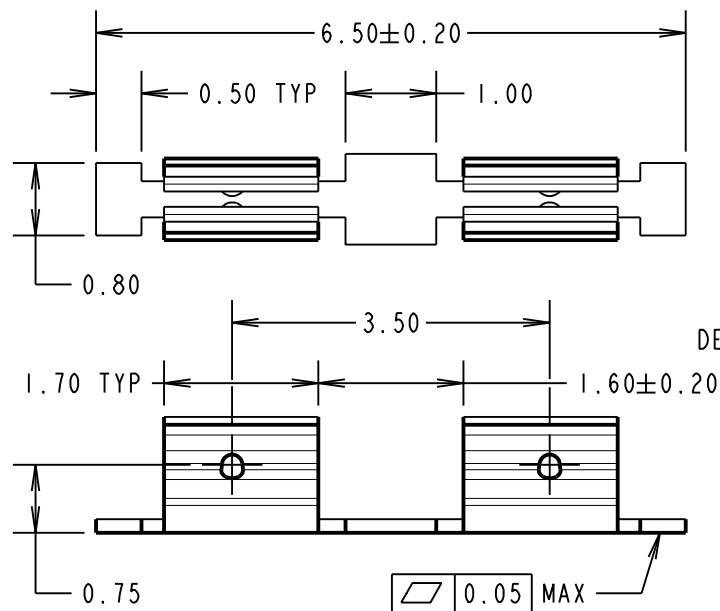
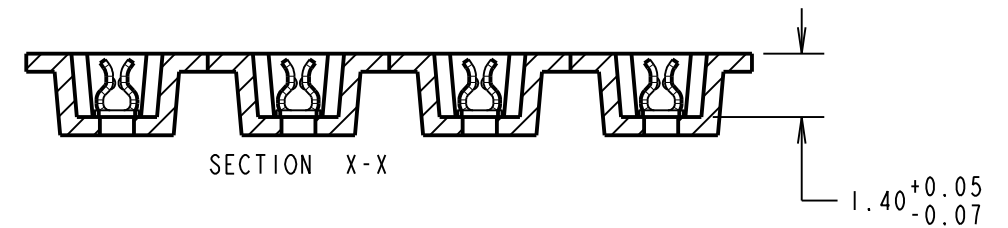
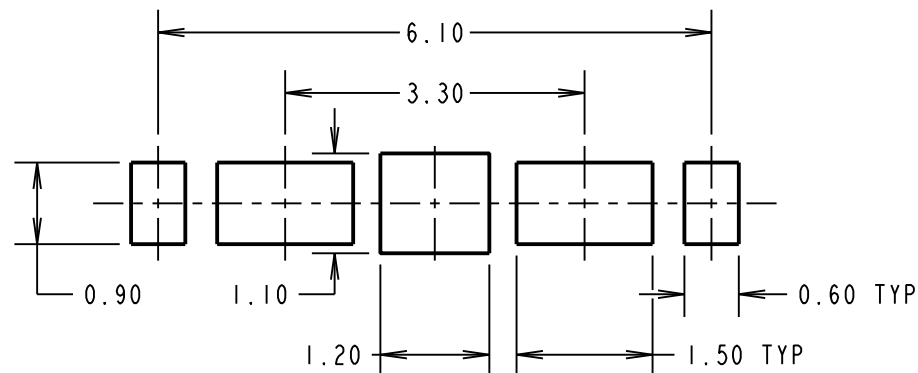

REEL DETAILS

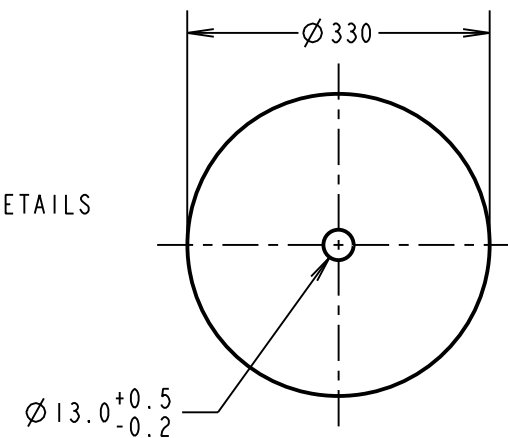

SB	4	01.11.17	20875
NAME	ISS.	DATE	C/NOTE
APPROVED:		S.BENNETT	
CHECKED:		M.PLESTED	
DRAWN:		S.BENNETT	
CUSTOMER REF.:			
ASSEMBLY DRG:			

HARWIN

www.harwin.com
technical@harwin.com

THIS DRAWING AND ANY INFORMATION OR DESCRIPTIVE MATTER SET OUT HEREON ARE CONFIDENTIAL AND COPYRIGHT PROPERTY OF THE HARWIN GROUP AND MUST NOT BE DISCLOSED, LOANED, COPIED OR USED FOR MANUFACTURING, TENDERING OR FOR ANY OTHER PURPOSE WITHOUT THEIR WRITTEN PERMISSION.

TOLERANCES
X. = ±1mm
X.X = ±0.50mm
X.XX = ±0.10mm
X.XXX = ±0.01mm
ANGLES = ±5°
UNLESS STATED

MATERIAL:
SEE ABOVE

FINISH: SEE ABOVE

S/AREA: mm²

TITLE: SMT RFI SHIELD CLIP IN TAPE AND REEL

DRAWING NUMBER: S0961-46R

SHT 2 OF 2

Mouser Electronics

Authorized Distributor

Click to View Pricing, Inventory, Delivery & Lifecycle Information:

[Harwin:](#)

[S0961-46R](#)