

SWITCH WILL OPERATE BY MOVING ACTUATOR  
 IN ANY DIRECTION EXCEPT PULL

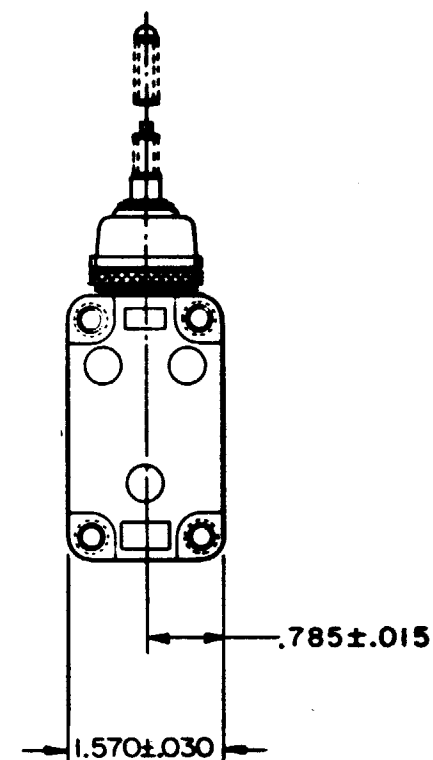
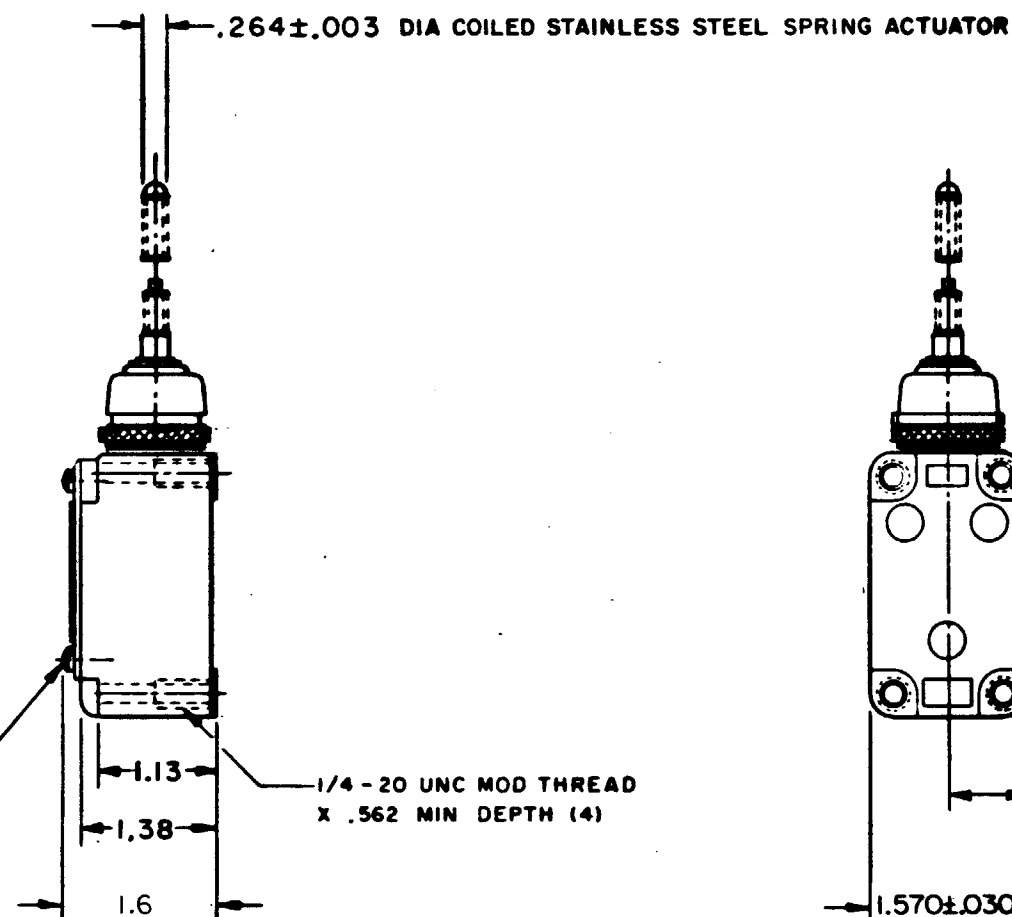
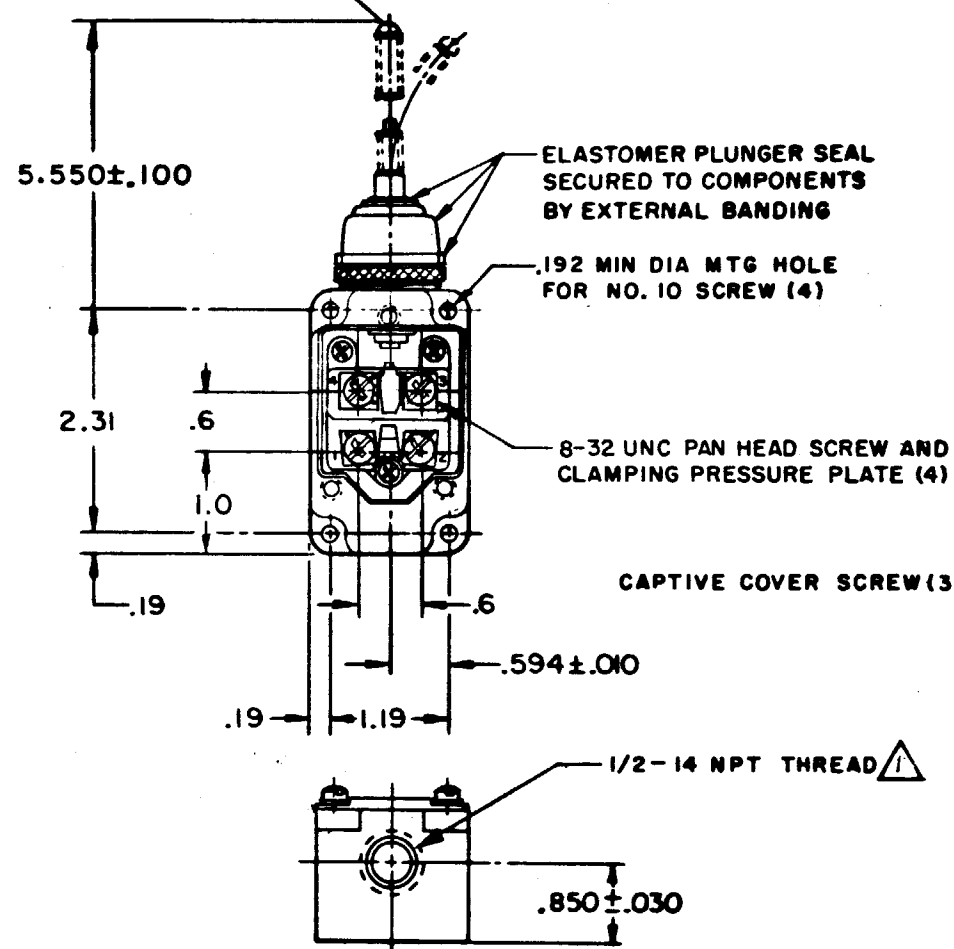

NOTE-

▲ SEAL TO BE FURNISHED BY USER

THIS DRAWING COVERS A PROPRIETARY ITEM AND IS THE PROPERTY OF MICRO SWITCH, A DIVISION OF MINNEAPOLIS-HONEYWELL REGULATOR CO. THIS DRAWING IS NOT TO BE COPIED OR USED WITHOUT THE APPROVAL OF MICRO SWITCH.

CHARACTERISTICS	ELECTRICAL DATA	SCALE 1/2 TO 1
OPERATING FORCE --- 5 OZ MAX	CONTACT ARRANGEMENT (SEE CIRCUIT DIAGRAM)	DO NOT SCALE PRINT
FORCE AT 2.0 --- 10 OZ MAX	10A-120, 240 OR 480 VAC 1/3 HP-120 VAC; 3/4 HP-240 VAC 0.8A-115 VDC; 0.4A-230 VDC; 0.1A-550 VDC PILOT DUTY 600 VAC MAX	UNLESS OTHERWISE NOTED DIMENSIONS ARE IN INCHES TOLERANCES ARE: ONE PLACE (.01) ±.030 TWO PLACE (.001) ±.015 THREE PLACE (.000) ±.008 ANGLES ±
SWITCH-BASIC REPLACEMENT --- 2MN1		WEIGHT

8LS152

PAGE 1 OF 1

M

DRAWING NUMBER

ISSUE 12

REVISIONS

A C094494  
 JAF  
 22 MAR 99

REPLACES

SR12327

RELEASE NO.

CHECK

CHECK

26 MAY 66

CHECK

26 MAY 66

FORMTEK

PO-80379-003

DRAWN

M B F