



Pneumatic Cylinders

*Short stroke cylinders
Series C05 and C05S*

Catalogue 9127003942GB-ul



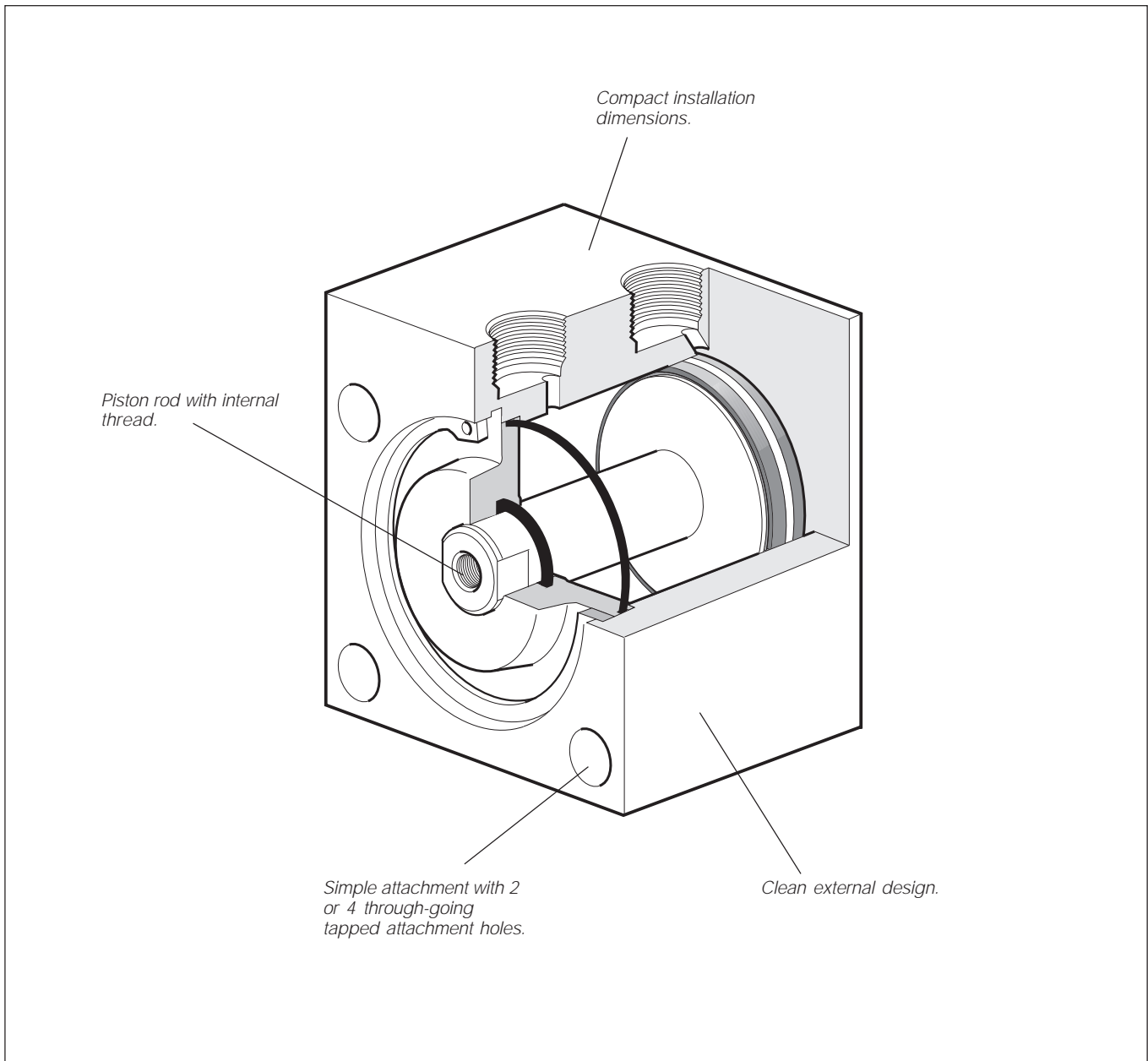

Cylinders, type C05 and C05S

Compact short stroke cylinders available in single as well as double acting versions. Ideally suited for clamping and locking operations the range includes bores from 12 to 63 mm, providing thrust forces of up to 3000 N.

The design has been optimized to include the following features:

Installation

The compact design with mounting holes through the cylinder body makes the unit easy to install in confined spaces.

Clean design

The main body is machined from one piece thus providing an easy to clean unit. Fitted with stainless steel piston rod as standard for corrosion resistance.

Maintenance free

The units are pre-lubricated for use also without additional lubrication, reducing maintenance costs as well as providing an improved working environment.

Main data

Cylinder	Cylinder		Piston rod		Theor. piston force		Air consumption ¹⁾ l	Spring force N	Stroke mm	Weight Kg
	bore mm	area cm ²	diam mm	area cm ²	at 6 bar in N plus stroke	minus stroke				
C05S-8-4-4	8	0.5	4	0.13	28	-	0,0045	2	4	0.016
C05S-12-5-4	12	1.1	5	0.20	65	-	0,0099	3	4	0.023
C05S-20-10-4	20	3.1	10	0.79	184	-	0,0151	6	4	0.067
C05S-32-12-5	32	8.0	12	1.13	463	-	0,0653	17	5	0.192
C05S-50-16-10	50	19.6	16	2.01	1145	-	0,1695	35	10	0.416
C05S-63-16-10	63	31.1	16	2.01	1825	-	0,2602	45	10	0.663
C05-12-5-10	12	1.1	5	0.20	68	56	0,0186	-	10	0.045
C05-20-10-10	20	3.1	10	0.79	190	143	0,0505	-	10	0.125
C05-32-12-10	32	8.0	12	1.13	480	415	0 1236	-	10	0.320
C05-32-12-25	32	8.0	12	1.13	480	415	0 1236	-	25	0.400
C05-50-16-25	50	19.6	16	2.01	1180	1060	0,3167	-	25	0.675
C05-63-16-25	63	31.1	16	2.01	1870	1750	0,4982	-	25	0.800

1) Consumption of free air per 10 mm stroke for a double stroke at 600 kPa (6 bar).

Data

Working pressure Max 10 bar
Working temperature -20 °C to +70 °C

Prelubricated, further lubrication is not normally necessary.
If additional lubrication is introduced it has to be continued.

Material specifications

Cylinder housing Black anodized aluminium
Front end cover Brass
Front end cover,
single action Ø50-63 Black anodized aluminium
Piston rod bearing
single action Ø50-63 Brass/PTFE/lead
Piston, Ø8-32 mm Stainless steel
Piston, Ø50-63 mm Aluminium
Piston rod Stainless steel
Seals Nitrile, NBR
Circlip Steel spring
Return spring Surface treated steel spring

**Important**

Before attempting any external or internal work on the cylinder or any connected components, make sure the cylinder is vented and disconnect the air supply in order to ensure isolation of the air supply.

Note

Air quality is essential for maximum cylinder service life (see ISO 8573).

Note

All technical data in this catalogue is typical data only.

Order key

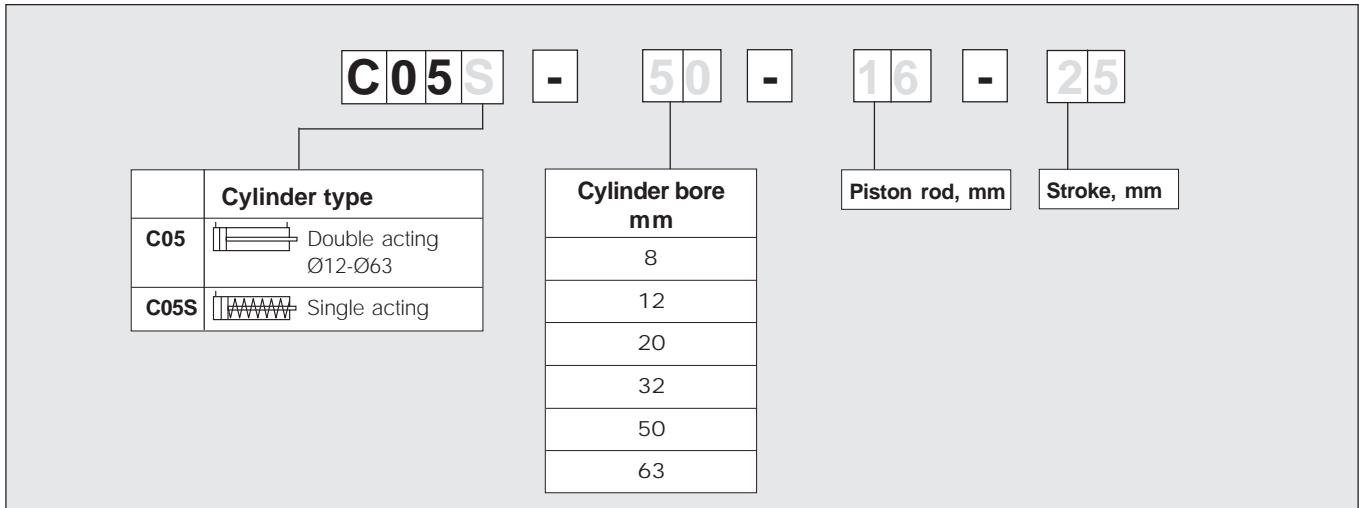

Main data for C05 and C05S cylinders

Symbol	Cyl. dia. mm	Piston rod mm	Spring force		Conn. thread	Stroke mm	Weight Kg	Designation
			Max N	Min N				
Double acting 	12	5/-			M5	10	0,01	C05-12-5-10
	20	10/M5			M5	10	0,25	C05-20-10-10
	32	12/M6			G1/8	10	0,30	C05-32-12-10
					G1/8	25	0,79	C05-32-12-25
	50	16/M8			G1/4	25	0,65	C05-50-16-25
63	16/M8			G1/4	25	1,07	C05-63-16-25	
Single acting 	8	4/-	3	2	M5	4	0,02	C05S-8-4-4
	12	5/-	7	3	M5	4	0,02	C05S-12-5-4
	20	10/M5	10	6	G1/8	4	0,16	C05S-20-10-4
	32	12/M6	25	19	G1/8	5	0,21	C05S-32-12-5
	50	16/M8	42	35	G1/4	10	0,36	C05S-50-16-10
	63	16/M8	58	45	G1/4	10	0,56	C05S-63-16-10

Indicated cylinder forces are theoretical and should be reduced according to the working conditions.

Dimensions, basic cylinder

Single acting

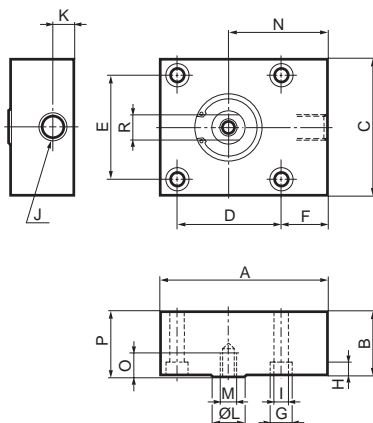

Type	A	B	C	D	E	F	G	H	I	J	K	KA	KB	L
C05S-8-4-4	20	16	18	0*	11	5,5	6	3,4	3,4	M5	5,0	-	-	4
C05S-12-5-4	25	16	20	0*	13	7,0	6	3,4	3,4	M5	6,0	-	-	5
C05S-20-10-4	40	20	32	0*	20	9,0	10	5,0	5,5	G1/8	9,5	-	-	10
C05S-32-12-5	55	26	45	0*	32	14,0	10	5,0	5,5	G1/8	9,5	-	-	12
C05S-50-16-10	80	30	65	50	50	22,5	11	6,5	6,5	G1/4	11,0	-	-	16
C05S-63-16-10	90	35	80	62	62	19,0	15	9,0	9,0	G1/4	11,0	-	-	16

Type	M	N	O	P	R
C05S-8-4-4	-	13,5	-	17	-
C05S-12-5-4	-	15,0	-	17	-
C05S-20-10-4	M5	24,0	8	21	-
C05S-32-12-5	M6	32,0	12	27	9
C05S-50-16-10	M8	47,5	12	31	14
C05S-63-16-10	M8	50,0	14	36	14

Double acting

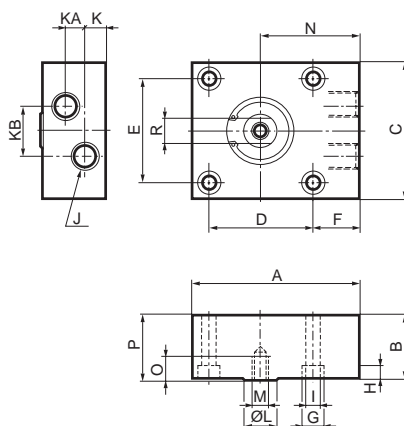

Type	A	B	C	D	E	F	G	H	I	J	K	KA	KB	L
C05-12-5-10	25	27	20	0*	13	7,0	6	3,4	3,4	M5	6,0	13,0	3	5
C05-20-10-10	40	30	32	0*	20	9,0	10	5,0	5,5	M5	6,0	16,0	6	10
C05-32-12-10	55	36	45	0*	32	14,0	10	5,0	5,5	G1/8	9,5	16,5	14	12
C05-32-12-25	55	51	45	0*	32	14,0	10	5,0	5,5	G1/8	9,5	31,5	0**	12
C05-50-16-25	80	50	65	50	50	22,5	11	6,5	6,5	G1/4	11,0	28,0	0**	16
C05-63-16-25	90	55	80	62	62	19,0	15	9,0	9,0	G1/4	11,0	33,0	0**	16

Type	M	N	O	p	R
C05-12-5-10	-	16,0	-	28	-
C05-20-10-10	M5	24,0	8	31	-
C05-32-12-10	M6	32,0	12	37	9
C05-32-12-25	M6	32,0	12	52	9
C05-50-16-25	M8	47,5	12	51	14
C05-63-16-25	M8	50,0	14	56	14

* Only two mounting holes (F).

** Connections in-line.