

Unit Camera DIY KIT

SKU:U109-X



Description

UNIT CAMERA DIY KIT is a powerful DIY ESP32 WiFi camera kit, which includes two lens modules: Wide-angle fisheye + regular view, both using OV2640 image sensor supporting up to 200w pixel output. DIY case design, You will get a DIY model for so much fun right out of the box! Compact size, high resolution and focus capabilities they are, It's excellent for a variety of IoT image capture applications.

- High flexibility.
 - Lens focus support
 - GROVE expansion interface with programmable RGB lights
- Plug-and-play.
 - Self image transfer firmware with UART/WIFI image transfer support
 - Integrated image parameter API interface (white balance, exposure, gain, size, etc.)
 - PC-based debugging tools
 - Support UIFlow graphical programming platform for one-click invocation and cloud transmission
 - Works with Arduino, ESP32-IDF and other mainstream development platforms

Product Features

- Plug-and-play
- Rich image processing API interface
- Fascinating DIY structure model cover
- Built-in ESP32 MCU

Includes

- 1x Unit CAM core board
- 1x OV2640 camera (FOV:66.5°)
- 1x OV2640 camera (FOV:160°)

- 1x OV2640 Camera (FOV:160°)
- 1x Model Housing Kit
- 1x Camera Back Clip (LEGO compatible)
- 1x HY2.0-4P Cable

Applications

- Remote Monitoring
- Camera Timer

Specifications

Specifications	Parameters
ESP32-WROOM-32E	240MHz Dual Core, 600DMIPS, 520KB SRAM, Wi-Fi, Dual Mode Bluetooth
Flash	4MB
Wide Angle Fisheye Lens	Focal length 1.0±5%mm
	Aperture 2.2±5%
	Lens type 1/4inch
	Field of view 160°
	Pixels 200w
	Reverberation -135%
Conventional view lens	Sensitive chip OV2640
	Focal length 4.8±5%mm
	Aperture 2.4±5%
	Lens type 1/4inch
	Field of view 65°
	Pixels 200w
Firmware default communication method	Reverberation <1%
	Sensor chip OV2640
	UART: 115200bps 8N1
Camera firmware default output image	QVGA@28fps, VGA@13fps, support for adjustments (UXGA, SXGA, XGA, and other larger image sizes output)
Sensor output format support	YUV(422/420)/YCbCr422,8-bit compressed data,RGB565/555,8-/10-bit raw RGB data
Net Weight	21.8g
Gross Weight	49.1g
Model board	11 * 66 * 181mm

Specifications

Parameters

Fisheye camera assembly size	40 * 24 * 17.2mm
Assembly size for normal camera	40 * 24 * 11m
Package Size	25 * 73 * 220mm

Flash Burning Download

The Unit CAM does not include a program download circuit. If you need to download an updated program for the ESP32, you can do so by connecting an external USB-TTL downloader.

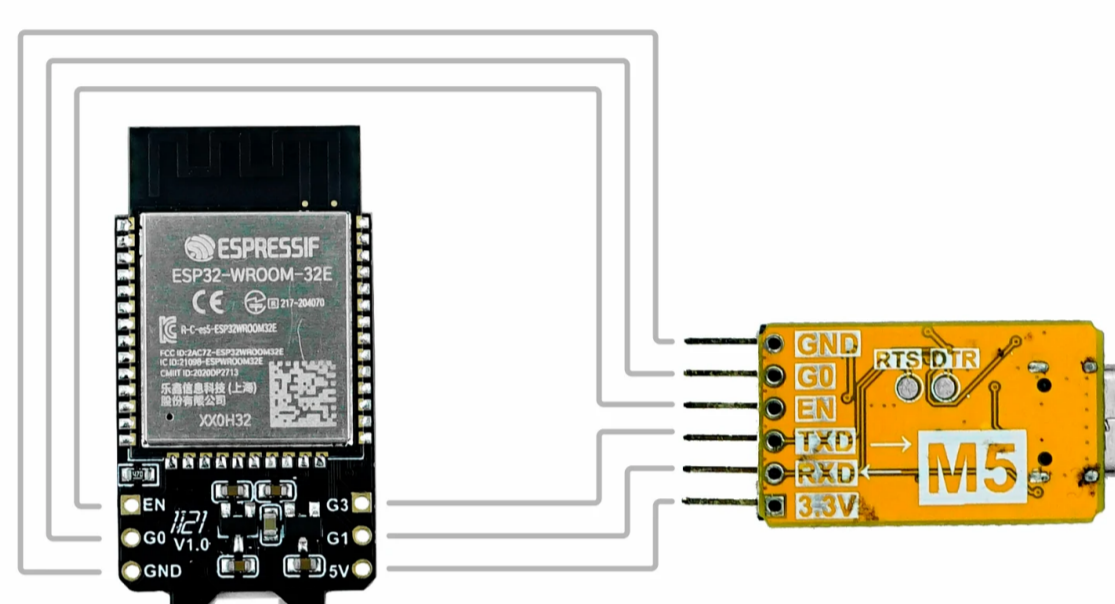

Pin Mapping

OV2640 Interface

<i>interface</i>	<i>camera pins</i>	<i>unit CAM</i>
SCCB Clock	SIOC	IO23
SCCB Data	SIOD	IO25
System Clock	XCLK	IO27
Vertical Sync	VSYNC	IO22
Horizontal Reference	HREF	IO26
Pixel Clock	PCLK	IO21
Pixel Data Bit 0	D0	IO32
Pixel Data Bit 1	D1	IO35
Pixel Data Bit 2	D2	IO34
Pixel Data Bit 3	D3	IO5
Pixel Data Bit 4	D4	IO39
Pixel Data Bit 5	D5	IO18
Pixel Data Bit 6	D6	IO36

<i>interface</i> Pixel Data Bit 7	<i>camera pins</i> D7	<i>unit CAM</i> IO19
Camera Reset	RESET	IO15
Camera Power Down	PWDN	-1
Power Supply 3.3V	3V3	3V3
Ground	GND	GND

HY2.0-4P Interface.

<i>HY2.0-4P</i>	<i>Unit CAM</i>
RX	IO16
TX	IO17
5V	5V
GND	GND

LED (Blue)

<i>LED</i>	<i>Unit CAM</i>
D1	IO4

schematic

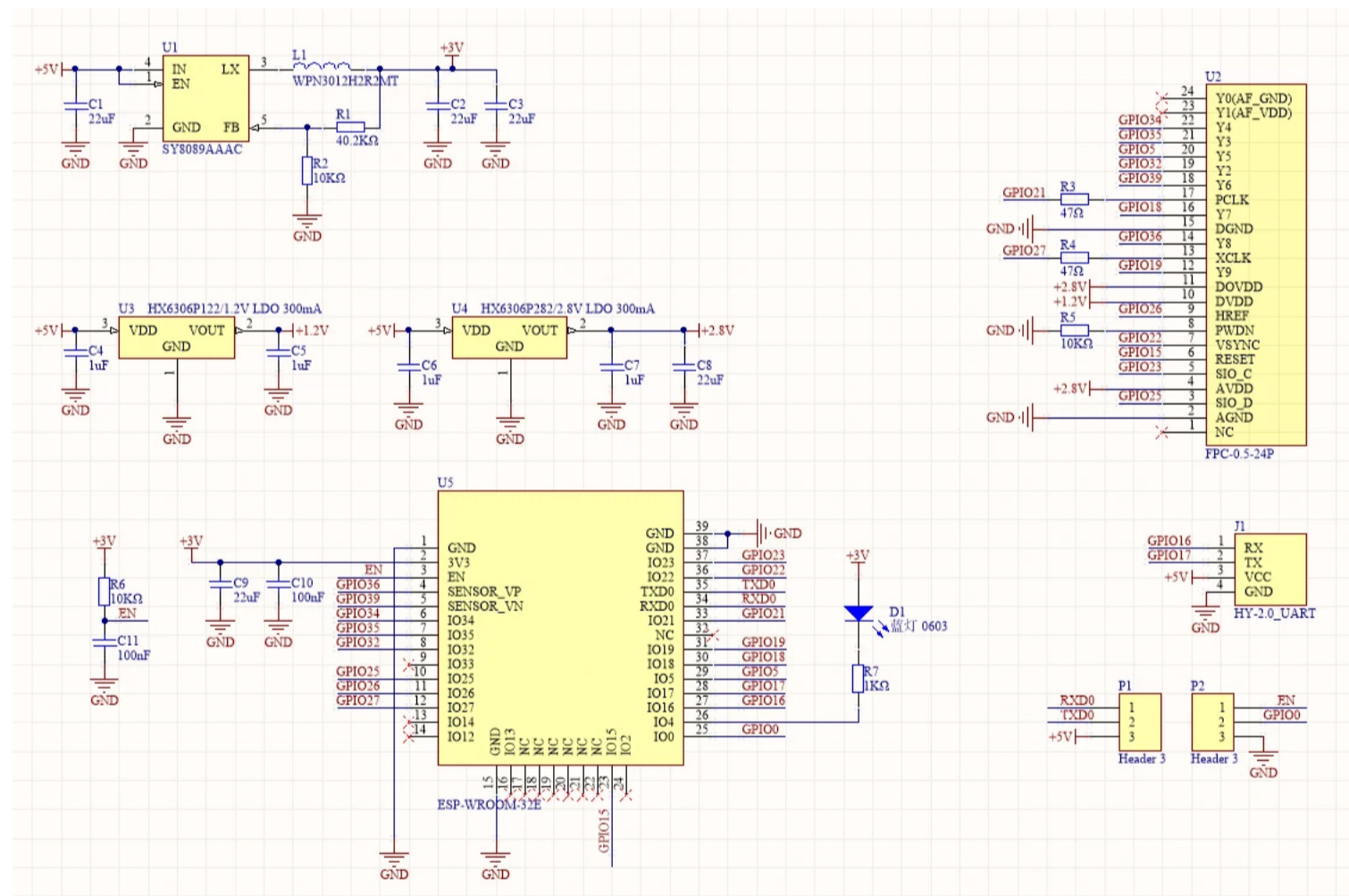

Related Links

- [Datasheet](#)
 - [esp32-wroom-32e](#)
 - [OV2640](#)

Case program

Arduino

- [Camera UART to Core](#)

UIFlow

The default firmware of UnitCAM supports both UART and WiFi modes. WiFi mode supports taking pictures at regular intervals and uploading them to M5 cloud automatically, and returning the picture calling interface (URL). UART mode supports users to use other master devices to get picture frames and modify picture parameters through UART communication.

Unit CAM UIFlow Block Instructions

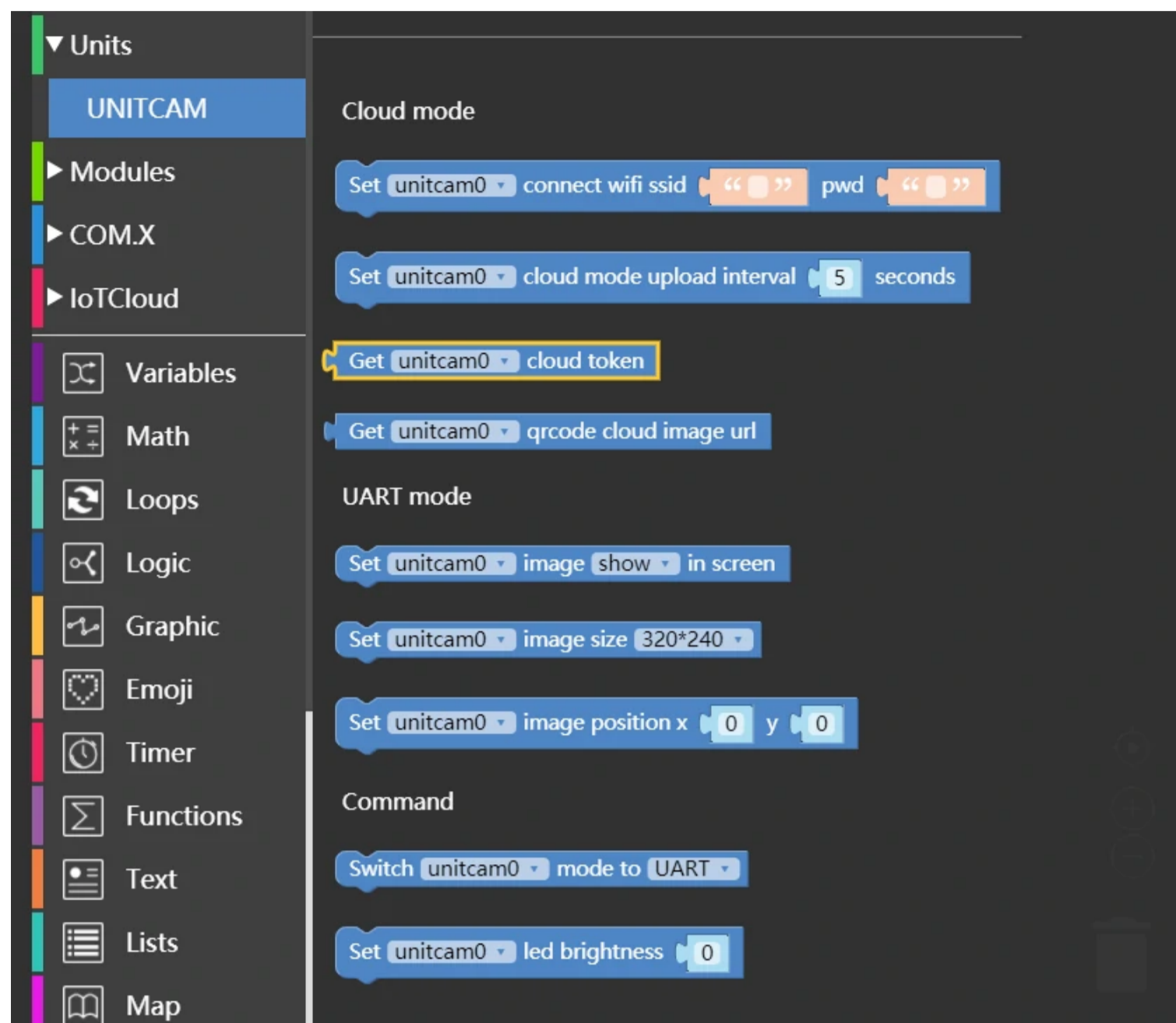

Unit CAM UIFlow Use Case

Press A to enable WiFi connection mode, connect to the designated WiFi, the camera takes pictures at 5s intervals and upload them to the M5 cloud, and press B to obtain the camera Token, and use the cloud image URL generated by the Token to create a QR code.

Press C to enable UART connection mode, configure the picture size to be 320*240, and start the picture display thread to continuously refresh the picture to the screen.

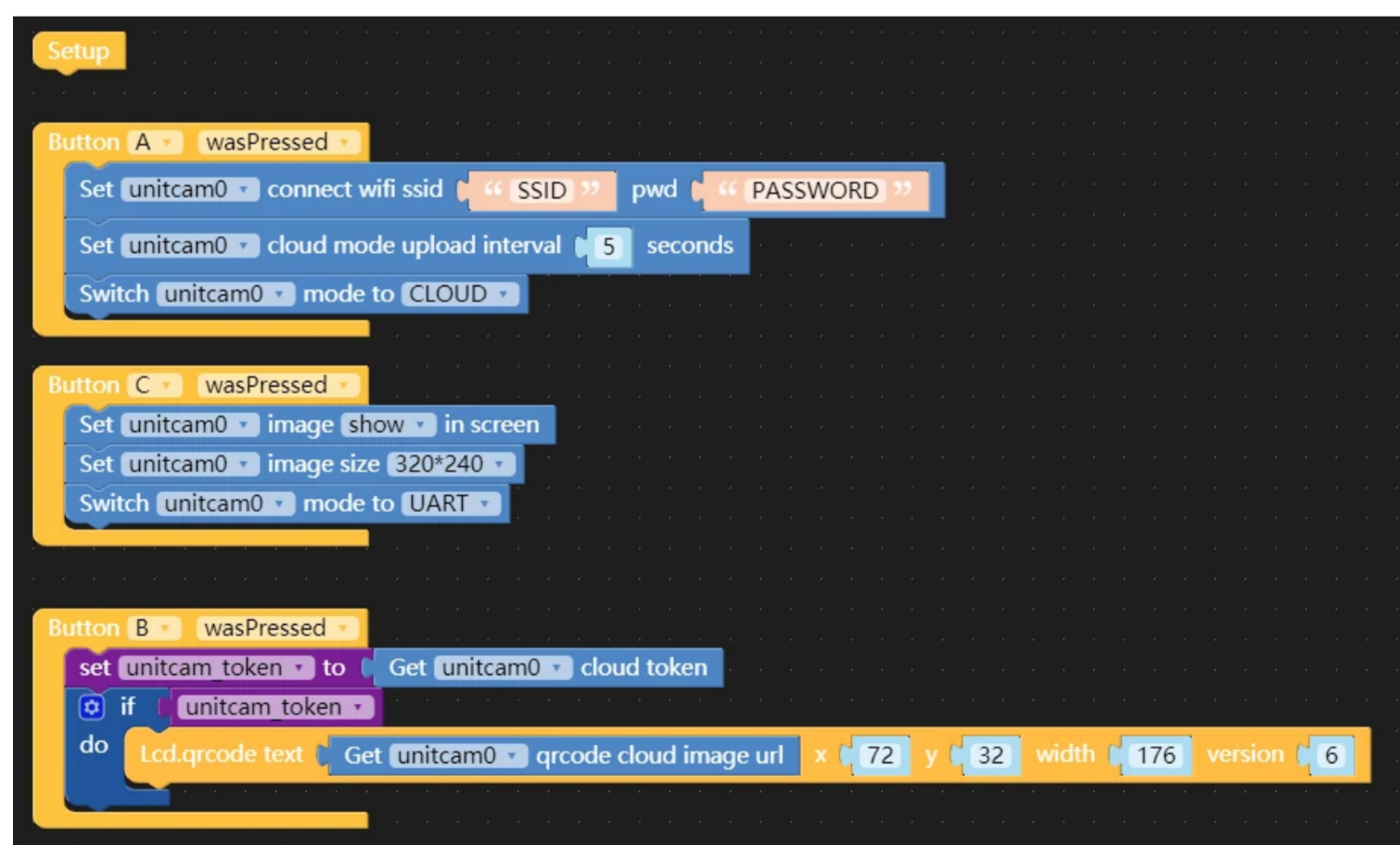

Unit CAM UIFlow Block function description:

- Cloud Mode Functions:

#Configure the camera to connect to the specified WiFi

Set-unitcam-connect-wifi-ssid

#Configure the camera image upload cloud interval

Set-unitcam-cloud-mode-upload-interval

#Get camera Token

Get-unitcam-cloud-token

```
Get-unitcam-cloud-token
```

```
#Get the URL of the camera cloud image
```

```
Get-unitcam-cloud-image-url
```

```
- UART Mode Functions:
```

```
#In UART mode, start the screen display image thread, the default display coordinates are 0,0
```

```
Set-unitcam-image-show-in-screen
```

```
#Set the camera to return the image size
```

```
Set-unitcam-image-size
```

```
#Set the image display position
```

```
Set-unitcam-image-position-x-y
```

```
- Command:
```

```
#Switch UART/CLOUD mode
```

```
Switch-unitcam-mode-to-UART/CLOUD
```

```
#Set the brightness of the onboard LED of the camera
```

```
Set-unitcam, led-brightness
```

Micropython API

```
import unit
```

```
#Create unitcam instance
```

```
unitcam0 = unit.get(unit.UNITCAM, unit.PORTB)
```

```
#UART Mode: unitcam0.UART_MODE
```

```
#WiFi mode: unitcam0.CLOUD_MODE
```

```
unitcam0.set_mode(unitcam0.UART_MODE)
```

```
#WiFi mode, configure the camera to connect to the specified WiFi
```

```
unitcam0.set_wifi('', '')
```

```
#WiFi mode, configure the camera image upload cloud interval
```

```
unitcam0.set_upload_time(5)
```

```
#Get camera token
```

```
unitcam_token = unitcam0.get_token()
```

```
#Stitching a fixed domain name field to get the URL of the camera cloud image
```

```
unicam_image_url = 'camera.m5stack.com/timer-cam/image?tok=' + unitcam0.get_token()
```

```
#UART mode, start the screen display image thread, the default display coordinates are 0,0
```

```
unitcam0.set_show(True)
```

```
#Set the camera to return the image size
```

```
#unitcam0.SIZE_800_600
```

```
#unitcam0.SIZE_640_480
```

```
#unitcam0.SIZE_320_240
```

```
#unitcam0.SIZE_240_240
```

```
#unitcam0.SIZE_160_120
```

```
unitcam0.set_image_size(unitcam0.SIZE_320_240)
```

```
#Set Unit CAM onboard LED brightness value: 0~100  
unitcam0.set_led_brightness(0)
```

| Video

- Unpacking and manual assembly