

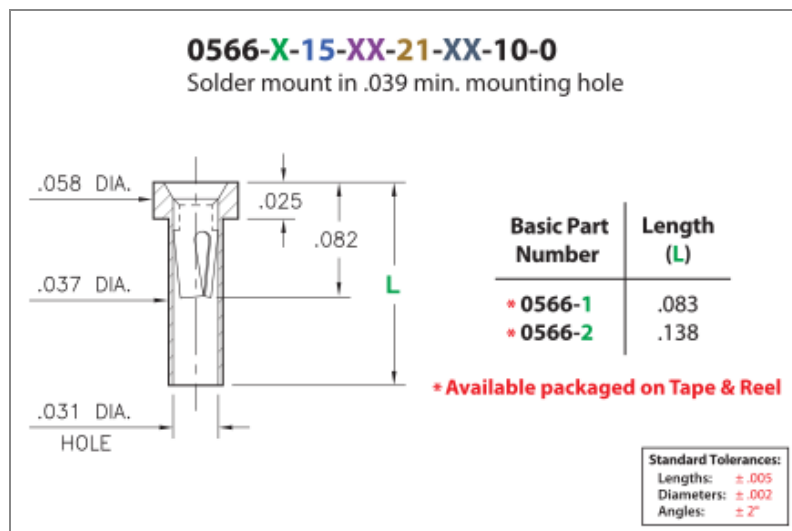

PRODUCT NUMBER: 0566-1-15-15-21-27-10-0

www.mill-max.com  
DATA SHEET



## 0566-1-15-15-21-27-10-0 SPECIFICATIONS

General Info	
<b>Description<sup>1</sup>:</b>	Receptacle With No Tail
<b>Mounting Feature<sup>2</sup>:</b>	Solder Mount
<b>Mounting Hole:</b>	.039" (0,991mm)
<b>Pin Diameter Range:</b>	.015"-.022" (0,381-0,559mm)
<b>Packaging:</b>	Packaged in Bulk
<b>RoHS<sup>3</sup>:</b>	Yes
<b>Product Lifecycle<sup>4</sup>:</b>	Active

Materials	
<b>Shell Material<sup>5</sup>:</b>	Brass Alloy
<b>Shell Plating<sup>6</sup>:</b>	10 μ" Gold over Nickel
<b>Contact Plating<sup>7</sup>:</b>	30 μ" Gold over Nickel

Technical Specs	
<b>Durability<sup>8</sup>:</b>	1,000 Cycles Minimum
<b>Operating Temperature Range<sup>9</sup>:</b>	-55/+125° C
<b>Current Rating<sup>10</sup>:</b>	3A @ 10°C Temperature Rise
<b>Contact Resistance<sup>11</sup>:</b>	10 mΩ Max
<b>Shock<sup>12</sup>:</b>	No Elect. Discontinuity > 1μs @ 50g
<b>Vibration<sup>13</sup>:</b>	No Elect. Discontinuity > 1μs @ 10-2000HZ, 20 G

## NOTES:

1. Standard Tolerances:  
Lengths  $\pm .005"$  (0,13)  
Diameters:  $\pm .002"$  (0,051)  
Angles:  $\pm 2^\circ$
2. For through-hole solder mounting of this part, the suggestion is to make the finished hole size, at its minimum,  $.004"$  larger than the diameter being soldered into the mounting hole.
3. Mill-Max products labeled with the RoHS symbol are compliant with all three ROHS Directives. All of our products previously described as RoHS (2002/95/EC) and RoHS-2 (2011/65/EC) are also compliant with RoHS-3 (2015/863/EU).
4. Part is Active and in Production, No Scheduled Obsolescence
5. Brass Alloy 360 per ASTM B 16, or 385 per ASTM B455
6. GOLD per ASTM B 488, Type 1 (99.7% min. gold), Code C (130-200 HK {Knoop hardness}); NICKEL per ASTM B 689, Type 2 (Bright),
7. GOLD per ASTM B 488, Type 1 (99.7% min. gold), Code C (130-200 HK {Knoop hardness}), NICKEL per ASTM B 689, Type 2 (Bright)
8. Receptacles are capable of 1,000 Minimum insertion/extraction cycles for a broad range of applications. Mating pin size, shape and finish, along with application specific variables, will affect the life of a receptacle contact.
9. Per IEC 60512-11-(4,-9,-10,-12)
10. Per IEC 60512-5-1, Current Carrying Capacity (evaluated at  $10^\circ\text{C}$  Temp. Rise)
11. Per EIA-364-23C, Low Level Contact Resistance
12. Per IEC 60512-6-3: Test 6c: Shock
13. Per IEC 60512-6-4: Test 6d: Vibration (sinusoidal)

## ADDITIONAL PARTS, PACKAGING, & ASSEMBLY INFO

### 0566-1-15-XX-21-XX-10-0

Solder mount in  $.039$  min. mounting hole  
Also available on 16mm wide X 8mm pitch carrier tape:  
3,000 parts per 13" reel  
Order as: 0566-1-57-XX-21-XX-10-0

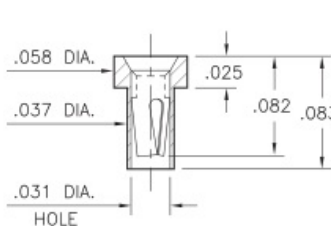

Standard Tolerances:  
Lengths:  $\pm .005$   
Diameters:  $\pm .002$   
Angles:  $\pm 2^\circ$

### 0566-2-15-XX-21-XX-10-0

Solder mount in  $.039$  min. mounting hole  
Also available on 16mm wide X 8mm pitch carrier tape:  
2,100 parts per 13" reel  
Order as: 0566-2-57-XX-21-XX-10-0

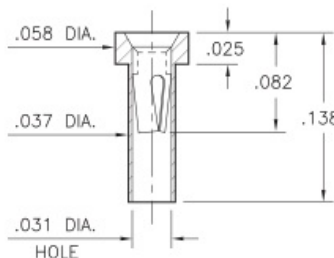

Standard Tolerances:  
Lengths:  $\pm .005$   
Diameters:  $\pm .002$   
Angles:  $\pm 2^\circ$

## CONTACT:

# #21 CONTACT

FOR .015"-.022" DIAMETER PINS ( $\delta = .004$ )

3-FINGER (BeCu), GROUP A

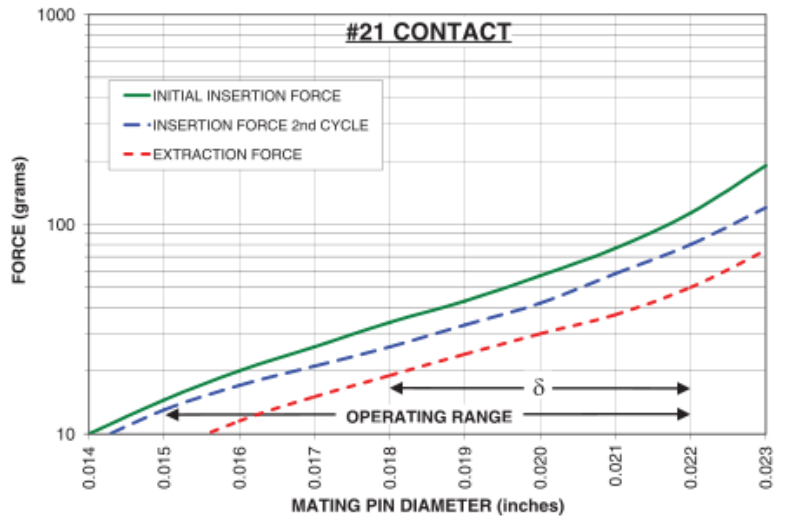
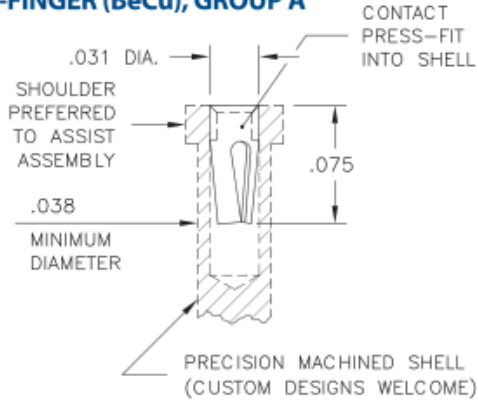

The insertion / extraction force characteristics above were derived using a 30 microinch gold-plated contact and polished steel gauge pins having a bullet-shaped tip. The curves represent typical average values; they are best used to compare the differences between similar size contacts and to guide you in selecting one that is suitable for your application. Your results may vary, so for your specification, we encourage you to obtain complimentary samples for your evaluation.

Material	Beryllium Copper	Current Rating (amps)	3.00
Fingers	3	Compliance	0.004
Length	.080" (2,032mm)	Contact Group	A

## ADDITIONAL NOTES AND SPECIFICATIONS

In the interest of improved design, quality and performance, Mill-Max reserves the right to make changes in its specifications without prior notice. Specifications and tolerances are provided wherever possible. The tolerance on dimensions of critical to function features is typically held tighter than the stated standard tolerances, such as press-fits, holes and lengths affecting the coplanarity of SMT products. Due to the wide variety of interconnects Mill-Max offers, the specific tolerances vary from product to product. If you need information regarding the tolerance of a particular part, please contact Technical Services.

## RELATED LINKS AND DOCUMENTS

Engineering Notebook: ( <https://www.mill-max.com/engineering-notebooks/pin-receptacles-the-backbone-of-your-interconnect-system> )

Environmental Compliance: ( <https://www.mill-max.com/rohs> )