

HAMMOND MANUFACTURING. AUTO TRANSFORMER
176E
 INPUT 115V 50/60Hz 750VA
 OUTPUT 230V 3.26A
 DATE _____ MADE IN CANADA
 UL LISTED (POWER SUPPLY) 89PN

DIMENSIONS:	
A	3.841" ±0.063
B	6.436" ±0.125
C	4.680" ±0.063
D	3.000" ±0.063
E	5.312" ±0.063
G	0.203" x 0.375" ±0.015

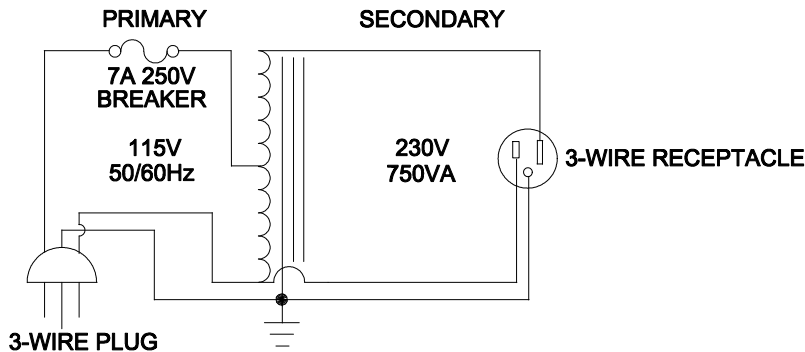
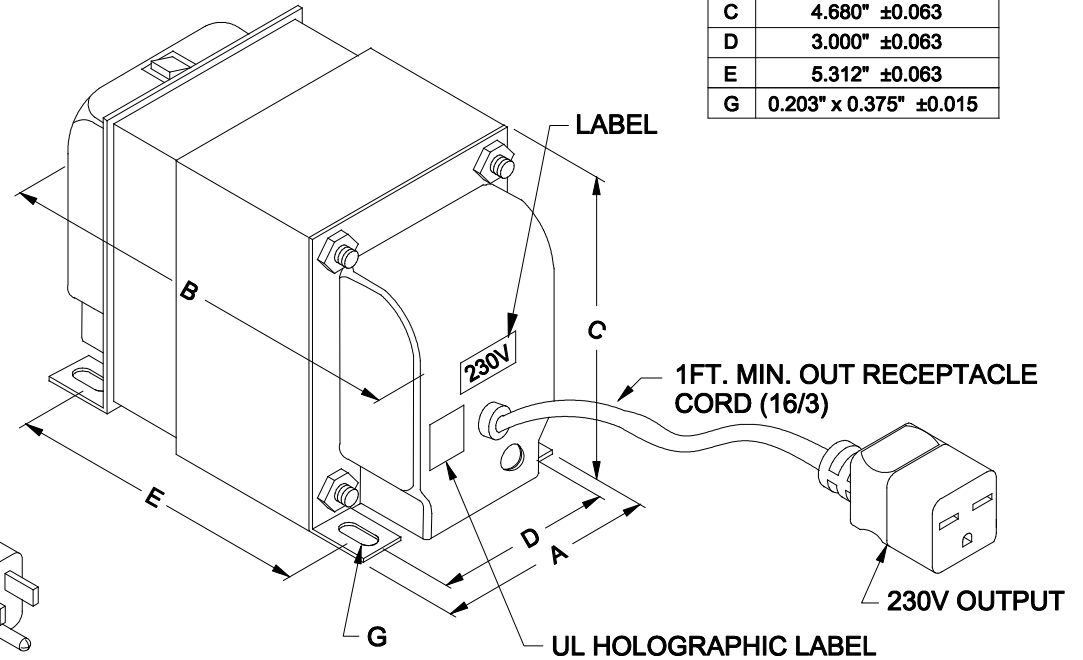
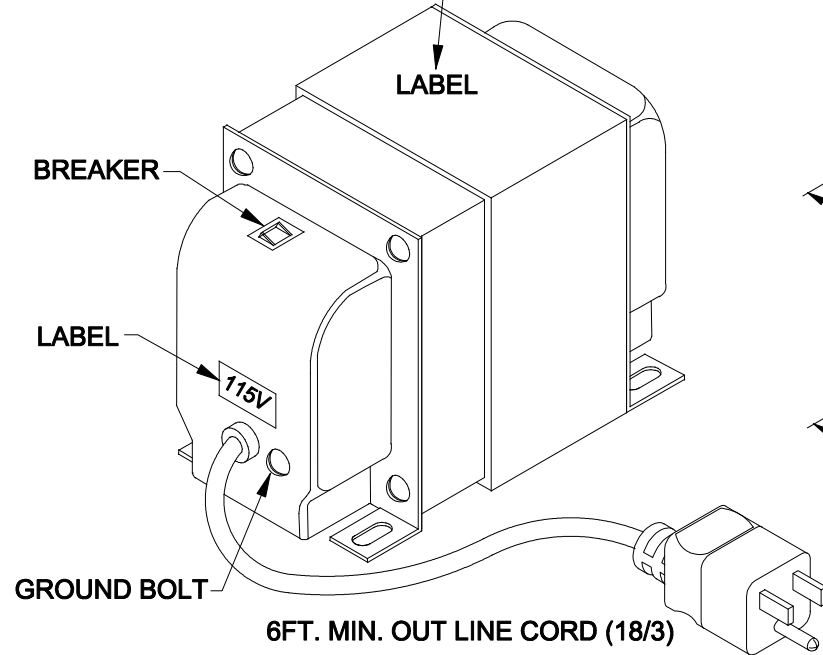

ELECTRICAL DATA:		
TESTS	CONDITIONS	ACCEPTANCE CRITERIA
Iex	@ 115V, 60Hz, TO CORD PLUG	500mA Max.
Sec. N.L.V	@ 115V, 60Hz, TO CORD PLUG RECEPTACLE PLUG =	233.8V ±2%
DCR	@ 20°C, TO CORD PLUG =	0.310 Ω ±20%
	@ 20°C, RECEPTACLE PLUG =	0.610 Ω ±20%
HIPOT	PRIMARY - CORE	2000V, 60Hz, 1 SEC

REV.#	REVISION	DATE
0	RELEASED.	C.I. 11/24/21

HAMMOND MANUFACTURING ELECTRONIC DIVISION
 52 RANKIN PLACE, WATERLOO, ONTARIO, N2J 3Z5
 PH # (519) 886-6181 FAX # (519) 886-9540

DWG. BY: C. ILIE CHK'D BY: _____
 DATE: 11/24/21 APP'D. BY: _____
 DIMENSIONS: IN(X) MM()

TITLE: AUTO-TRANSFORMER STEP UP - PLUG IN
 DWG. NO. 176E