

PRODUCT NUMBER: 0914-0-15-20-77-14-11-0

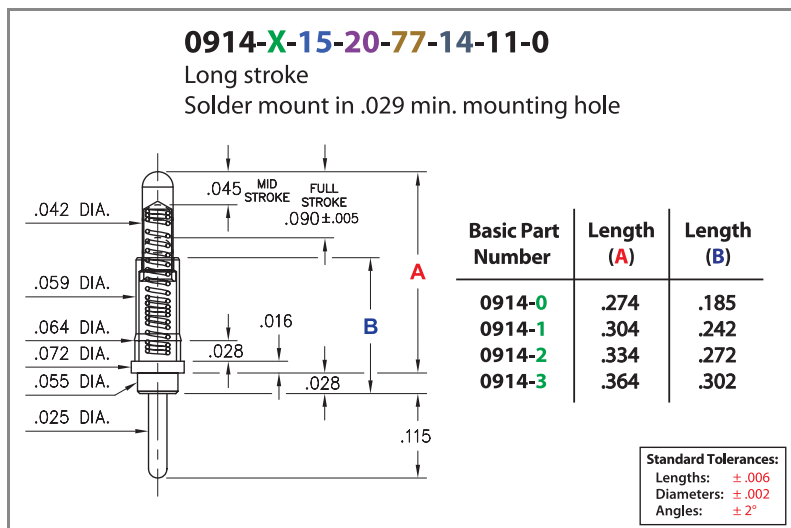

DESCRIPTION

Spring-Loaded Pin with a Standard Tail

Durability:

Up to 1,000,000 Cycles @ Mid-Stroke

Current Rating:

2A continuous, 3A peak @ 10°C Temperature Rise

Contact Resistance:

20 mΩ Max

Operating Temperature Range:

-55/+125° C

Vibration:

No Elect. Discontinuity > 1μs @ 10-2000HZ, 20 G

Shock:

No Elect. Discontinuity > 1μs @ 50g

Mounting Feature:

Through-Hole Solder Mount

Tail Type: Solder tail

Mounting Hole: .029" (0,737mm)

Tail Diameter: .025" (0,635mm)

Packaging: 15 - Packaged in Bulk

Shell Plating	Spring Plating	ROHS
----------------------	-----------------------	-------------

20 μ" Gold over Nickel

10 μ" Gold over Nickel



SPRING:			
Material	Beryllium Copper	Grams Force	60
Max Stroke	0.09		

CONTACT MATERIAL:

BERYLLIUM COPPER ALLOY 172 (UNS C17200) per ASTM B 194

Properties of BERYLLIUM COPPER:

- Chemical composition: Cu 98.1%, Be 1.9%
- Hardness: 36-43 Rockwell C

- Density: .298 lbs/in³
- Electrical Conductivity: 22% IACS*
- Resistance: 10 mΩ Max
- Operating Temperature: -55°C/+125°C
- Melting point: 980°C/865°C (liquidus/solidus)
- Stress Relaxation†: 96% of stress remains after 1,000 hours @ 100 °C; 70% of stress remains after 1,000 hours @ 200 °C

*International Annealed Copper Standard, i.e. as a % of pure copper.

†Since BeCu loses its spring properties over time at high temperatures; it is rated for continuous use up to 150°C. For applications up to 300°C, Mill-Max offers other materials. [Contact Tech Support](#) for more info.

STANDARD TOLERANCES ON PCB TERMINAL PINS & RECEPTACLES

Diameters +/- .002"

Lengths +/- .005"

Angles +/- 2°

STANDARD TOLERANCES ON SPRING-LOADED PINS

Diameters +/- .002"

Lengths +/- .006"

Angles +/- 2°

ADDITIONAL NOTES & SPECIFICATIONS

In the interest of improved design, quality and performance, Mill-Max reserves the right to make changes in its specifications without prior notice. Specifications and tolerances are provided wherever possible. The tolerance on dimensions of critical to function features is typically held tighter than the stated standard tolerances, such as press-fits, holes and lengths affecting the coplanarity of SMT products. Due to the wide variety of interconnects Mill-Max offers, the specific tolerances vary from product to product. If you need information regarding the tolerance of a particular part, please contact Technical Services.

 © 2021 Mill-Max Mfg. Corp.

190 Pine Hollow Rd, Oyster Bay, NY 11771, USA

Phone: 516.922.6000