

This document is the property of Amphenol Corporation and is delivered on the express condition that it is not to be disclosed, reproduced or used, in whole or in part, for manufacture or sale by anyone other than Amphenol Corporation without its prior consent, and that no right is granted to disclose or to use any information in this document.

The marking on this product doesn't contain environmental hazardous materials per Material Specification SS-00259 for Sony GP compliant or per directive 2011/65/EU for RoHS compliant.

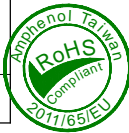

ORIGINAL



REVISIONS				
SYM	ECN No.	DESCRIPTION	DATE	APPROVED
A		RELEASE TO PRODUCTION	03/12/2010	Roger Tsai
B	NE-11149	ADDED PIN DEFINITION	10/28/2011	Roger Tsai
C	NE-16208	MODIFIED DIM/ADDED OPENING & PACKAGE OPTION	09/07/2016	Roger Tsai
D	NE-18003	ADDED DIMENSION 9.40(C4), 0.40(E4),0.50(E4)	01/04/2018	Roger Tsai

TERMINATION ASSIGNMENT

CONTACT NO.	SIGNAL NAME	WIRING COLOR
P1	VBUS	RED
P2	D-	WHITE
P3	D+	GREEN
P4	ID	NOT CONNECTED
P5	GND	BLACK

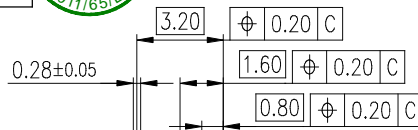

PART NO. GMSB052 X 1 X 2EU

CONTACT FINISH
 0: GOLD FLASH
 1: 15 μ" GOLD
 2: 30 μ" GOLD
 PACKAGE OPTION
 3: TAPE & REEL
 5: TRAY

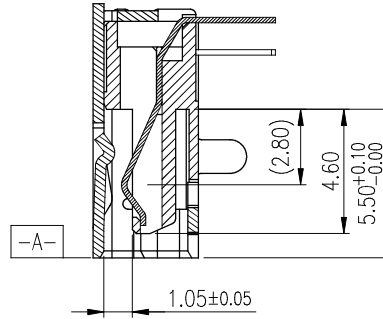
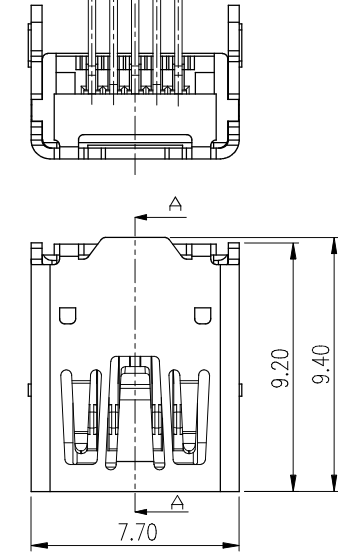
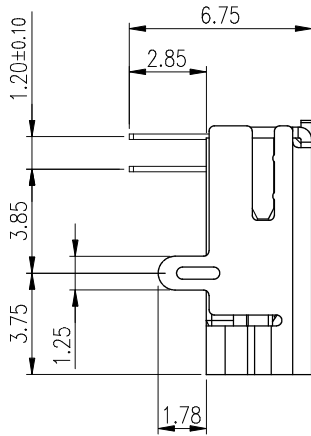

SECTION A-A

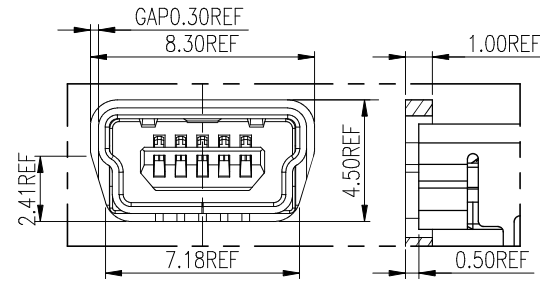
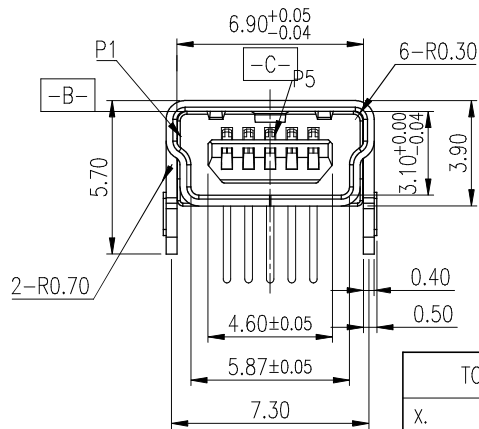

RECOMMENDED OPENING

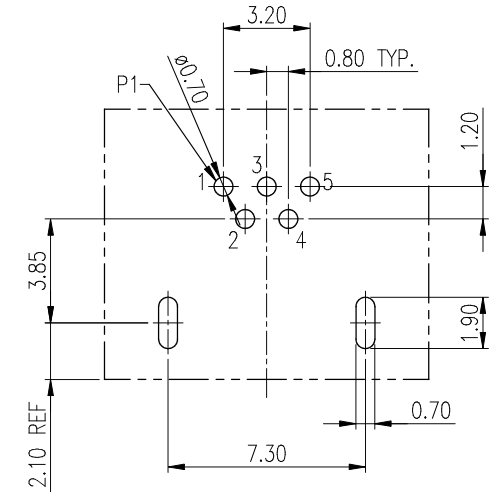

RECOMMEND PC BOARD LAYOUT
 TOLERANCE: ±0.05 mm

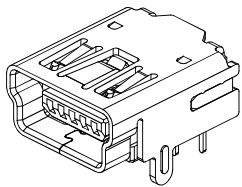

TOLERANCE	DRAWN	APPROVALS	DATE	TITLE
X. ±0.30	DESIGNED	Karen Su	01/04/2018	MINI USB B TYPE RECEPTACLE CONNECTOR DIP, R/A TYPE
X.X ±0.20	CHECKED	Aqua Chou	01/04/2018	
X.XXX ±0.10	APPROVED	Roger Tsai	01/04/2018	
ANGULAR ±1°	DWG TYPE	CUST DWG	PROJECT CODE OTHER	
UNLESS OTHERWISE SPECIFIED				

UNIT	SIZE	PART No.	REV.
mm	A3	GMSB052X1X2EU	D
SCALE	SHEET	DWG No.	
NA	1 OF 2	GMSB052X1X2EU	

This document is the property of Amphenol Corporation and is delivered on the express condition that it is not to be disclosed, reproduced or used, in whole or in part, for manufacture or sale by anyone other than Amphenol Corporation without its prior consent, and that no right is granted to disclose or to use any information in this document.

The marking on this product doesn't contain environmental hazardous materials per Material Specification SS-00259 for Sony GP compliant or per directive 2011/65/EU for RoHS compliant.



ORIGINAL



REVISIONS				
SYM	ECN No.	DESCRIPTION	DATE	APPROVED
A		RELEASE TO PRODUCTION	03/12/2010	Roger Tsai
B	NE-11149	ADDED PIN DEFINITION	10/28/2011	Roger Tsai
C	NE-16208	MODIFIED DIM/ADDED OPENING & PACKAGE OPTION	09/07/2016	Roger Tsai
D	NE-18003	ADDED DIMENSION 9.40(C4), 0.40(E4),0.50(E4)	01/04/2018	Roger Tsai

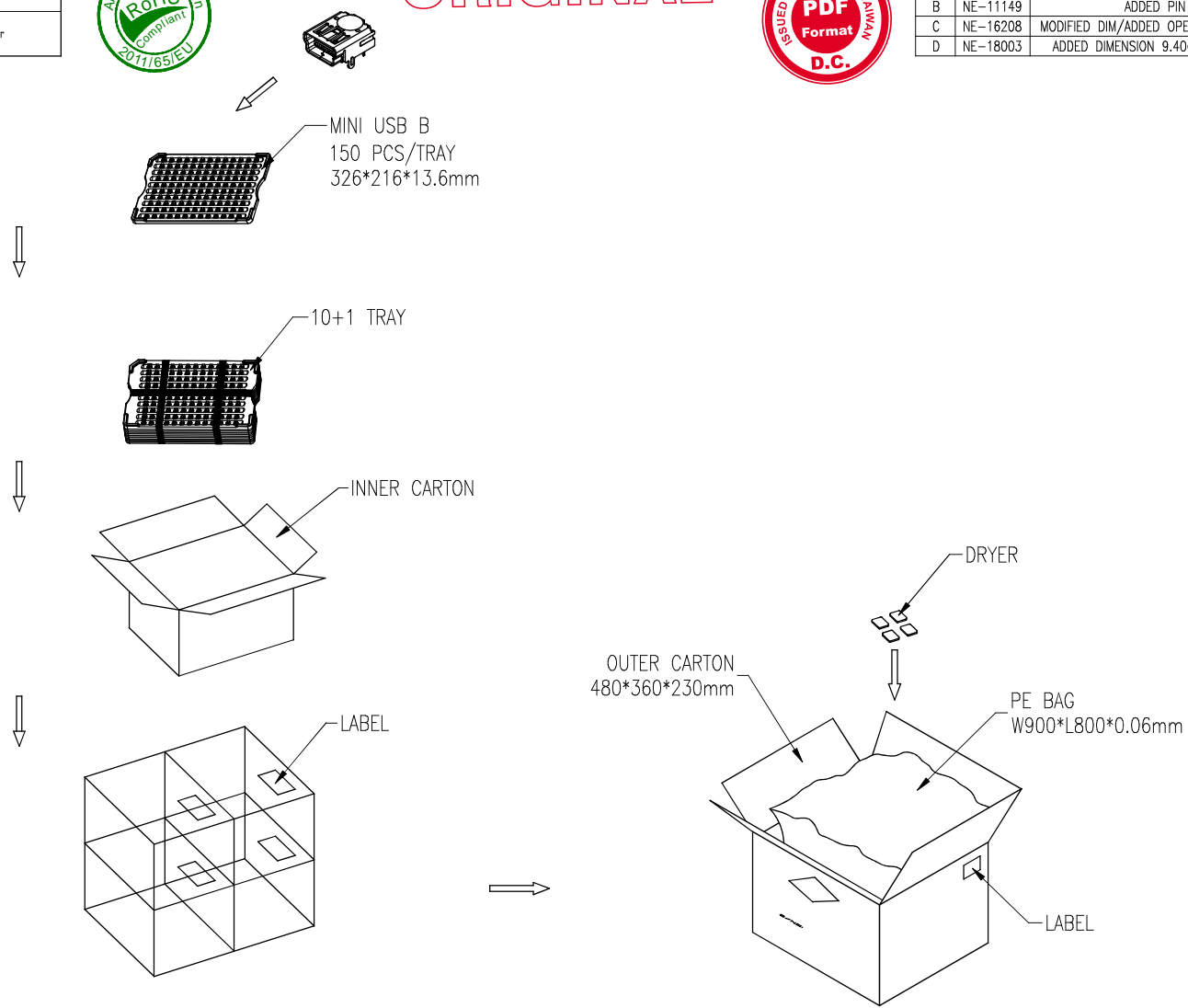

PACKAGING BY TARY	8.5	3.73	150	10+1	4	6000	GMSB052X152EU
	G/W KG	N/W KG	PCS/ TARY	TARYS/ INNER CARTON	INNER CARTON/ OUT CARTON	QUANTITY (PCS)	PART NUMBER

TOLERANCE	DRAWN	APPROVALS	DATE	TITLE		PART No.	
X. X.X ±0.30 X.XX ±0.20 X.XXX ±0.10	DESIGNED	Karen Su	01/04/2018	MINI USB B TYPE RECEPTACLE CONNECTOR DIP, R/A TYPE		GMSB052X1X2EU	
	CHECKED	Roger Tsai	01/04/2018			Amphenol® Amphenol Corporation Amphenol Taiwan Corporation	
ANGULAR ±1°	APPROVED	Roger Tsai	01/04/2018			REV. D	
UNLESS OTHERWISE SPECIFIED	DWG TYPE	CUST DWG	PROJECT CODE	OTHER	UNIT	SCALE	SHEET
					mm	NA	2 OF 2
					SIZE		DWG No.
					A3		GMSB052X1X2EU

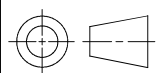

This document is the property of Amphenol Corporation and is delivered on the express condition that it is not to be disclosed, reproduced or used, in whole or in part, for manufacture or sale by anyone other than Amphenol Corporation without its prior consent, and that no right is granted to disclose or to use any information in this document.

The marking on this product doesn't contain environmental hazardous materials per Material Specification 55-00259 for Sony GP compliant or per directive 2002/95/EC for RoHS compliant.



ORIGINAL



REVISIONS				
SYM	ECN No.	DESCRIPTION	DATE	APPROVED
A		RELEASE TO PRODUCTION	03/12/2010	Roger Tsai

10	PROTECTIVE TAPE	10	PCS		
9	LABEL	1	PCS		
8	LABEL	15	PCS		
7	DRYER	4	BAG		
6	PE BAG	1	PCS	L850*W750mm	
5	OUTER CARTON	1	PCS		
4	INNER CARTON	5	PCS		
3	REEL	10	SET	ø330*100mm,W=24mm	
2	COVER TAPE	550	10	PCS	W=21.5mm,9.5M
1	CARRIER TAPE				W=24mm,T=0.35mm,9.5M/REEL
NO	PACKING NAME	PCS/T	T/BOX	UNIT	NOTE
		PACKING QTY			

NOTES:

- PACKING STYLE 550 PCS/REEL
2 REEL/INNER CARTON
5,500 PCS/OUTER CARTON
- MATERIAL CARRIER TAPE:PS BLACK
COVER TAPE:PET FILM
REEL:PLASTIC
- PEEL STRENGTH OF COVER TAPE:20-80g(PEEL SPEED 300mm/MINUTE).

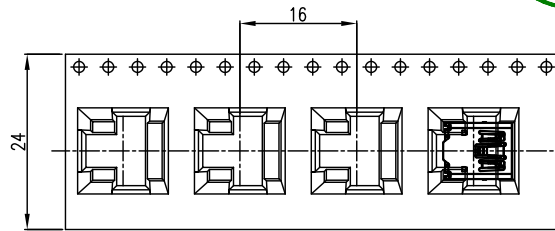

Unreeling direction

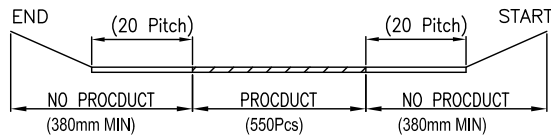
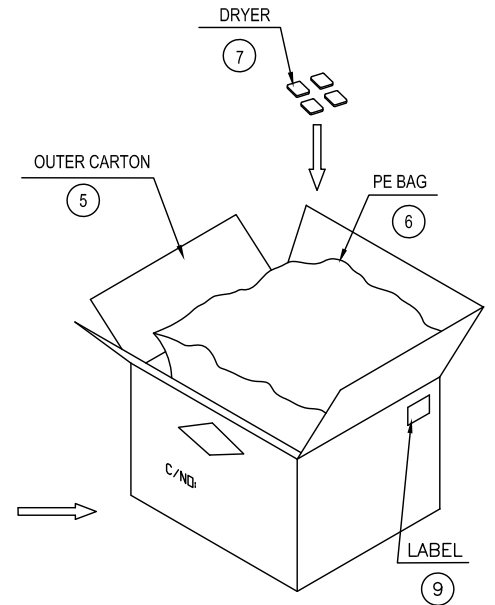
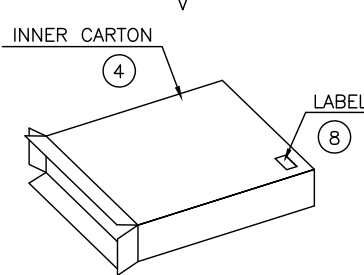
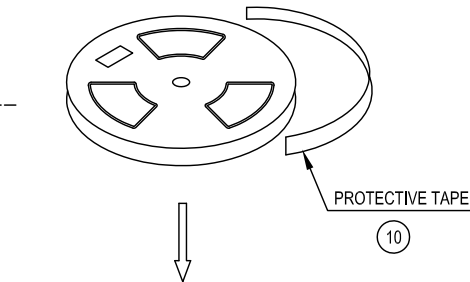
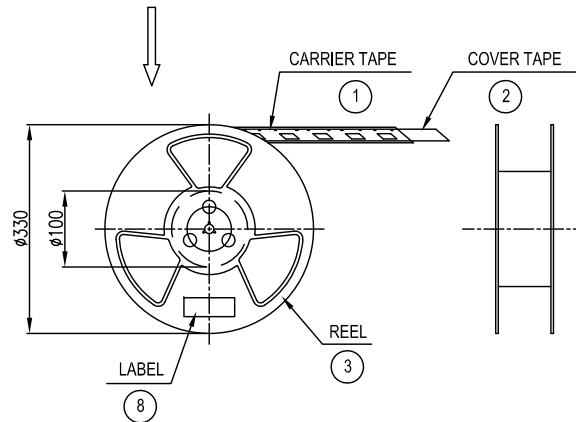

Unreeling direction

TOLERANCE		APPROVALS		DATE	TITLE		Amphenol® Amphenol Corporation Amphenol Taiwan Corporation							
X.		DRAWN	Roger Tsai	03/12/2010	PACKAGING SPECIFICATION FOR MINI USB B TYPE RECEPTACLE CONNECTOR R/A, DIP TYPE		UNIT	mm	SIZE	A3	PART No.	PKS-GMSB052X132EU		
X.X	±0.30	CHECKED	Chenny Yeh	03/12/2010			SCALE	NA	SHEET	1 OF 1	DWG No.	PKS-GMSB052X132EU	REV.	A
X.XX	±0.20	APPROVED	Roger Tsai	03/12/2010			DWG TYPE		CUST DWG		PROJECT CODE		OTHER	
X.XXX	±0.10	ANGULAR		±1°	UNLESS OTHERWISE SPECIFIED									