

# 14PIN

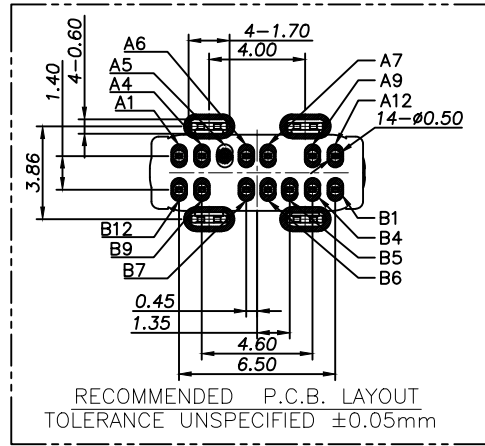

- NOTE:
- MATERIAL SPECIFICATION:
    - HOUSING: HIGH TEMPERATURE RESISTANT PLASTIC, UL94 V-0.
    - CONTACTS: COPPER ALLOY
    - MID PLATE: STAINLESS STEEL
    - SHELL: STAINLESS STEEL
  - MECHANICAL PERFORMANCE,
    - INSERTION FORCE: 5~20N.
    - REMOVAL FORCE: 8~20N.
    - DURABILITY: 10000 CYCLES.
  - ELECTRICAL PERFORMANCE,
    - CURRENT RATING: 3.0/5.0A  
VOLTAGE RATING: 20V
    - LLCR:
      - VBUS & GND PINS AND OTHER PINS: 40mΩ/PIN MAX.
      - SHIELD: 50mΩ/MAX.
      - LLCR MAX. CHANGE OF ALL PINS: 10mΩ.
    - INSULATION RESISTANCE: 100MΩ MIN
    - DIELECTRIC WITHSTAND VOLTAGE, AC 100V FOR 1 MINUTE.
  - ENVIRONMENTAL PERFORMANCE:
    - OPERATING TEMPERATURE: -25°C~+85°C.
    - IR REFLOW:
      - THE PEAK TEMPERATURE ON THE BOARD SHALL BE MAINTAINED FOR 10 SECONDS AT 260°C.

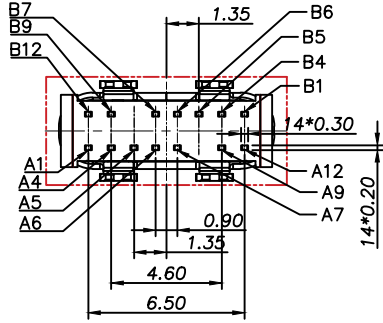
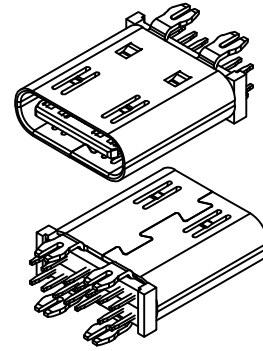
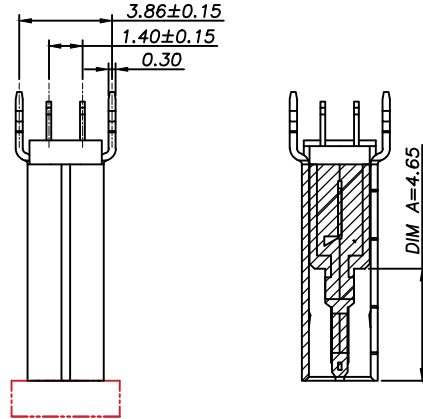
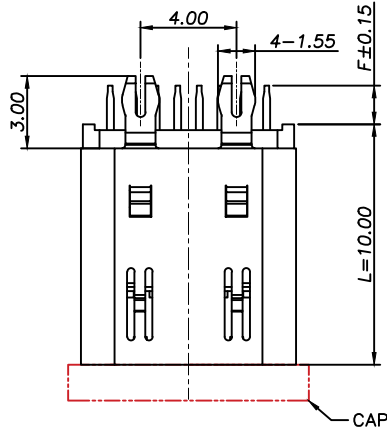

PIN NUMBER	SIGNAL NAME	PIN NUMBER	SIGNAL NAME
A1	GND	B12	GND
A4	VBUS	B9	VBUS
A5	CC1	B7	Dn2
A6	Dp1	B6	Dp2
A7	Dn1	B5	CC2
A9	VBUS	B4	VBUS
A12	GND	B1	GND

P/N	(F) 脚长	COLOER	额定电流
HC-TYPE C-14P-VS10.0D-3A-F1.6-02	1.60mm	黑色	3A
HC-TYPE C-14P-VS10.0D-3A-F1.6-0-02	1.60mm	0:橙色	3A
HC-TYPE C-14P-VS10.0D-3A-F1.6-Y-02	1.60mm	Y:黄色 (1000K)	3A
HC-TYPE C-14P-VS10.0D-3A-F1.6-G-02	1.60mm	G:绿色	3A
HC-TYPE C-14P-VS10.0D-3A-F1.6-W-02	1.60mm	W:白色	3A

**Ordering Information**

HC-TYPE C - 14P - \*\* \* - \*A - F\* - \* - 02

Pin	Type	Mount	Current	F=Foot	Colour
6P	TH=Top Mount (贴片)	1=单面	3A	W=White	蓝色(2950C)
6P	DS=DP+SMI (带插孔)	5=双孔	5A	W=White	蓝色(2950C)
8P	MM=Mid Mount (插孔)	5=双孔	5A	W=White	蓝色(2950C)
12P	CS=Center Height (插孔)	1=单脚	10A	L=Length	0=Green
16P	VS=Vertical SMT (直立式)	4=单孔	4=单脚	0=Green	0=Orange
24P	DP=DP (插孔)	4=单孔	4=单脚	P=Purple	P=Purple
	CP=Clip (插脚)	4=单脚		Y=Yellow	Y=Yellow
	FL=Flag (插脚)				

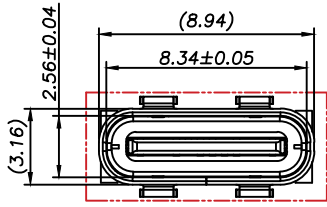

GENERAL TOLERANCE		制 图	
DRAWING		CHECK	
DIM	TOL	批 准	投 影
X.X	±0.30	比 例	材 料
X.XX	±0.20	SCALE	PROJECTION
X.XXX	±0.10	投 影	
Angle	±3.0°	材 料	

**深圳市华灿天禄电子有限公司**  
ShenzhenhuacantianluELECTRONICS CO.,LTD

产品名称 TITLE	TYPE CF 14P 直立式 带弹 L10.0mm 脚长1.6	版本 REV.	A
产品料号 PART NO.	HC-TYPE-C-14P-VS10.0D-XA-FX-X-02	单位 UNITS	mm
材料 MATERIAL		页次 SHEET	1/2

pcs/box	boxes/Carton	Pcs/Box
300	10	3000

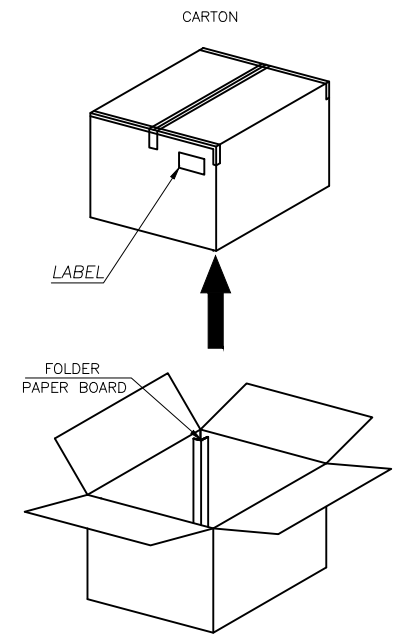
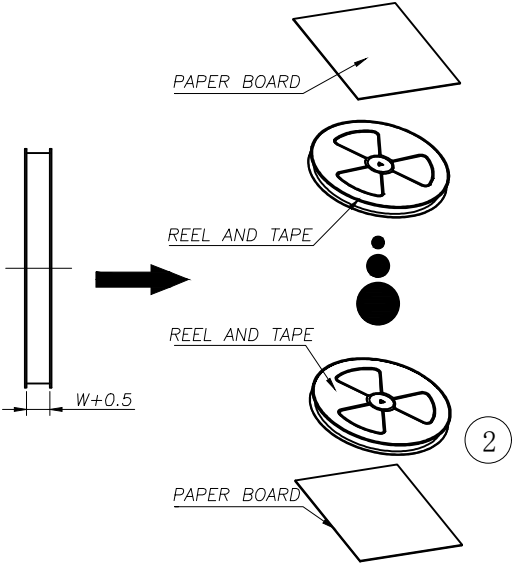
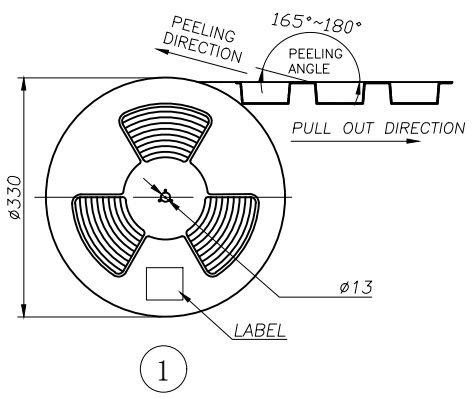
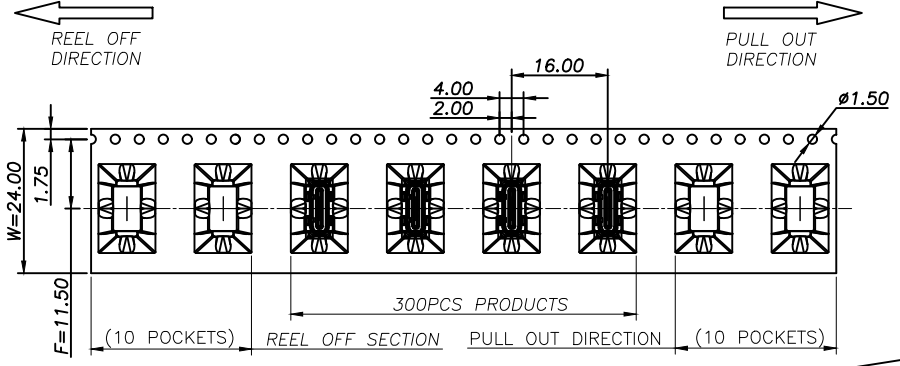

			GENREL TOLERANCE	制图 DRAWING	深圳市华灿天禄电子有限公司 ShenzhenhuacantianluELECTRONICS CO.,LTD			
			DIM TOL	审核 CHECK	产品名称 TITLE	TYPE CF 14P 直立式 带弹 L10.0mm 脚长1.6 -包装图	版本 REV.	A
			X.X ±0.30	批准 APPROVAL	产品料号 PART NO.	HC-TYPE C-14P-VS10.0D-XA-FX-02	单位 UNITS	mm
1	初版发行		X.XX ±0.20	比例 SCALE	材料 MATERIAL		页次 SHEET	2/2
序号 No.	变更内容 MODIFY CONTENT	日期 MODIFY DATE	X.XXX ±0.10	投影 Projection				
			Angle ±3.0°					