

14PIN

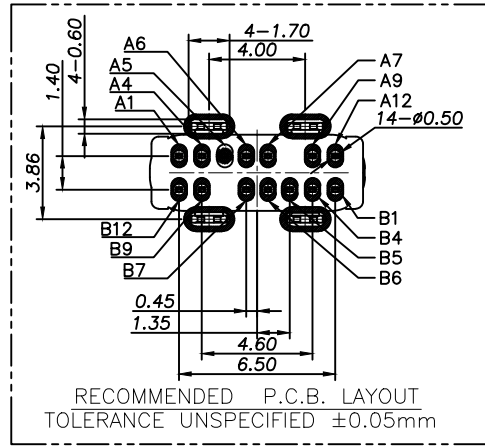

NOTE:

- MATERIAL SPECIFICATION:**
 - HOUSING: HIGH TEMPERATURE RESISTANT PLASTIC, UL94 V-0.
 - CONTACTS: COPPER ALLOY
 - MID PLATE: STAINLESS STEEL
 - SHELL: STAINLESS STEEL
- MECHANICAL PERFORMANCE,**
 - INSERTION FORCE: 5~20N.
 - REMOVAL FORCE: 8~20N.
 - DURABILITY: 10000 CYCLES.
- ELECTRICAL PERFORMANCE,**
 - CURRENT RATING: 3.0/5.0A
VOLTAGE RATING: 20V
 - LLCR: VBUS & GND PINS AND OTHER PINS: 40mΩ/PIN MAX.
SHIELD: 50mΩ/MAX.
LLCR MAX. CHANGE OF ALL PINS: 10mΩ.
 - INSULATION RESISTANCE: 100MΩ MIN
 - DIELECTRIC WITHSTAND VOLTAGE, AC 100V FOR 1 MINUTE.
- ENVIRONMENTAL PERFORMANCE:**
 - OPERATING TEMPERATURE: $-25^{\circ}\text{C} \sim +85^{\circ}\text{C}$.
 - IR REFLOW:
THE PEAK TEMPERATURE ON THE BOARD SHALL BE MAINTAINED FOR 10 SECONDS AT 260°C .

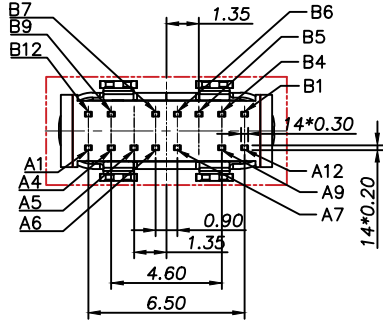
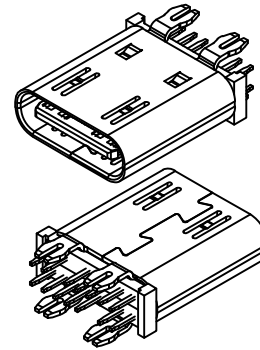
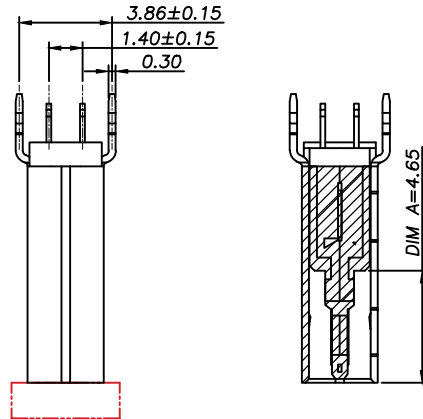
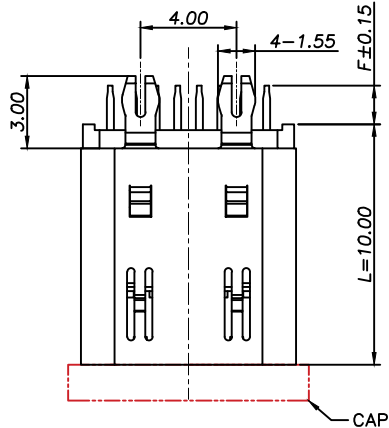

USB TYPE-C PIN ASSIGNMENTS

PIN NUMBER	SIGNAL NAME	PIN NUMBER	SIGNAL NAME
A1	GND	B12	GND
A4	VBUS	B9	VBUS
A5	CC1	B7	Dn2
A6	Dp1	B6	Dp2
A7	Dn1	B5	CC2
A9	VBUS	B4	VBUS
A12	GND	B1	GND

P/N	(F) 脚长	COLOER	额定电流
HC-TYPE C-14P-VS10.0D-3A-F1.2-02	1.20mm	黑色	3A
HC-TYPE C-14P-VS10.0D-3A-F1.2-B5-02	1.20mm	B5:蓝色(9990)	3A
HC-TYPE C-14P-VS10.0D-3A-F1.2-0-02	1.20mm	0:橙色	3A

Ordering Information

HC-TYPE C - 14P - ** * - *A - F* - * - 02

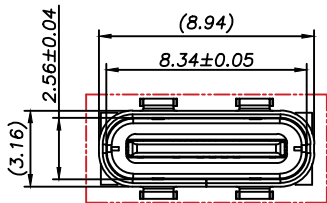
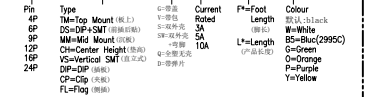

GENREL TOLERANCE		制图	审核
DRAWING		CHECK	批 准
X.X ±0.30		APPROVAL	比 例
X.XX ±0.20		SCALE	投 影
X.XXX ±0.10		Projection	材料
Angle ±3.0°			MATERIAL

深圳市华灿天禄电子有限公司
ShenzhenhuacantianluELECTRONICS CO.,LTD

产品名称	TYPE CF 14P 直立式 带弹	版本	A
TITLE	L10.0mm 脚长1.2	REV.	
产品料号	HC-TYPE C-14P-VS10.0D-XA-FX-02	单位	mm
PART NO.		UNITS	
材料		页次	1/2
MATERIAL		SHEET	

pcs/box	boxs/Carton	Pcs/Box
300	10	3000

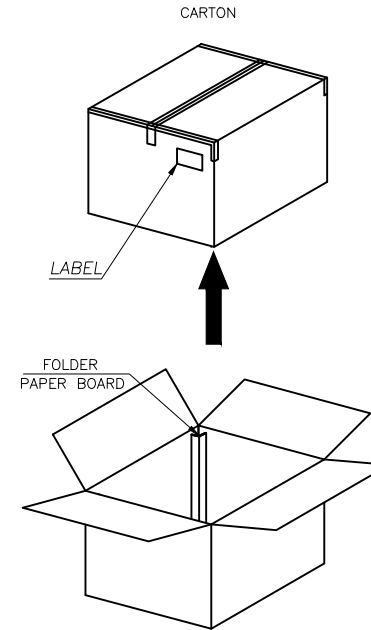
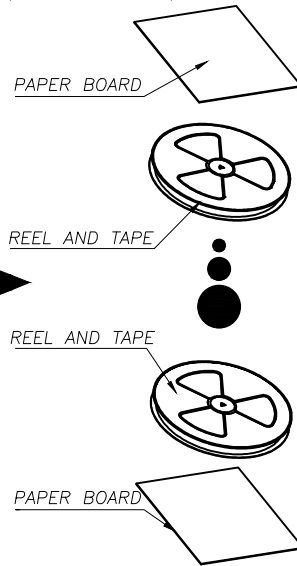
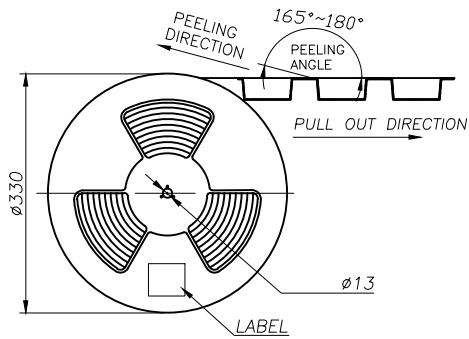
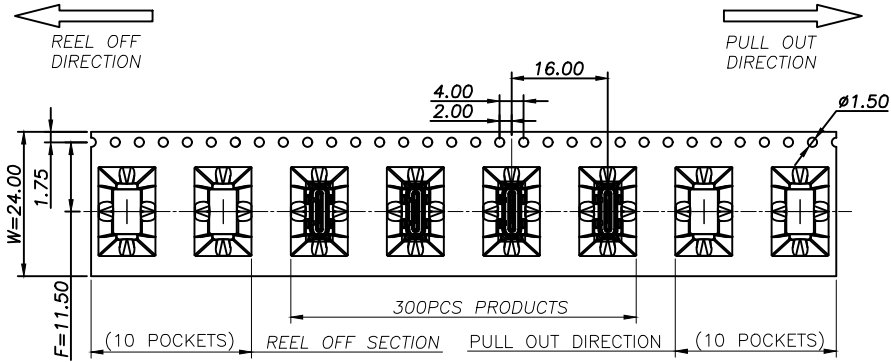

			GENREL TOLERANCE	制图 DRAWING	深圳市华灿天禄电子有限公司 ShenzhenhuaciantianluELECTRONICS CO.,LTD			
			DIM TOL	审核 CHECK				
			X.X ±0.30	批准 APPROVAL	产品名称 TITLE	TYPE CF 14P 直立式 带弹 L10.0mm 脚长1.2-包装图	版本 REV.	A
1 初版发行			X.XX ±0.20	比例 SCALE	产品料号 PART NO.	HC-TYPE C-14P-VS10.0D-XA-FX-02	单位 UNITS	mm
序号 No.	变更内容 MODIFY CONTENT	日期 MODIFY DATE	X.XXX ±0.10	投影 Projection	材料 MATERIAL		页次 SHEET	2/2
			Angle ±3.0°					