

THIS DRAWING IS SUPPLIED FOR INFORMATION ONLY. DESIGN FEATURES, SPECIFICATIONS AND PERFORMANCE DATA SHOWN HEREON ARE THE PROPERTY OF THE AMPHENOL CORPORATION. NO RIGHTS OF REPRODUCTION ARE IMPLIED. ALL DIMENSIONS ARE SUBJECT TO NORMAL MANUFACTURING VARIATIONS.

Customer Drawing

REVISIONS						
REV	ZONE	ECO	DESCRIPTION	DATE	BY	APPR
A	--	--	INITIAL RELEASE	12/01/14	RW	EC
B	--	--	料号更改从HCTF20XX改为HCTF120XX	01/28/15	RW	EC

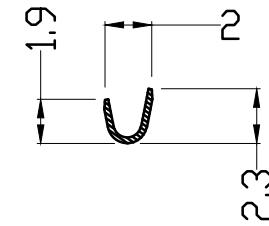
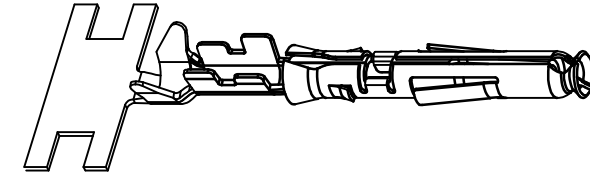
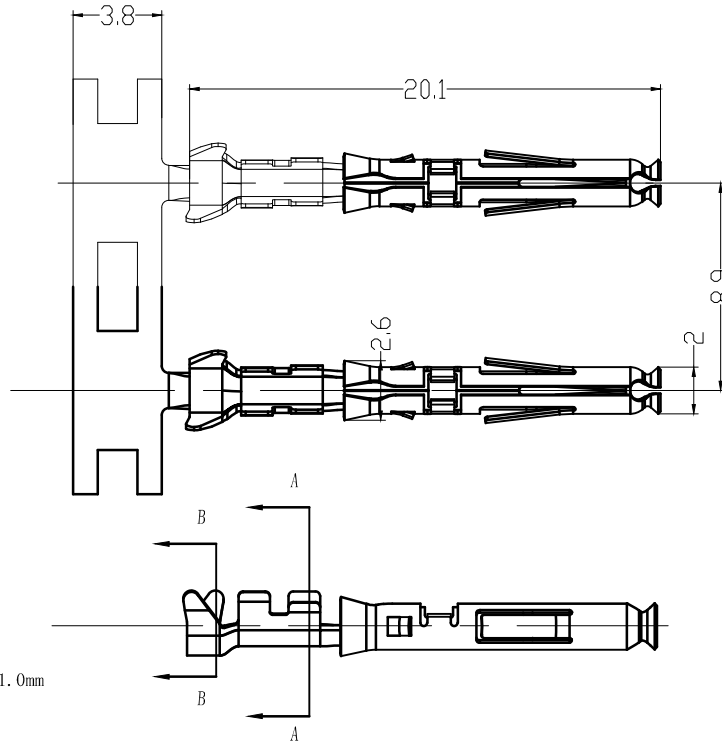

SECTION B-B

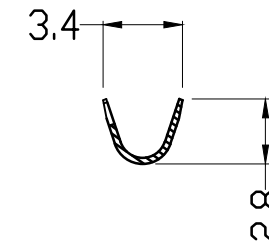

SECTION A-A

注(NOTES):

- 对配公端直径 Suitable pin diameter:1.0mm
- 额定电流 Current rating: 5A
- 端子类型 Terminatin type: Crimp
- 压线规格: AWG20~22
- 电镀信息 Plating specification: See below
  - 当 XX=01 镍底, 整个端子飘金.  
When XX=01 Gold flash plate overall.
  - 当 XX=02 镍底, 接触位置镀金10u"  
When XX=02 Contact plating 10u"
  - 当 XX=03 镍底, 接触位置镀金30u"  
When XX=03 Contact plating 30u"
  - 当 XX=04 镍底镀锡  
When XX=04 Tin over nickel
- 材料规格 Material specification:
  - 端子: 铜合金  
Contact body: Copper alloy
  - 外套: 不锈钢  
Oter spring: Stainless steel
- 符合ROHS  
ROHS compliance

		Amphenol Technical Products International GZ				PART NAME: HC Contact 20/Socket 20~22AWG	
		第三角投影 THIRD ANGLE PROJECTION	页面 SHEET	幅面 SIZE	版次 REV.	比例 SCALE	DWG NO: HCTF120XX
签名 SIGNATURE		日期 DATE	UNLESS OTHERWISE SPECIFIED			CUST PART #: N/A	
制图 DRAWN	RW	12/01/14	1) All dimensions are in metric(mm). 2) Tolerances are as follows:			CUST REV. -	
审核 CHECKED	GX	12/01/14	0 PL DEC ±1.00 1 PL DEC ±0.50 2 PL DEC ±0.20				
批准 APPROVAL	EC	12/01/14	Angles ±1°				