

NOTE(S):

- MATERIAL: Cu ALLOY WITH TENSILE STRENGTH > 600 N/mm<sup>2</sup> ELECTRICAL CONDUCTANCE > 30 Sm/mm<sup>2</sup> (>50% IACS)
- BASE PLATING: 2-3.5µm Ni ALL OVER TIN PLATING: 2.5-4µm Sn GOLD PLATING: >0.8µm Au
- CONTACT MUST BE FREE OF BURRS AND SHARP EDGES.
- ALL EDGES RADIUSUED WITH R0.1-R0.2 IN THIS AREA.
- TIN AND GOLD PLATING AREA.
- PIN ROTATION ±5° MAXIMUM.

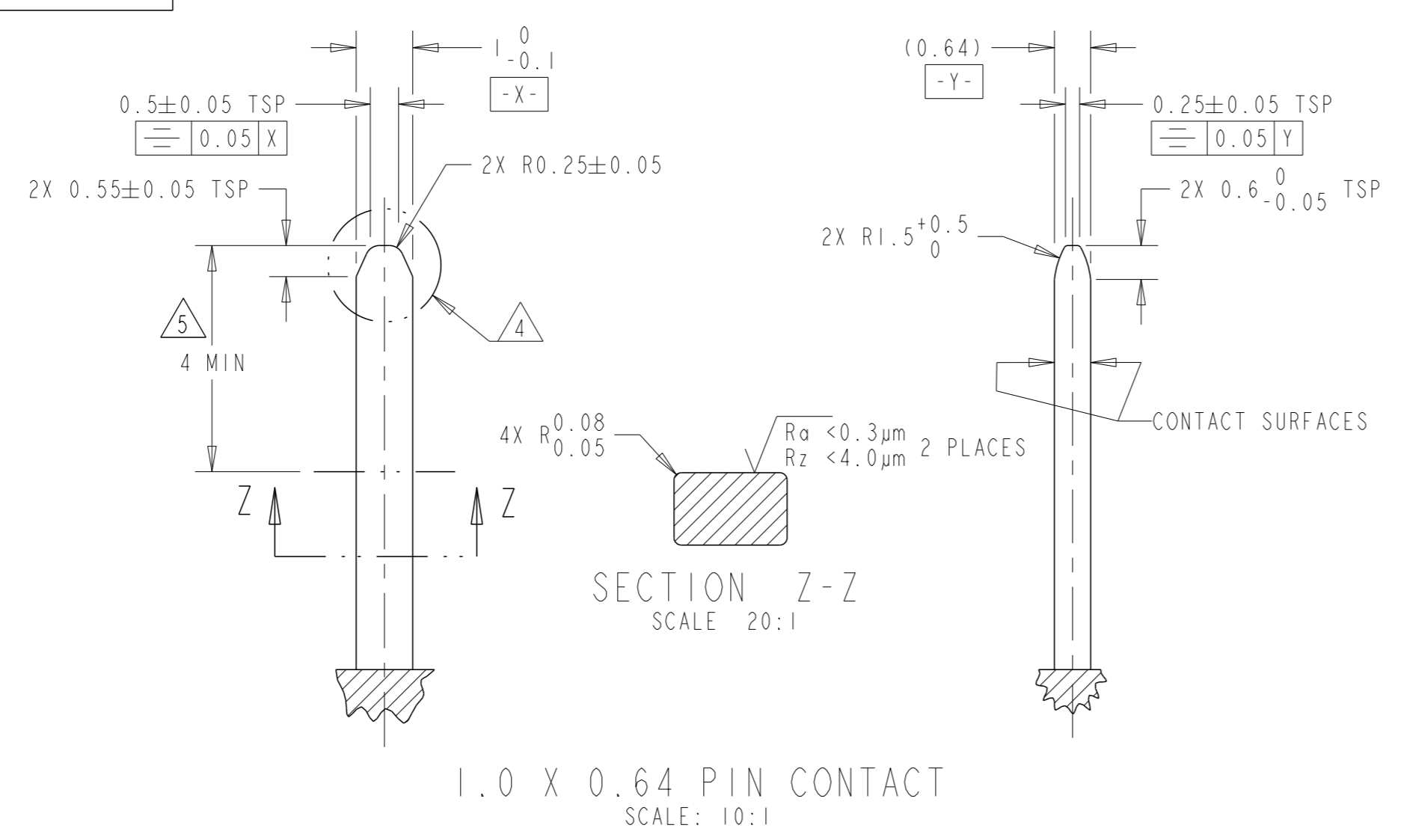

1.0 X 0.64 PIN CONTACT  
SCALE: 10:1

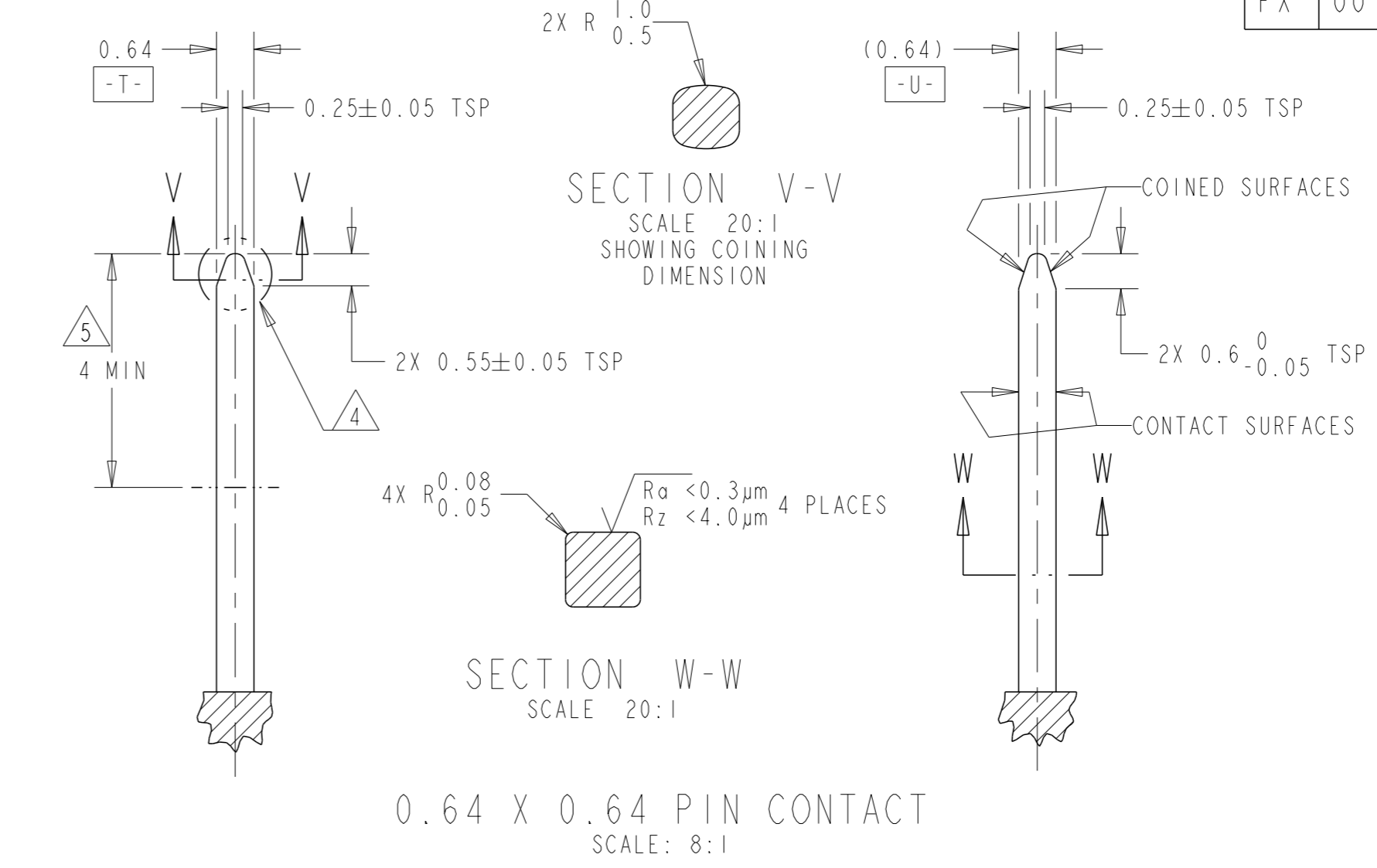

0.64 X 0.64 PIN CONTACT  
SCALE: 8:1

REVISONS		DATE	OWN	APVD
P	LY#	DESCRIPTION		
A		INITIAL RELEASE	06DEC2012	AW CM

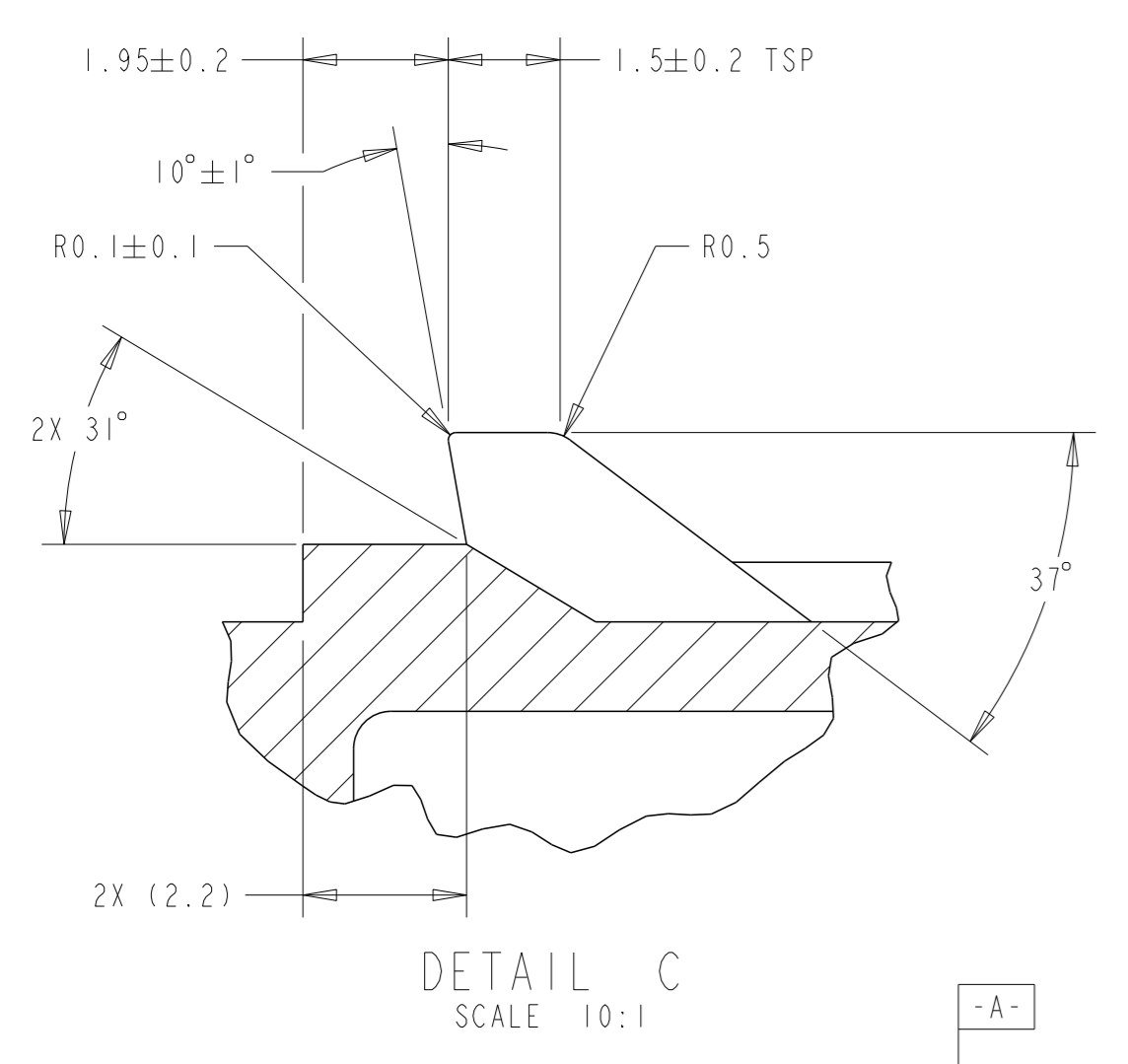

DETAIL C  
SCALE: 10:1

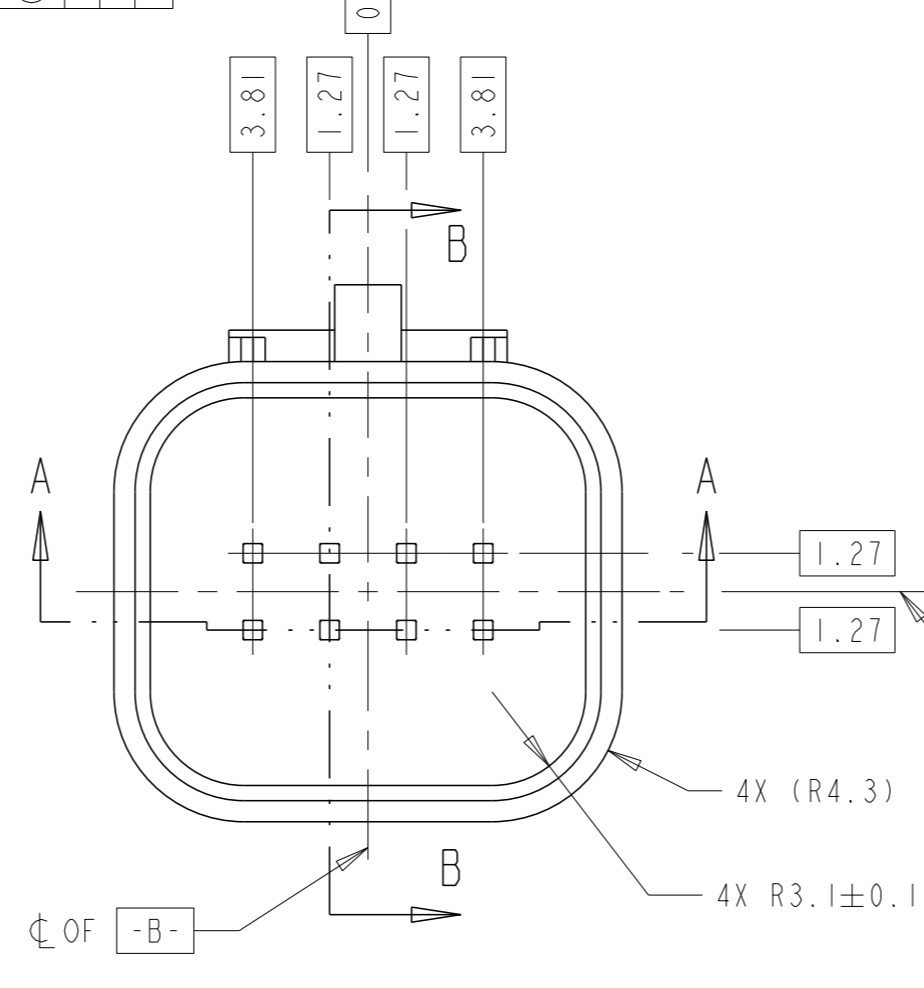
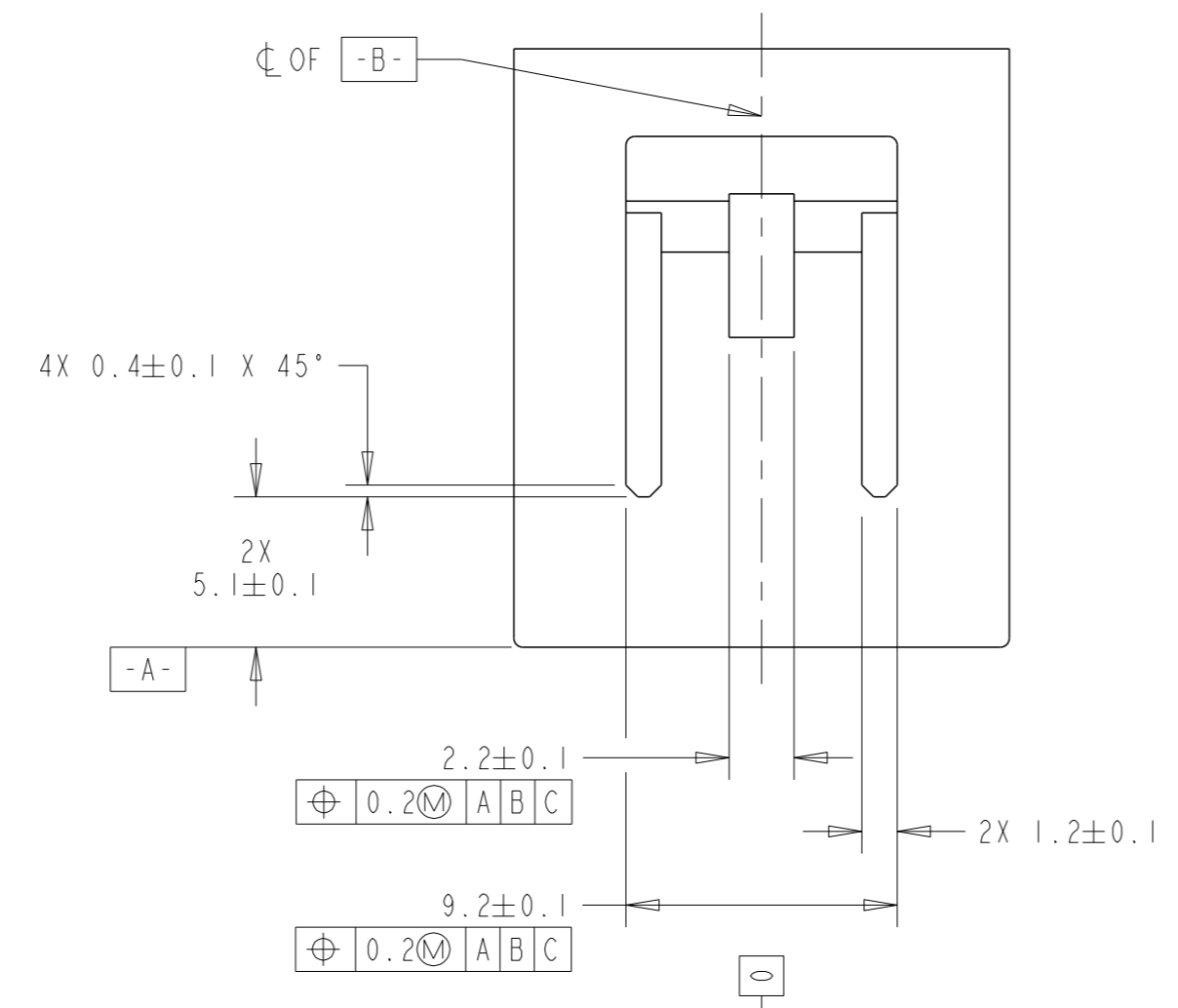

SECTION B-B

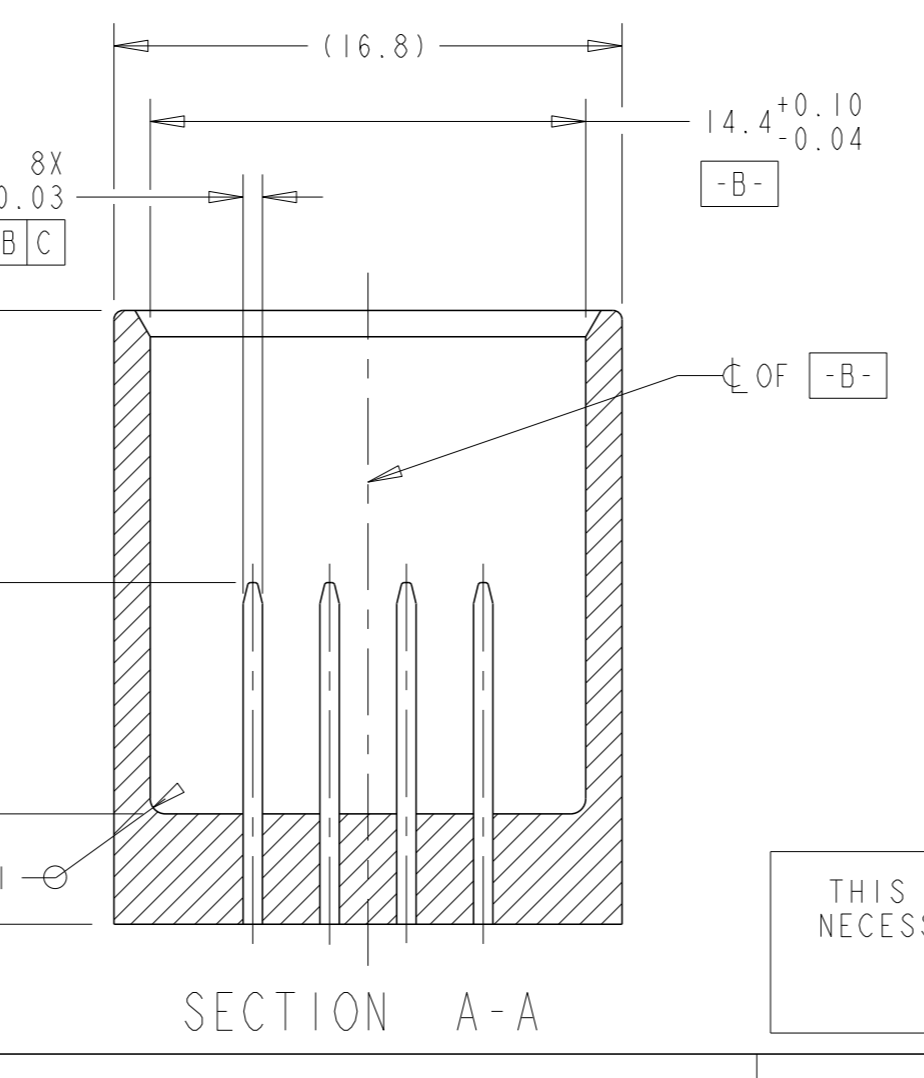
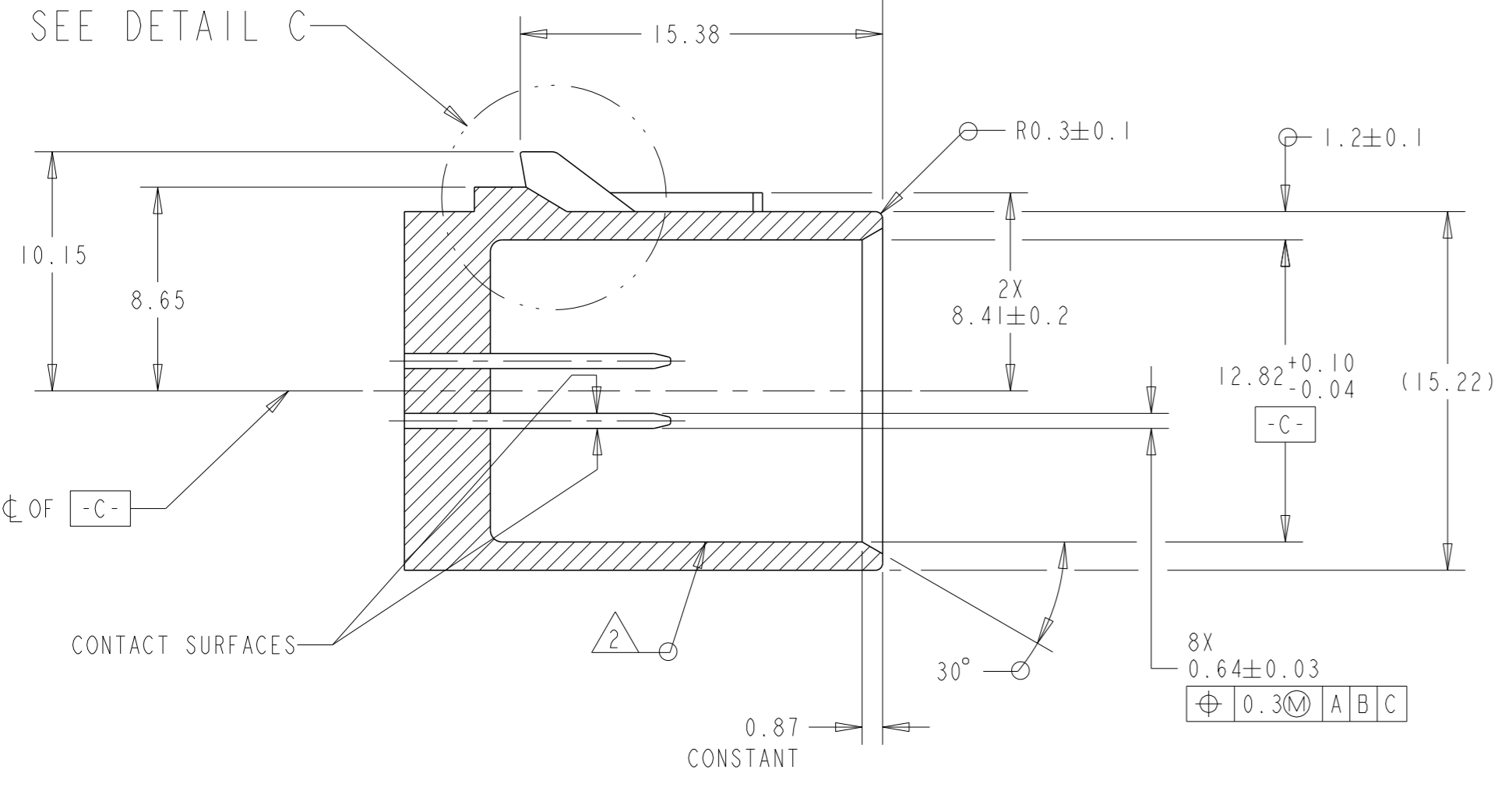

SECTION A-A

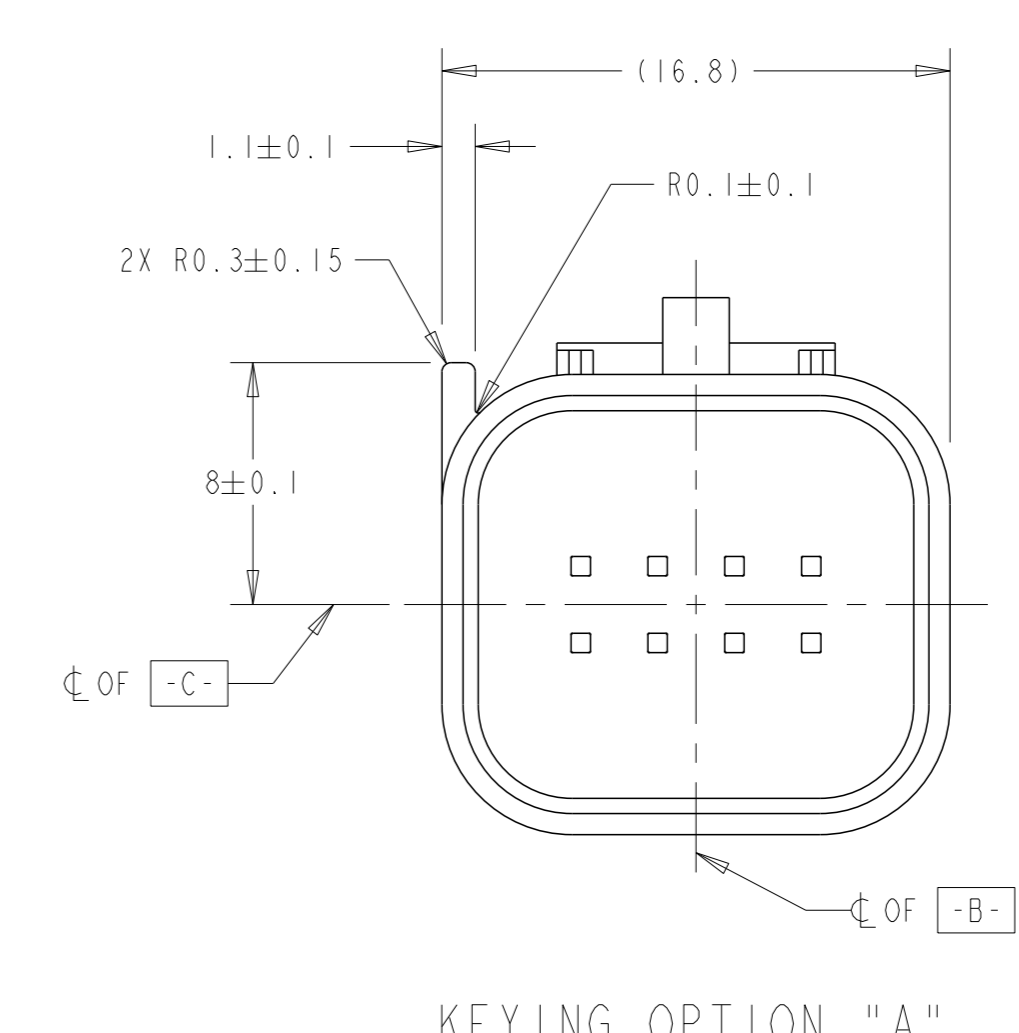
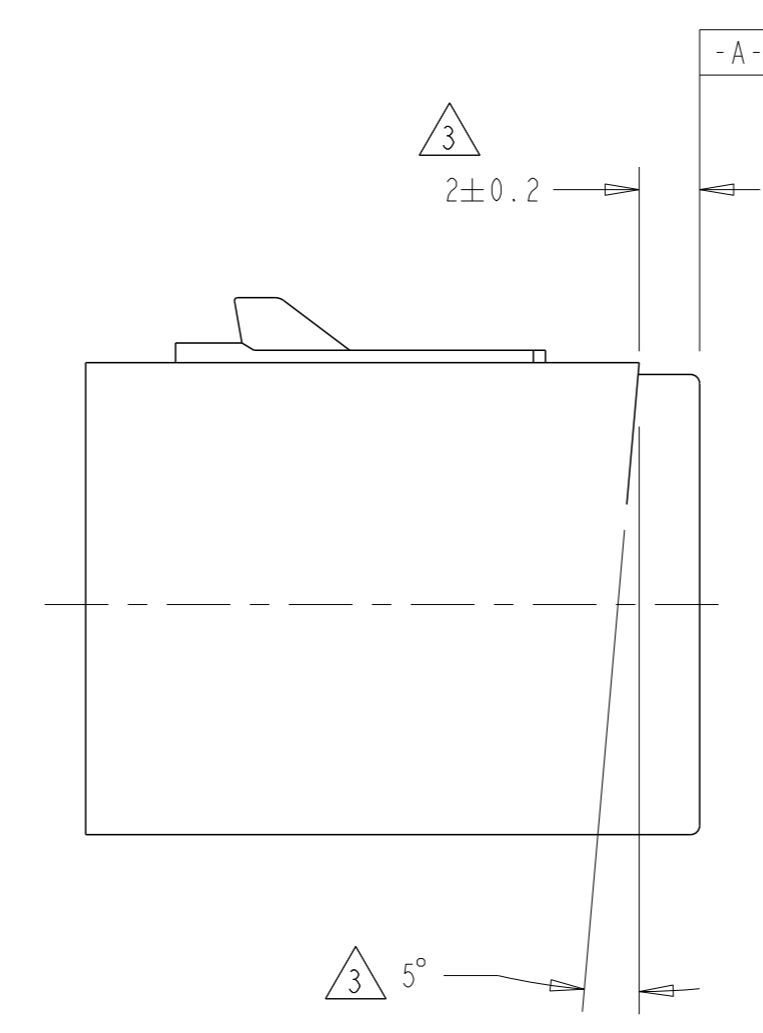

KEYING OPTION "A"

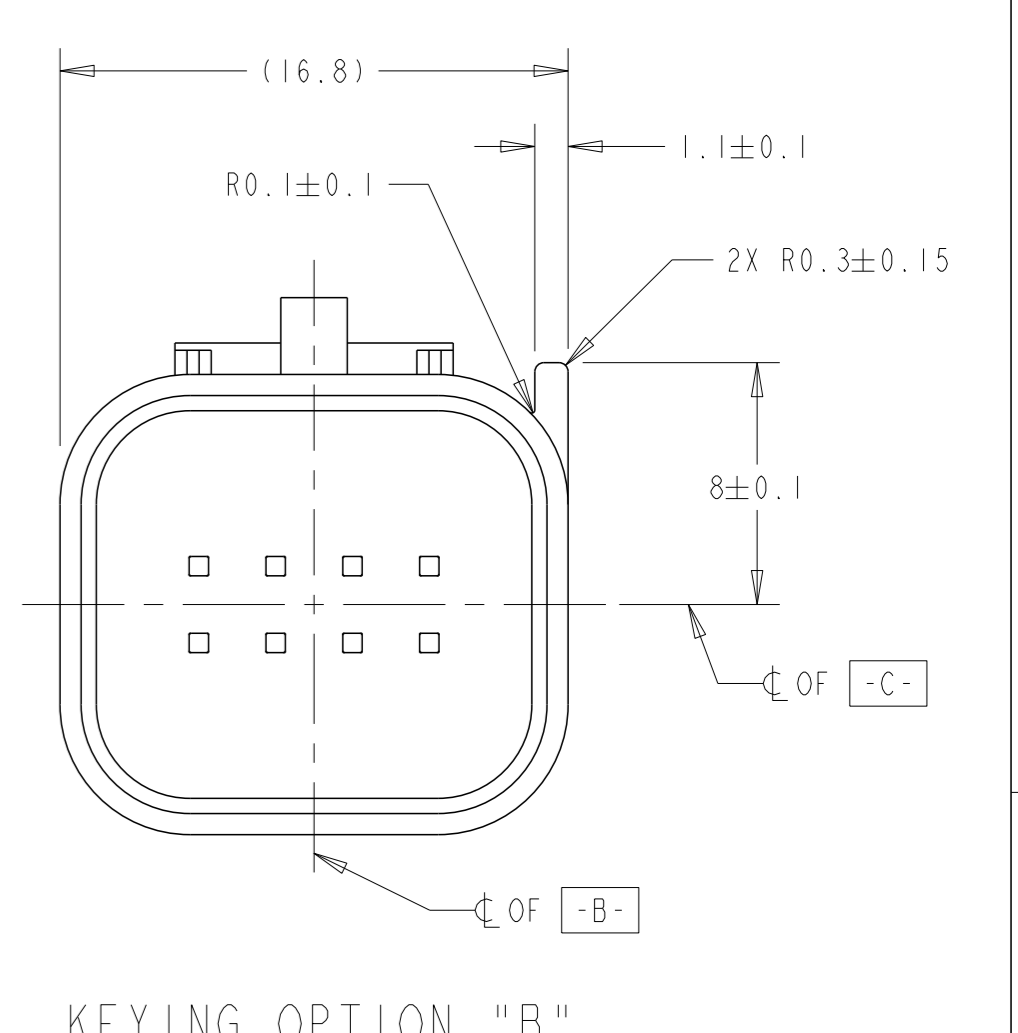

KEYING OPTION "B"

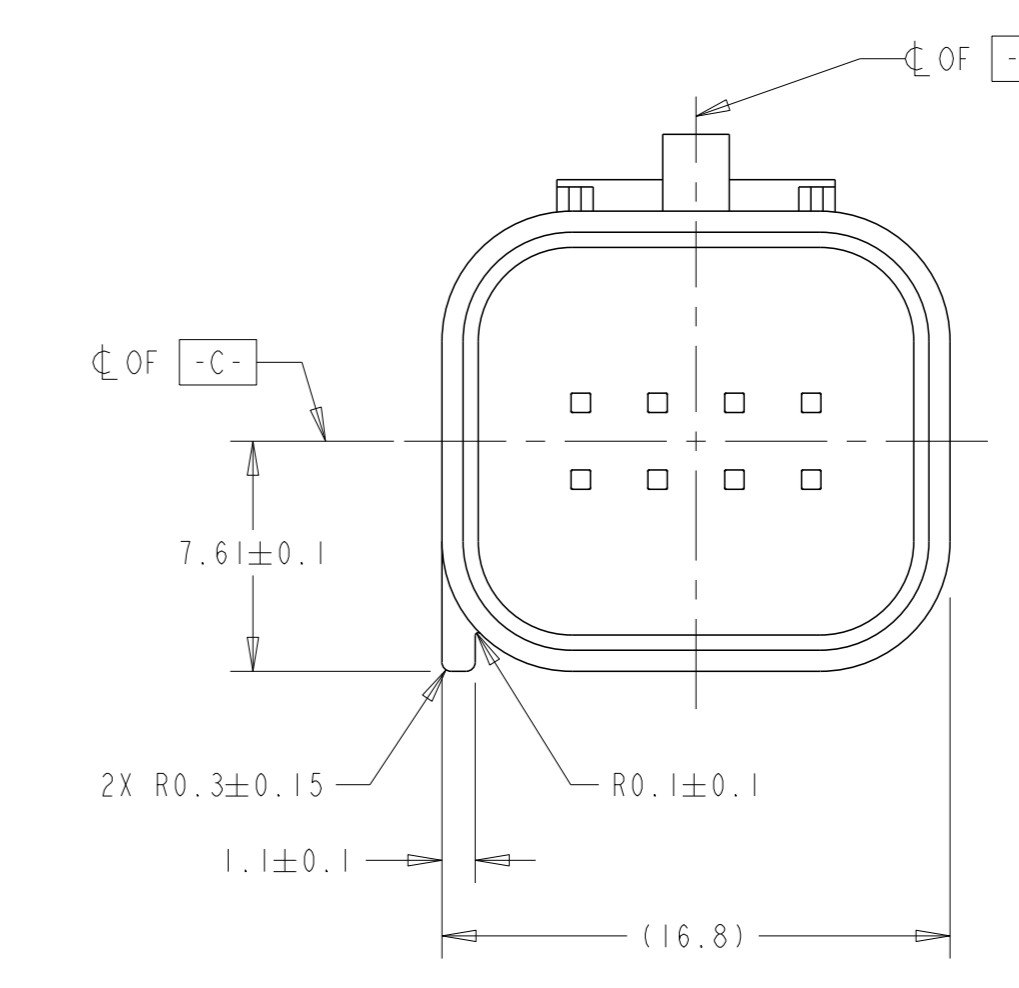

KEYING OPTION "C"

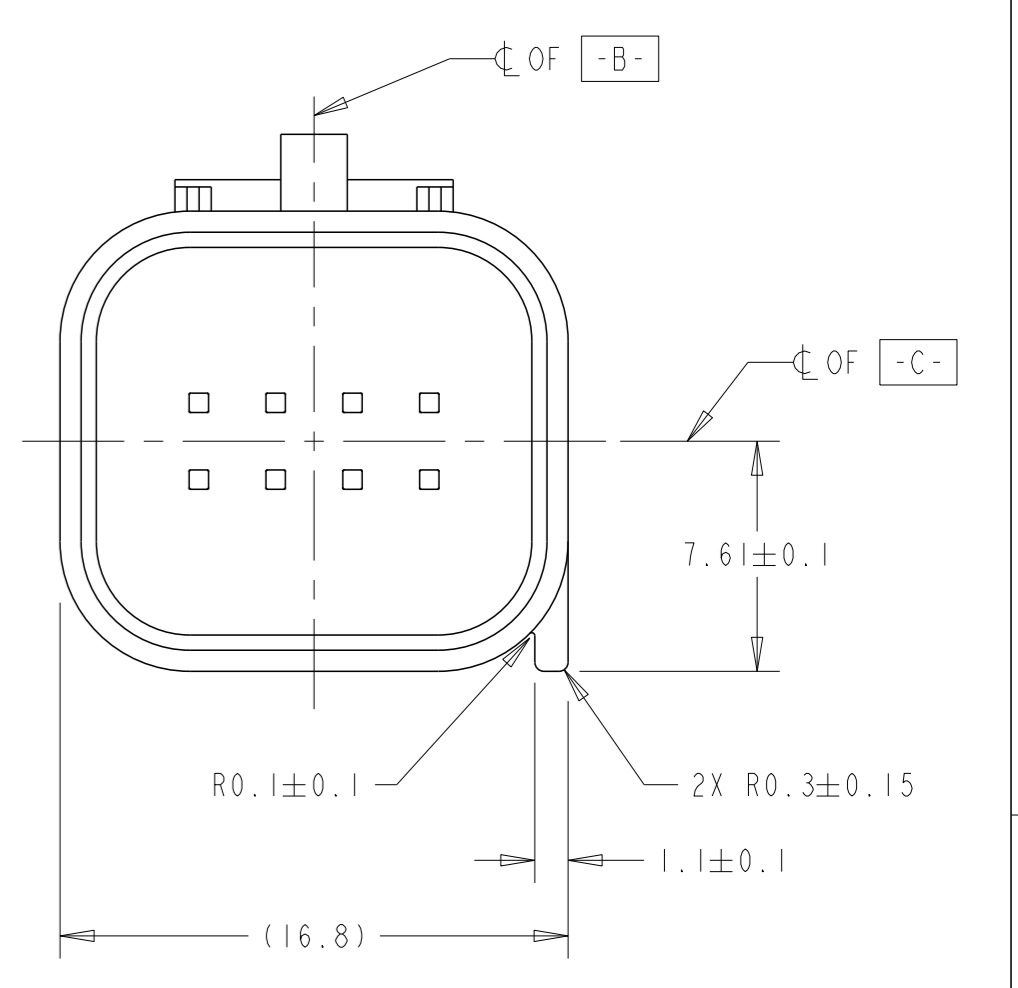

KEYING OPTION "D"

NO KEYING OPTION SHOWN

NOTE(S):

- DRAFT WITHIN TOLERANCE.
- SEALING SURFACE, NO WITNESS LINES OR DAMAGE PERMITTED.
- THIS DIMENSION APPLIES TO ALL KEYING OPTIONS.

THIS DRAWING DEFINES THE DIMENSIONAL INTERFACE REQUIREMENTS NECESSARY FOR DEVELOPING AN INSERT MOLDED CONNECTION TO MATE WITH PLUG CONNECTORS PROVIDED BY TE CONNECTIVITY. MATES WITH TE PART NUMBER: 1411001.

THIS DRAWING IS A CONTROLLED DOCUMENT.		OWN: A. WEBSTER 06DEC2012	TE Connectivity
DIMENSIONS: mm		CHK: C. MARTIN 06DEC2012	
TOLERANCES UNLESS OTHERWISE SPECIFIED:		APVD: C. MARTIN 06DEC2012	NAME: INTERFACE DRAWING
0 PLC	±	PRODUCT SPEC	2 X 4 SEALED
1 PLC	±0.3	APPLICATION SPEC	VIBRATION ROBUSTNESS
2 PLC	±0.10	WEIGHT	SIZE: A1
3 PLC	±	Customer Drawing	CAGE CODE: 00779
4 PLC	±		DRAWING NO: 2203519
ANGLES	±		SHEET 1 OF 2
FINISH	±		REV A

LOC	DIST	REVISIONS			
		REV	DATE	BY	APPV
FX	00	-	-	-	-
		SEE SHEET 1			

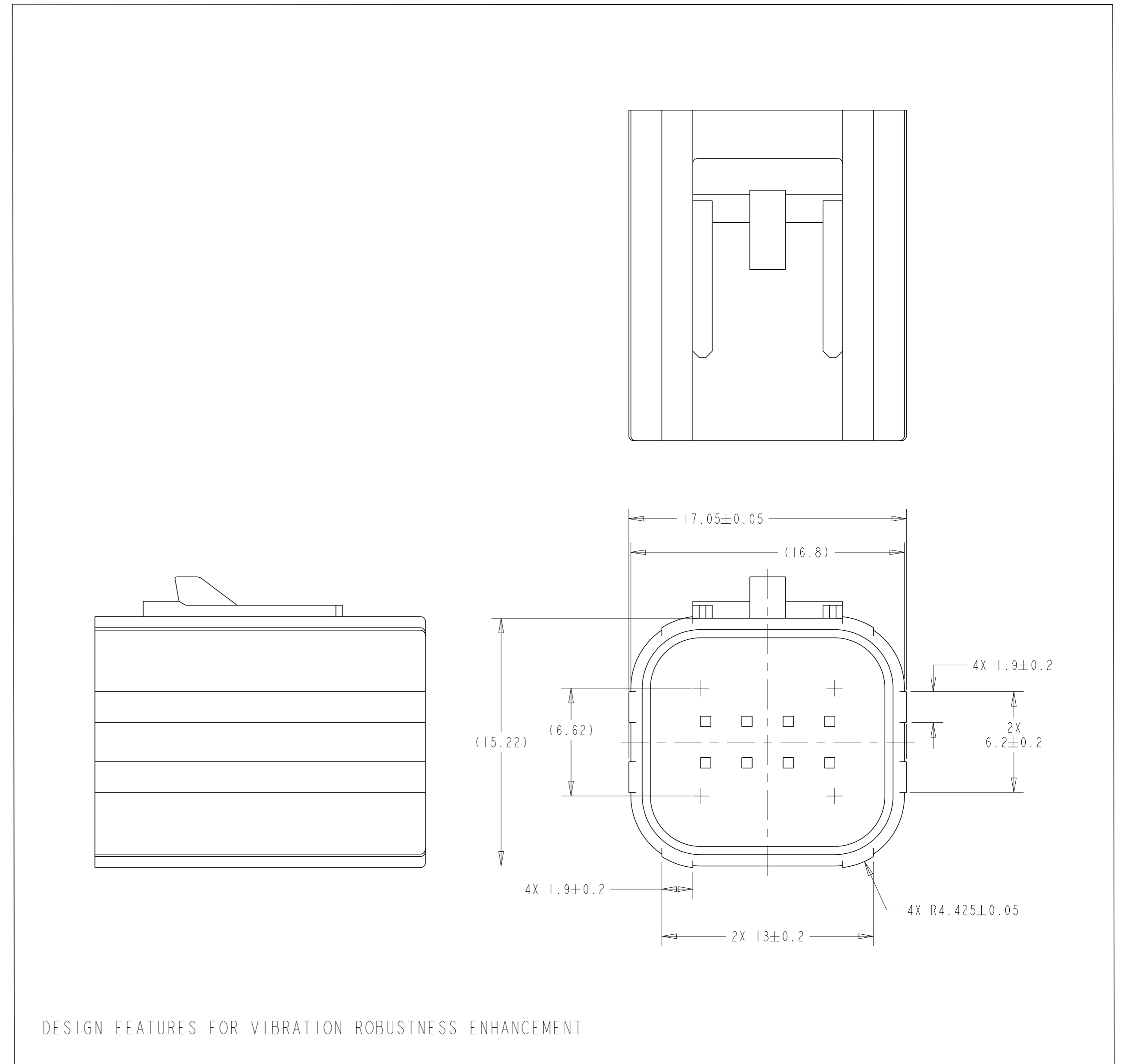
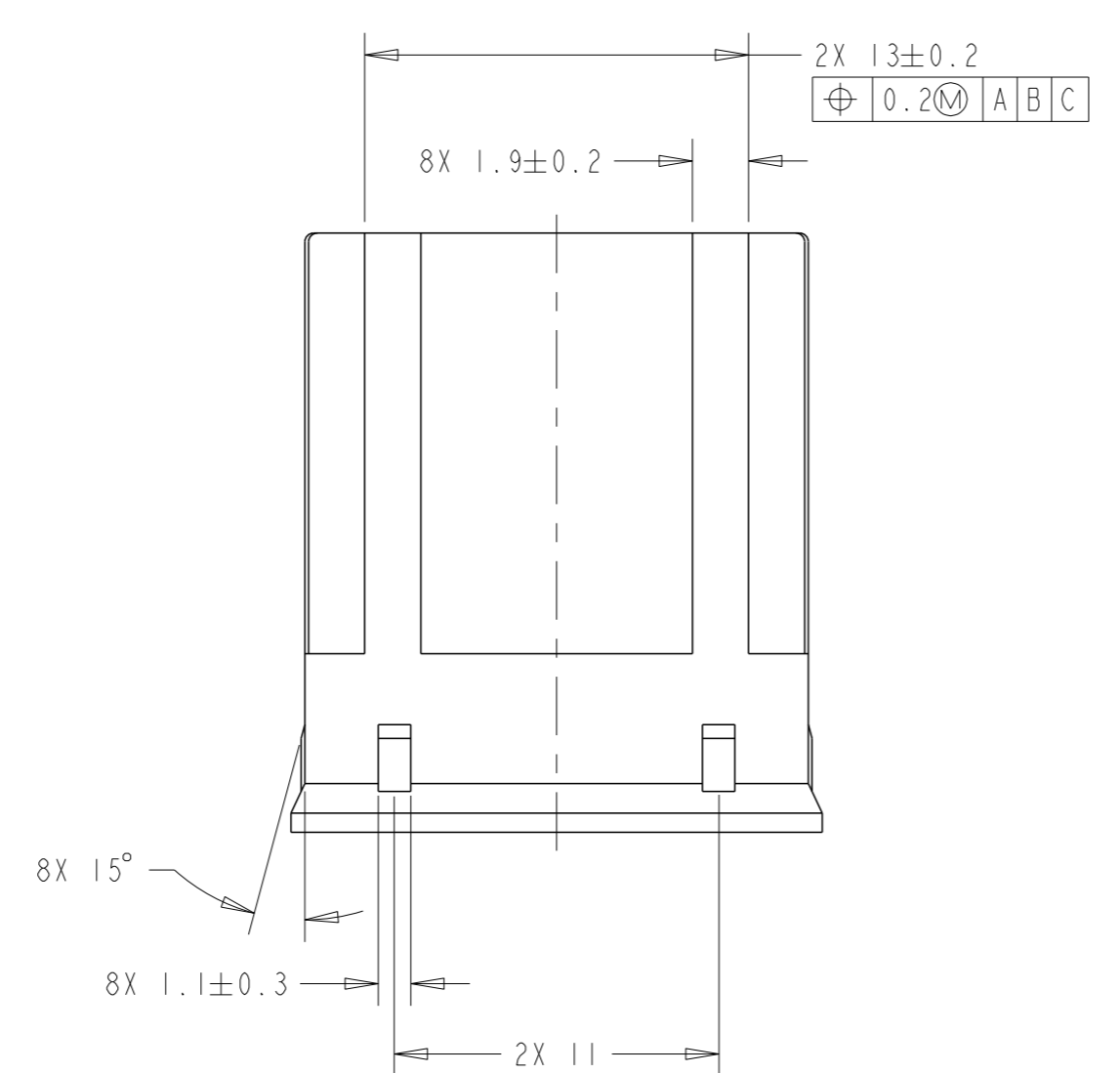
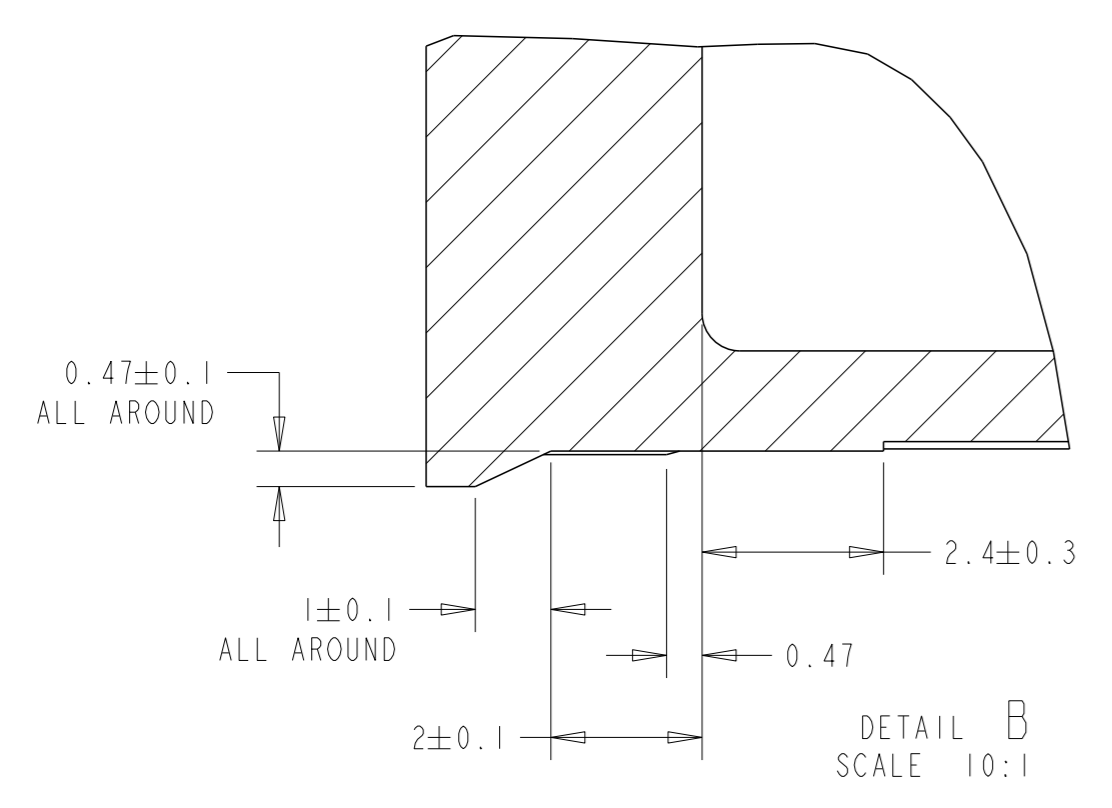
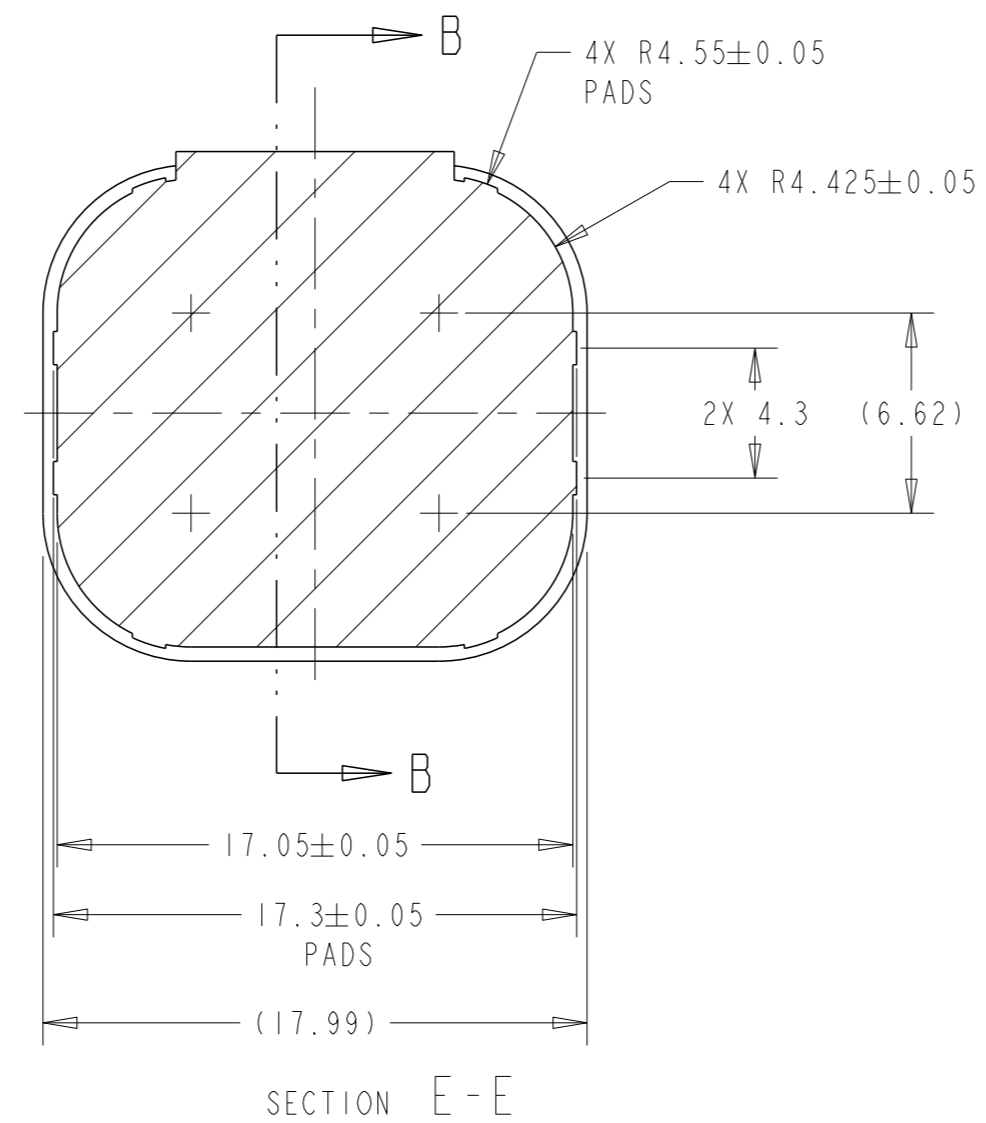
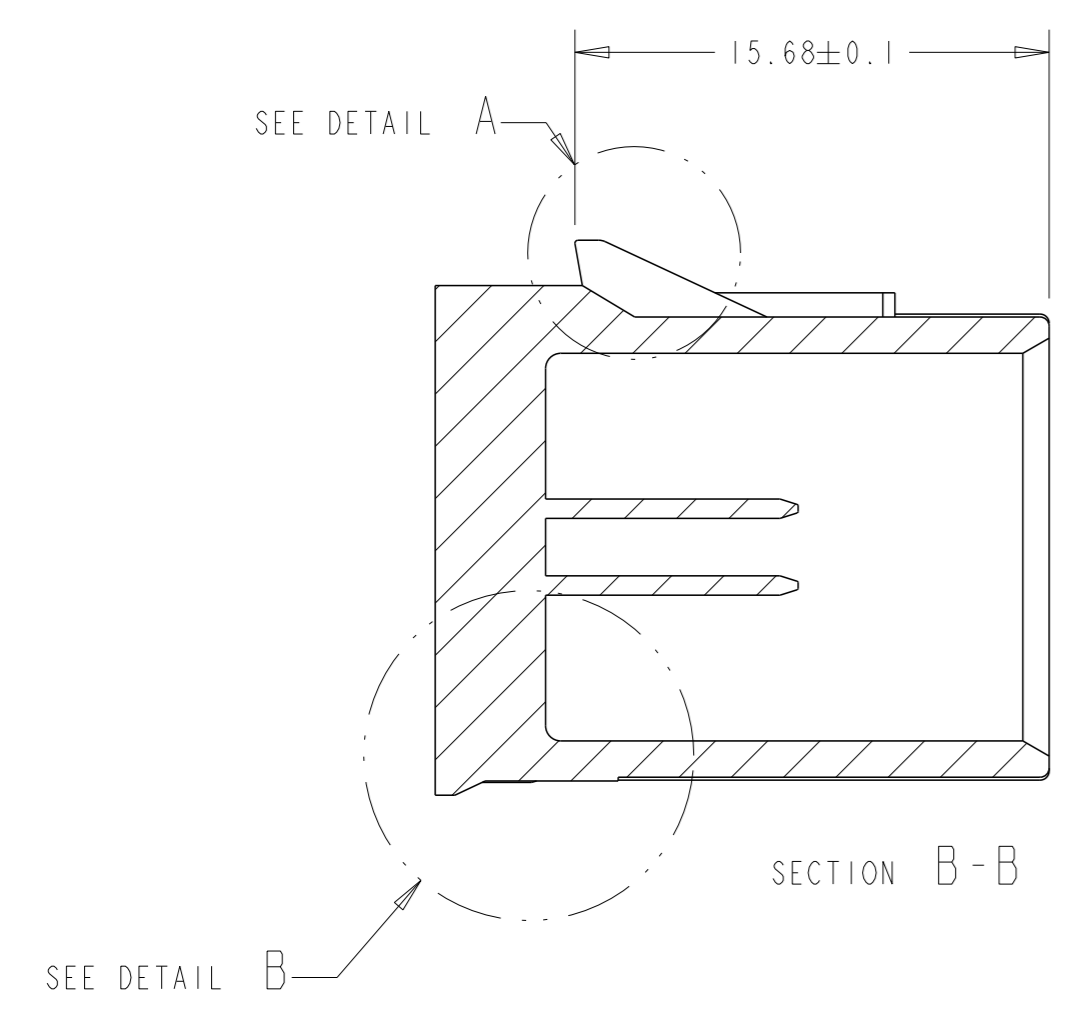
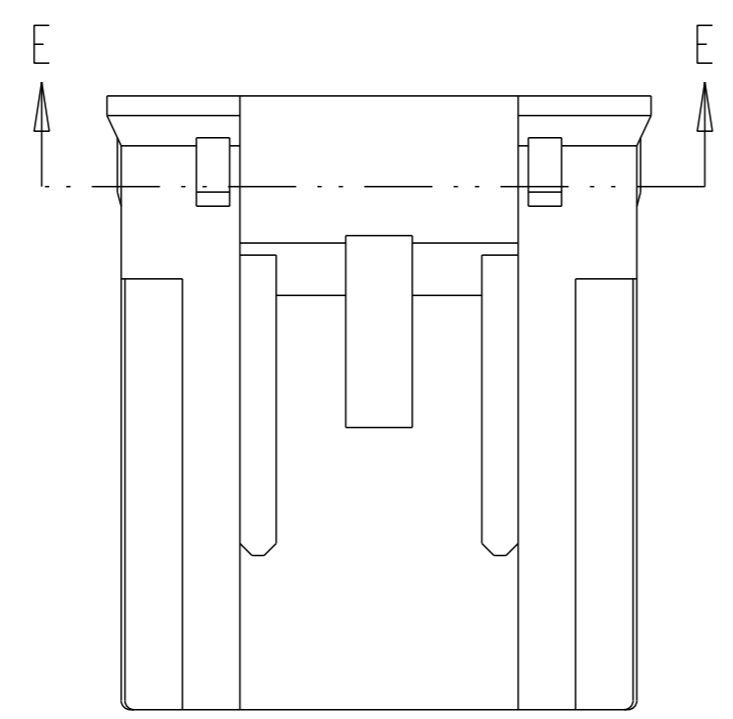
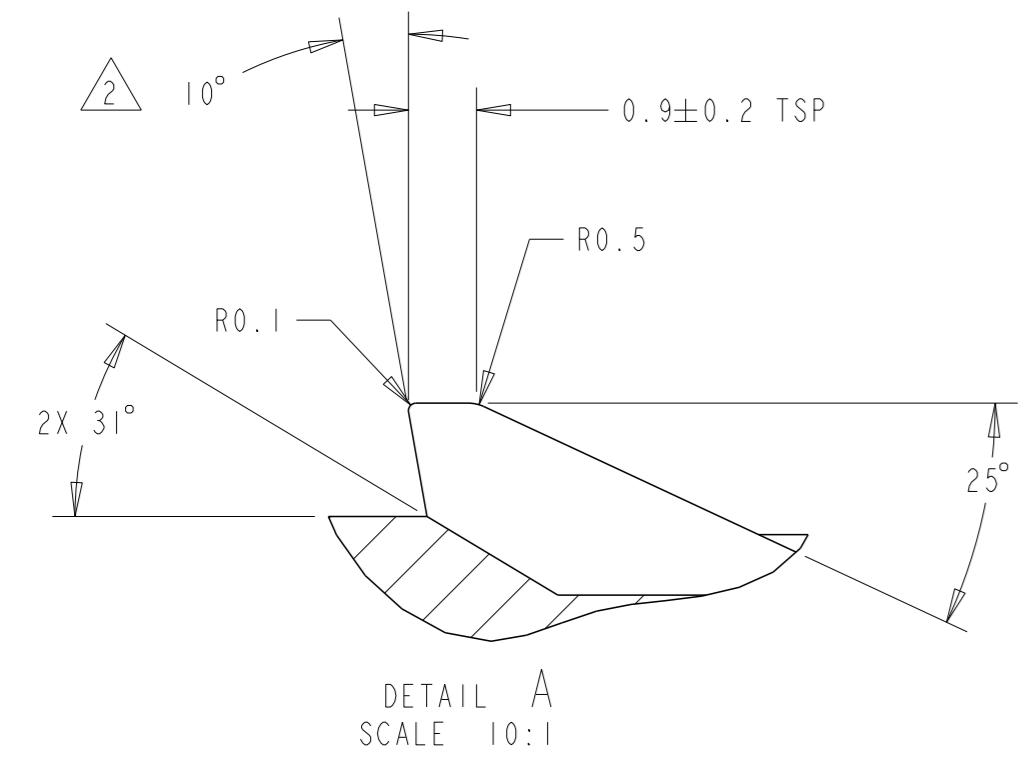

NOTE(S). UNLESS OTHERWISE SPECIFIED

- SEE APPLICABLE HEADER INTERFACE FOR ALL OTHER DIMENSIONS AND DETAILS.

THIS BACK ANGLE IS REQUIRED TO MEET THE CONNECTOR RETENTION FORCE SPECIFICATION WITH ALL ASSEMBLIES ON THE DRAWING NO. 1-1419168-1.

IMPROVED DESIGN FEATURES FOR VIBRATION ROBUSTNESS ENHANCEMENT

THIS DRAWING IS A CONTROLLED DOCUMENT.		OWN: A. WEBSTER 06DEC2012	TE Connectivity
DIMENSIONS: mm		CHK: C. MARTIN 06DEC2012	
TOLERANCES UNLESS OTHERWISE SPECIFIED:		APVD: C. MARTIN 06DEC2012	NAME: INTERFACE DRAWING
0 PLC ±	1 PLC ±0.3	PRODUCT SPEC	2 X 4 SEALED
2 PLC ±0.10	3 PLC ±	APPLICATION SPEC	VIBRATION ROBUSTNESS
4 PLC ±	ANGLES ±	WEIGHT	SIZE: A1
FINISH ±	FINISH ±	SCALE: 4:1	CAGE CODE: 00779
MATERIAL		Customer Drawing	DRAWING NO: 2203519
			SHEET 2 OF 2
			REV A

# Mouser Electronics

Authorized Distributor

Click to View Pricing, Inventory, Delivery & Lifecycle Information:

[TE Connectivity:](#)

[1411001-1](#)