

A 0460-204-12141

REVISIONS			
SYM	DESCRIPTION	DATE	APPROVED
N/C	NEW RELEASE PER F.O. 84719	12/9/77	<i>TS</i>
A	CHANGE PER E.O. 87560	5/11/79	<i>L. Stull</i>

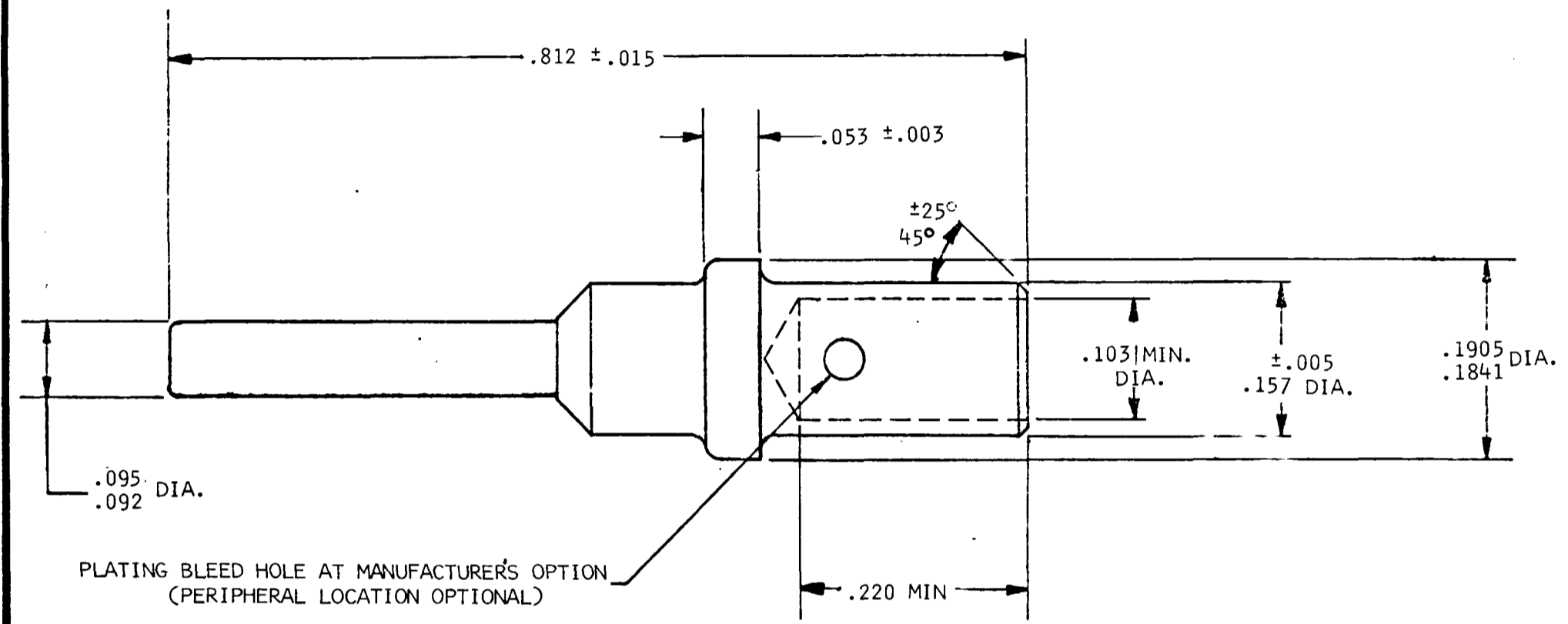

5. SUGGESTED CRIMP TOOL: PICO MODEL NO. 400, DIE ASSEMBLY 414DA12N, LOCATOR 4301-12.
 4. USABLE WIRE RANGE: 12-14 AWG, .102 MAX. CONDUCTOR DIA. RECOMMENDED STRIP LENGTH $.253 \pm .031$.
 3. CONCENTRICITY: .010 T.I.R.
 2. CONNECTOR APPLICATION: THESE CONTACTS ARE USED ON HD SERIES CONNECTORS.
- NOTE:** 1. MATERIAL: COPPER ALLOY, PLATED .000050 MIN. NICKEL PER QQ-N-290.

SIGNATURE & DATE	
DR	<i>T. Schneider</i> 12/9/77
CHK	<i>Ron von Haring</i> 12-12-77
PE	<i>J. Blum</i> 12-14-77
APPD	
SCALE	WT

CONTACT, PIN
SIZE 12
FOR HD CONNECTOR

ENVELOPE

CP	MATL CODE
The Deutsch Company ELECTRONIC COMPONENTS DIVISION Municipal Airport Banning, California	
B	0460-204-12141
DWG SIZE	CODE 11139 SHEET OF