

THIS DRAWING IS UNPUBLISHED. RELEASED FOR PUBLICATION 20
 © COPYRIGHT 20 BY TYCO ELECTRONICS CORPORATION. ALL RIGHTS RESERVED.

LOC	DIST	REVISIONS					
GP	00	P	LTR	DESCRIPTION	DATE	DWN	APVD
			B3	ADDED NEW DASH NUMBERS	28JUN2021	CZ	SH

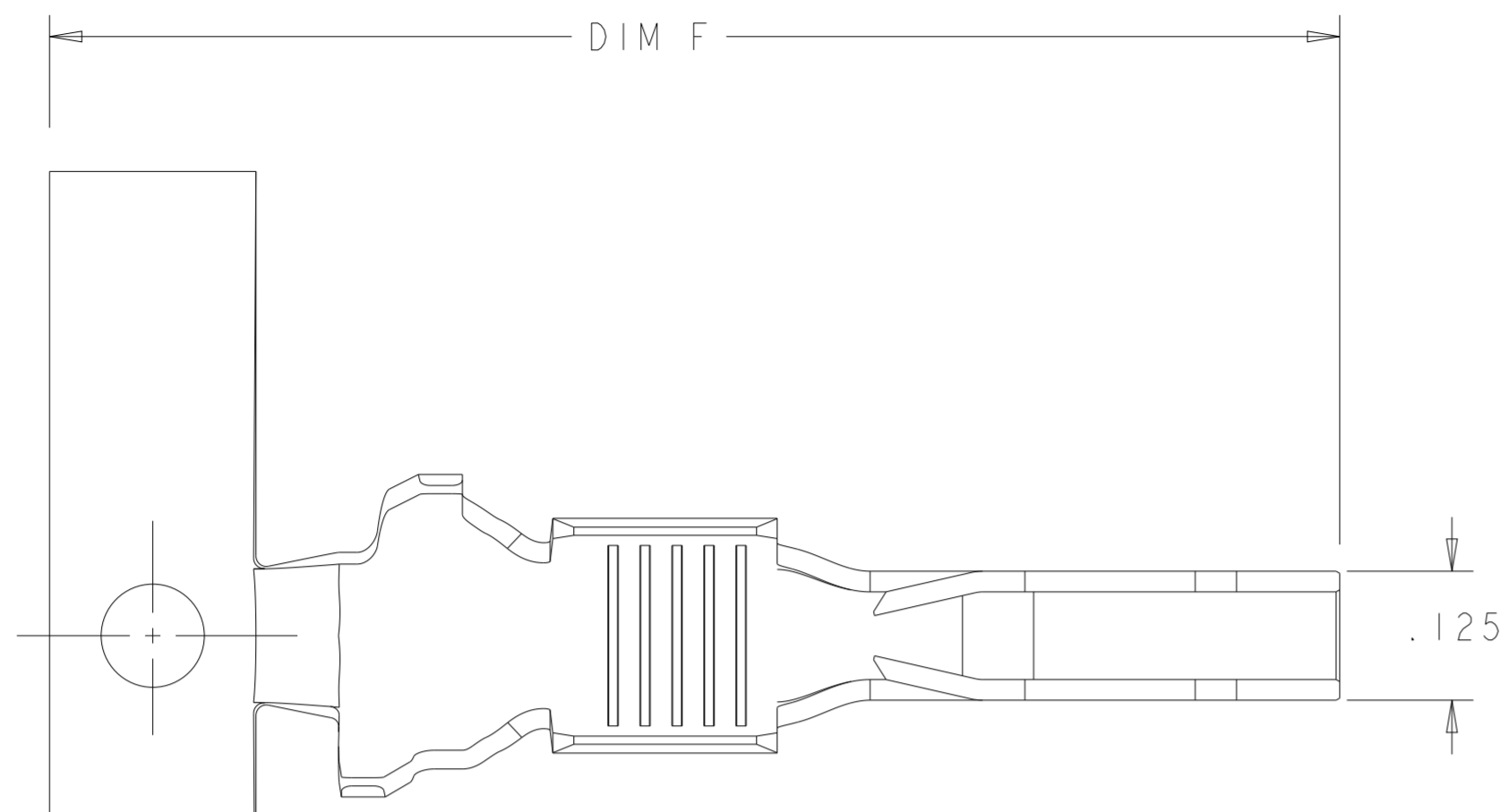

1. WIRE RANGE: 8 - 10 AWG
2. INSULATION RANGE: .176 - .272
- 3 FINISH: NICKEL PLATE ALL OVER 0.000050 MIN THICK
- 4 FINISH: NOBLE METAL PLATING ON CONTACT FUNCTIONAL AREA
- 5 FINISH: TIN IN AREA INDICATED 0.000050 - 0.000100 THK.
6. MATERIAL: HIGH CONDUCTIVITY COPPER ALLOY
- 7 FINISH: TIN-LEAD IN AREA INDICATED 0.000050 - 0.000100 THK.

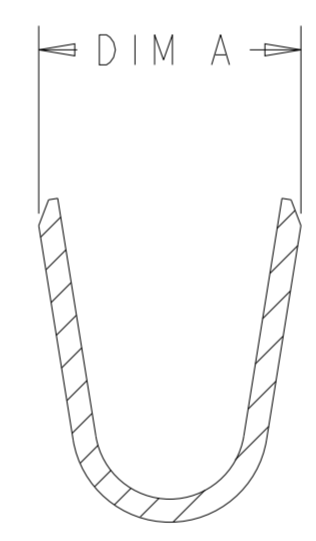
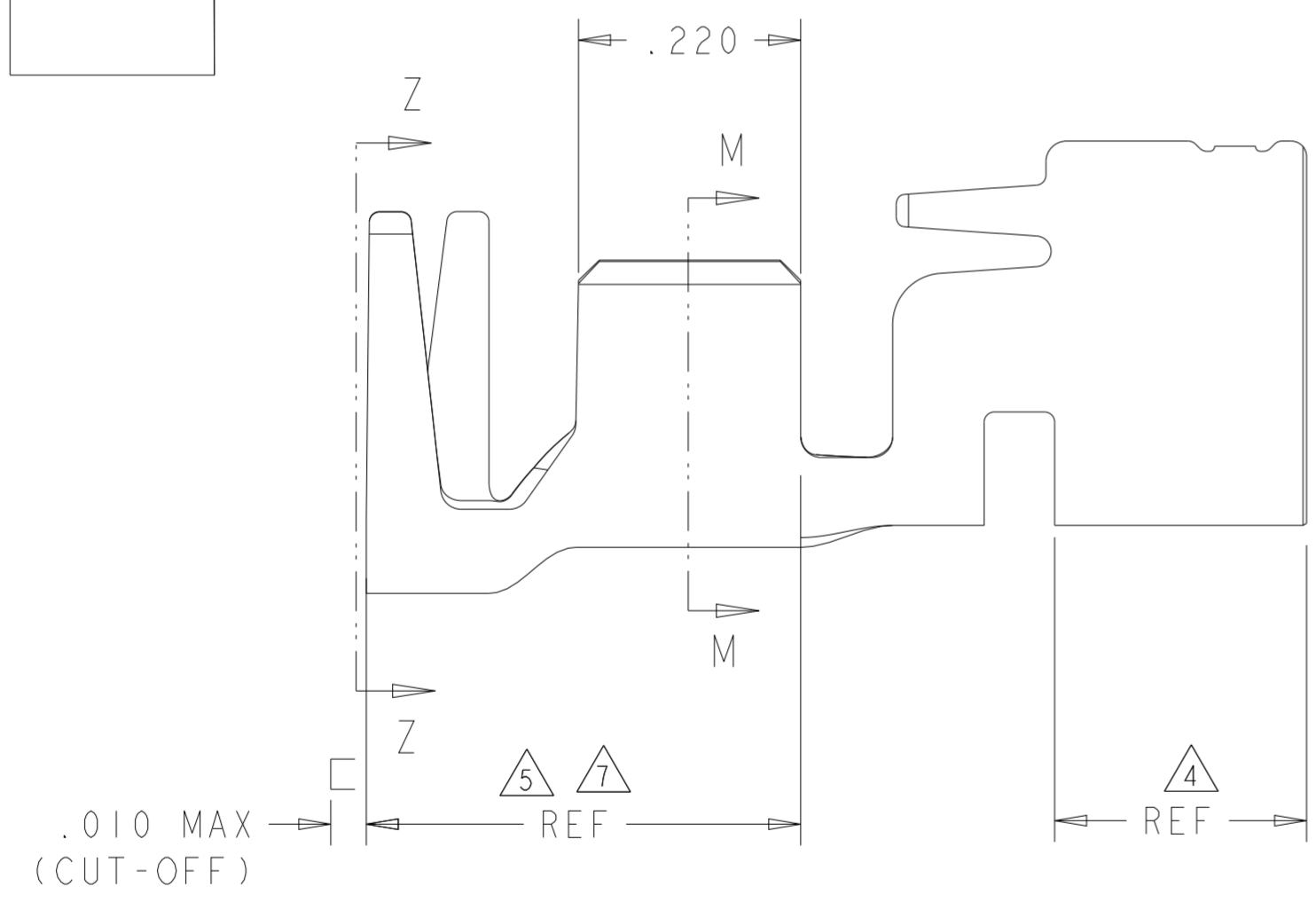

SECTION M-M

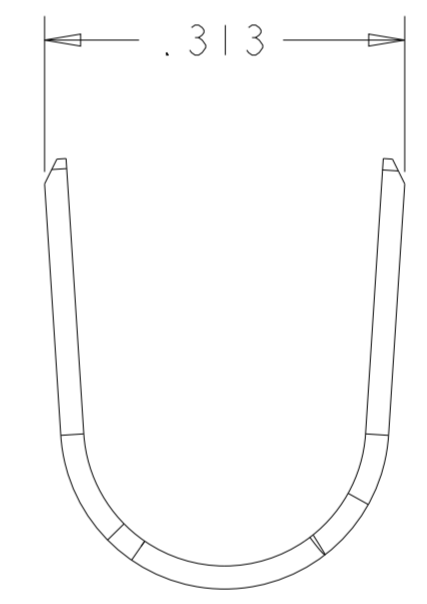

SECTION Z-Z

.315	1.200	3 4 5	STD	2-1600960-4
.315	1.250	3 4 5	MFBL	2-1600960-1
.228	1.200	3 4 5	STD	1-1600960-8
.228	1.250	3 4 5	MFBL	1-1600960-7
.228	1.200	3 4 7	STD	1-1600960-0
.228	1.250	3 4 7	MFBL	1600960-9
DIM A	DIM F REF	FINISH	DESCRIPTION	PART NUMBER

<small>THIS DRAWING IS A CONTROLLED DOCUMENT FOR TYCO ELECTRONICS CORPORATION. IT IS SUBJECT TO CHANGE AND THE CONTROLLING ENGINEERING ORGANIZATION SHOULD BE CONTACTED FOR THE LATEST REVISION.</small>		DWN 19 JAN 2005 R. GRZYBOWSKI CHK P. D'AMATO APVD P. D'AMATO PRODUCT SPEC 108-2157 APPLICATION SPEC 114-13112 WEIGHT - CUSTOMER DRAWING	tyco Electronics Tyco Electronics Harrisburg, PA 17105-3608
DIMENSIONS: INCHES 	TOLERANCES UNLESS OTHERWISE SPECIFIED: 0 PLC ± 1 PLC ±.10 2 PLC ±.05 3 PLC ±.005 4 PLC ±.0020 ANGLES ± FINISH SEE NOTES	NAME VERTICAL BULKHEAD CABLE RECEPTACLE POWER CONTACT MULTI-BEAM XL SIZE A2 CAGE CODE 00779 DRAWING NO C-1600960 RESTRICTED TO	SCALE 6:1 SHEET 1 OF 1 REV B3

Mouser Electronics

Authorized Distributor

Click to View Pricing, Inventory, Delivery & Lifecycle Information:

[TE Connectivity:](#)

[1-1600960-7](#)