

LOC	DIST	REVISIONS					
		P	LTH	DESCRIPTION	DATE	DWN	APVD
ES	00	L6		ADDED NEW DASH NUMBER 3-9	01MAR2016	CZ	SZ
		L7		ADDED NEW DASH NUMBER 4-0 AND 4-1	13APR2016	CZ	SZ

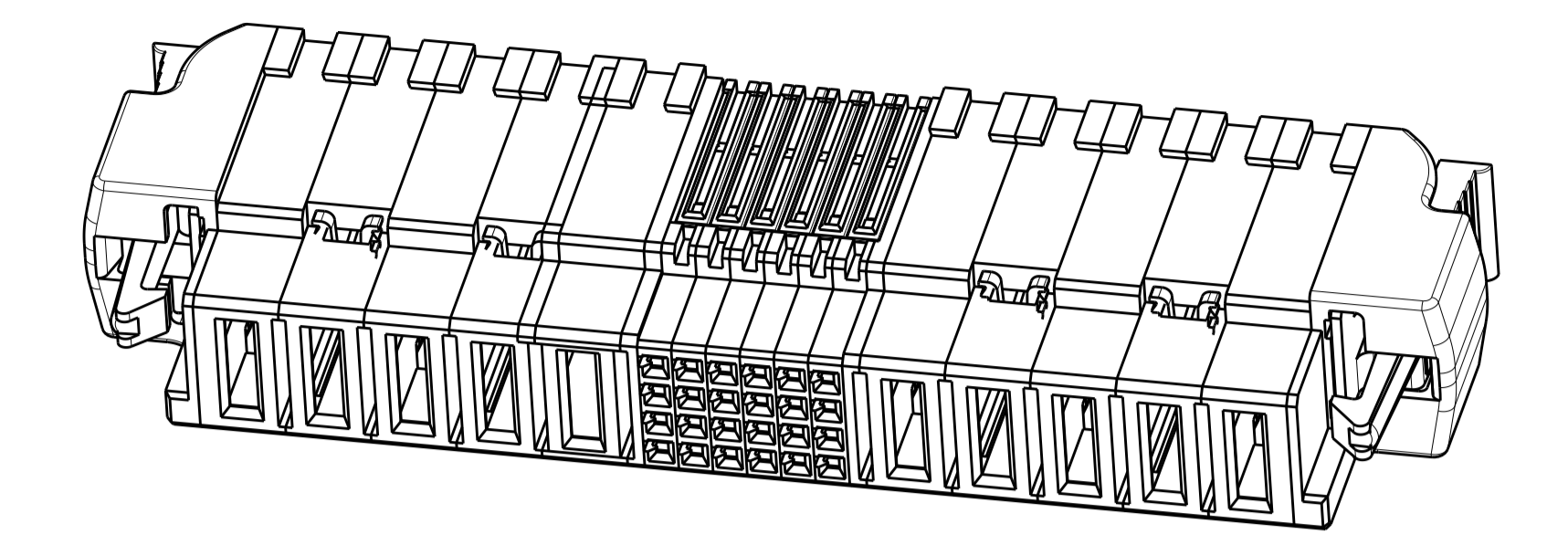

ISOMETRIC VIEW WITHOUT
OPTIONAL CENTER MODULE
SCALE 2:1

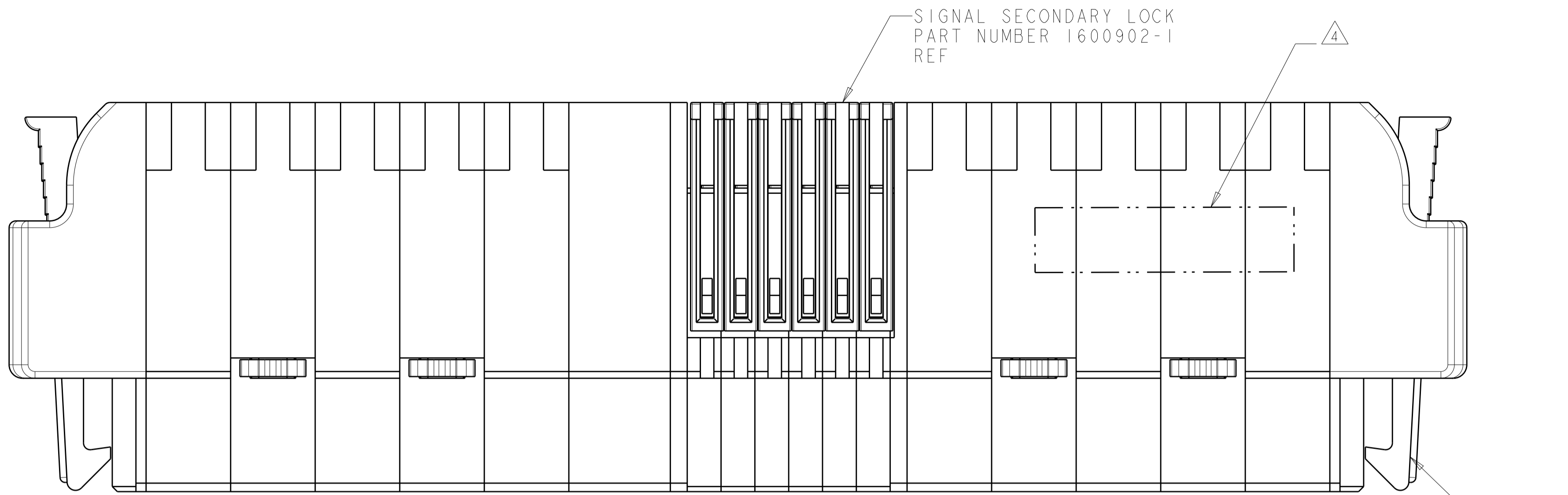
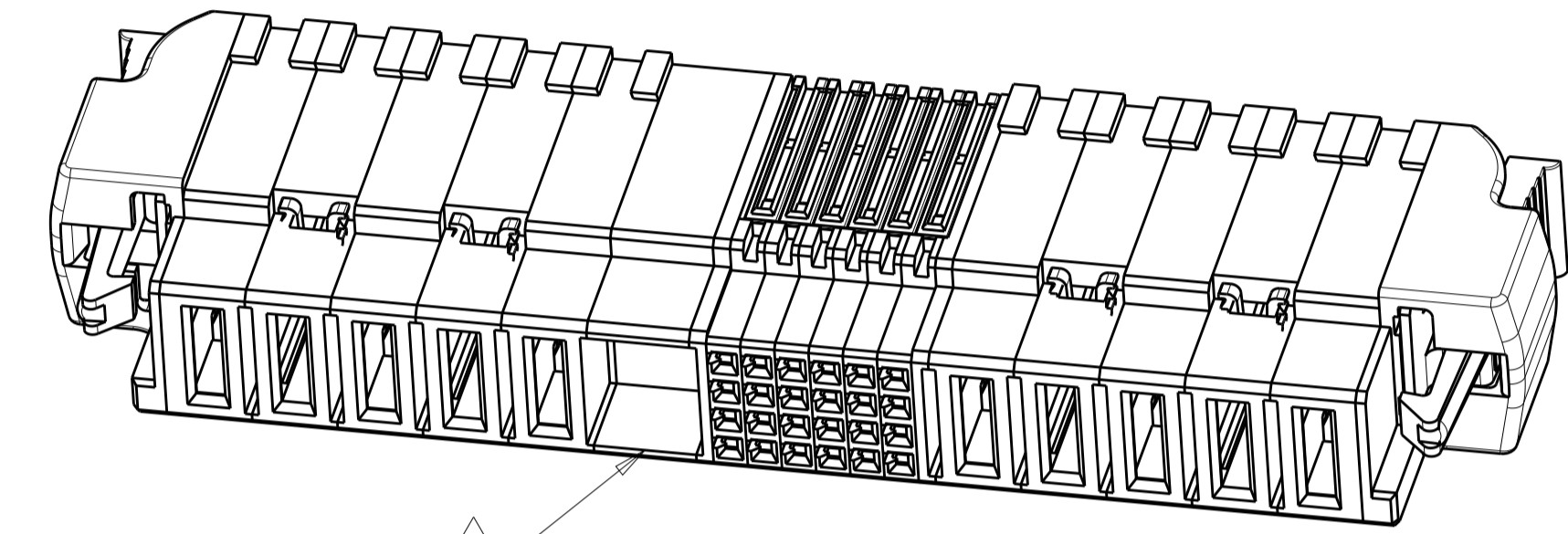

ISOMETRIC VIEW WITH
OPTIONAL CENTER MODULE
SCALE 2:1

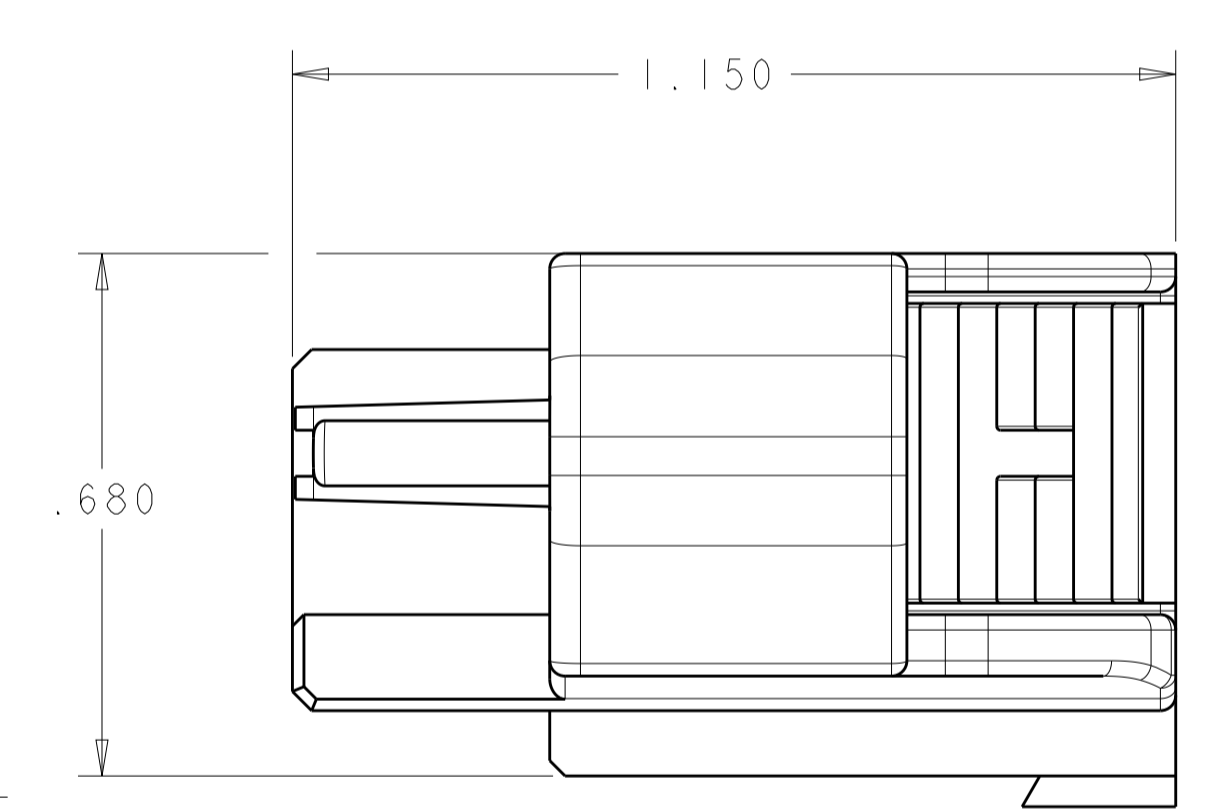
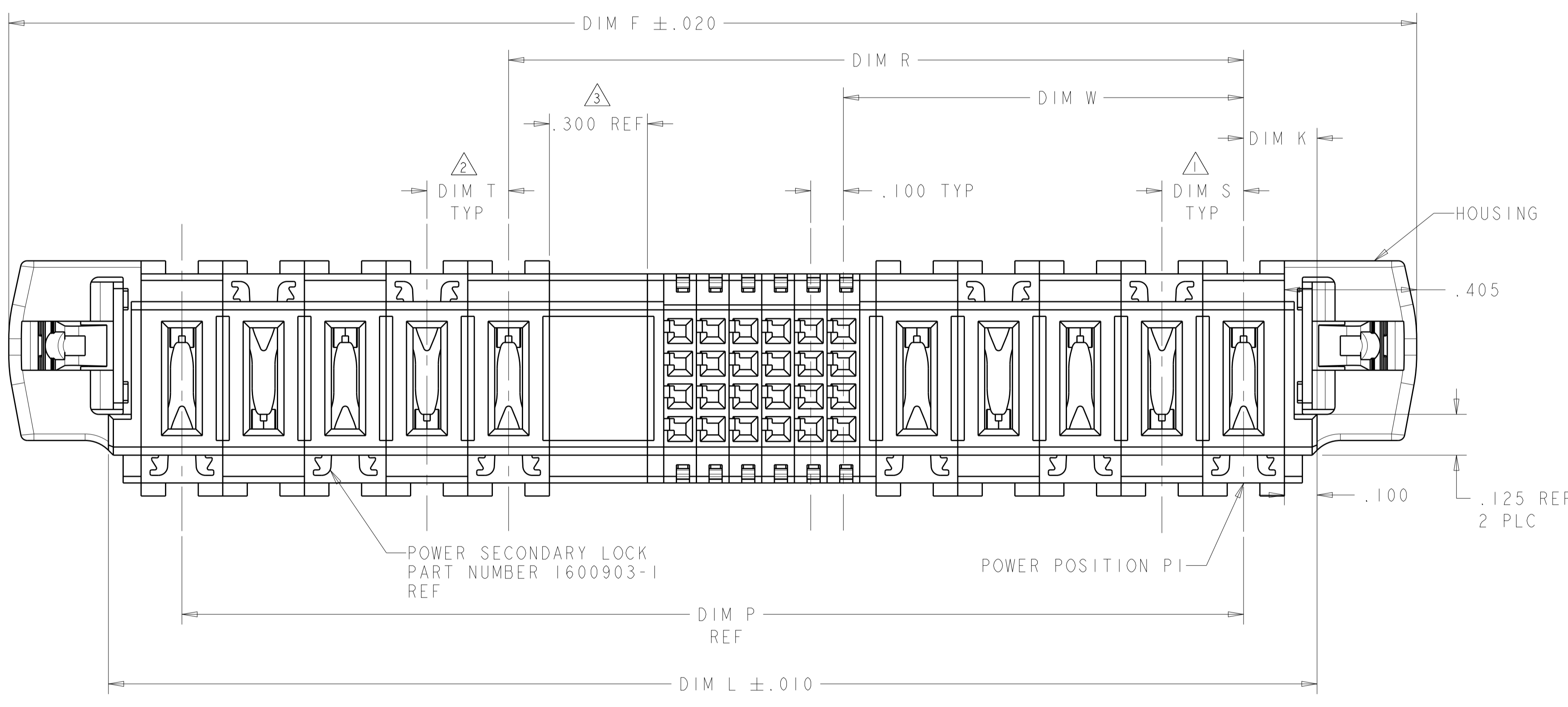

- ① DIM S IS CENTERLINE SPACING OF POWER MODULE ON RIGHT SIDE OF HOUSING.
- ② DIM T IS CENTERLINE SPACING OF POWER MODULE ON LEFT SIDE OF HOUSING.
- ③ OPTIONAL CENTER MODULE
- ④ COMPANY TRADEMARK, PART NUMBER, AND DATE CODE TO BE MARKED IN APPROX AREA SHOWN. PARTS UNDER 2.00 LONG MAY BE MARKED ON BOTH SIDES.
- ⑤ THERMO PLASTIC, UL94 V-0, BLACK
- ⑥ VARIABLE DIMENSIONS SHOWN ON VIEW (SHEET 2).
- ⑦ NOT RELEASED FOR PRODUCTION.
- ⑧ DIMENSIONS FOR CONFIGURATION "S" PLEASE REFER TO SHEET 3.
- ⑨ THE CONFIGURATION WITH VENT, PLEASE REFER TO SHEET 2.

THIS DRAWING IS A CONTROLLED DOCUMENT.		DWN R. GRZYBOWSKI CHK P. DAMATO	TOMAY05	TE Connectivity
DIMENSIONS: INCHES		APVD P. DAMATO	TOMAY05	
TOLERANCES UNLESS OTHERWISE SPECIFIED: 0 PLC \pm 1 PLC $\pm .01$ 2 PLC $\pm .005$ 3 PLC $\pm .005$ 4 PLC $\pm .0020$ ANGLES $\pm .0020$		NAME SQUEEZE TO RELEASE CABLE RECEPTACLE ASSEMBLY W/ LATCHES AND KEY, MULTI-BEAM XLE	PRODUCT SPEC 108-2157	APPLICATION SPEC
MATERIAL ⑤		FINISH	SIZE 114-13112	RESTRICTED TO
Customer Drawing		WEIGHT	A100779C=1600788	SCALE 4:1 SHEET 1 OF 7 REV L7

LOC	DIST	REVISIONS			
P	LTN	DESCRIPTION	DATE	DMN	APVD
-	-	SEE SHEET 1	-	-	-

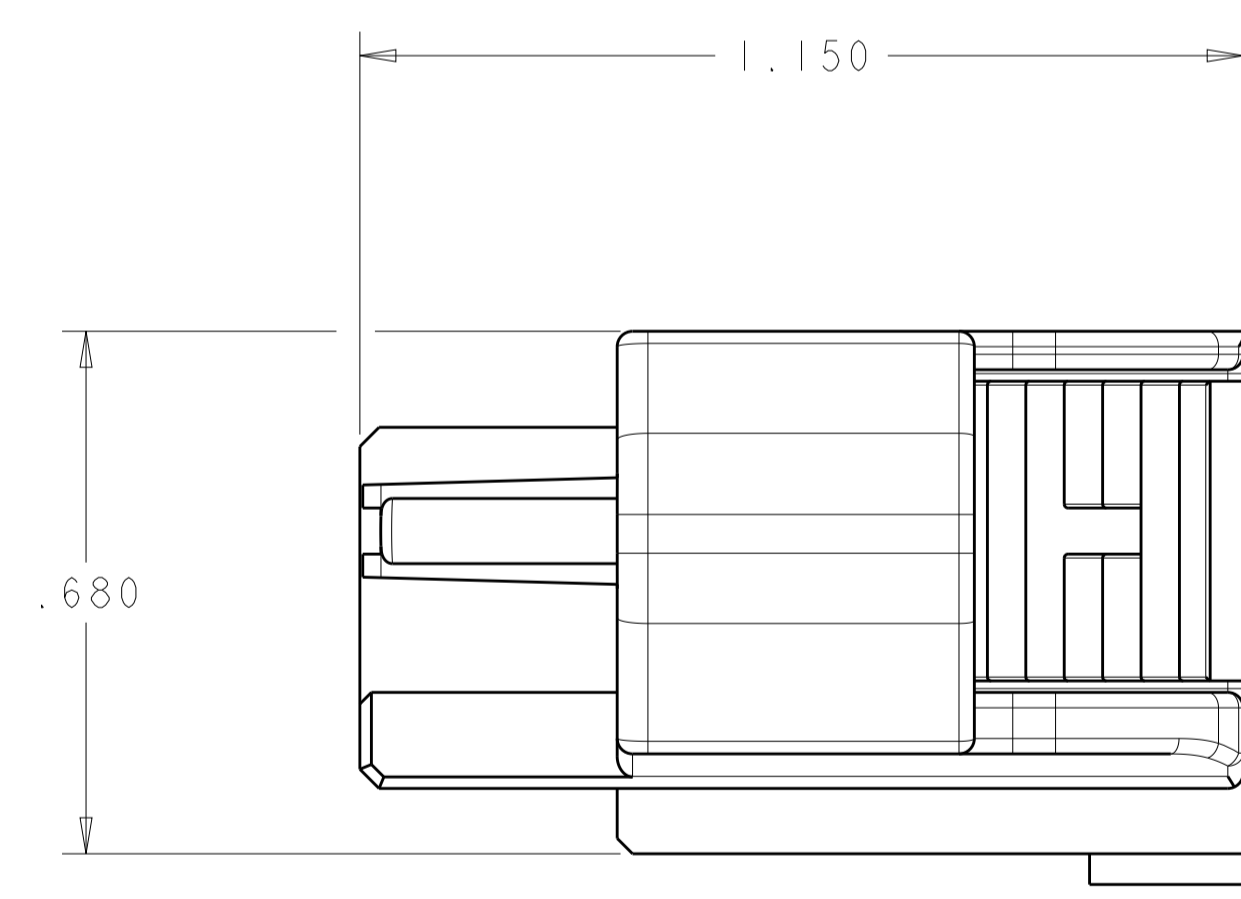
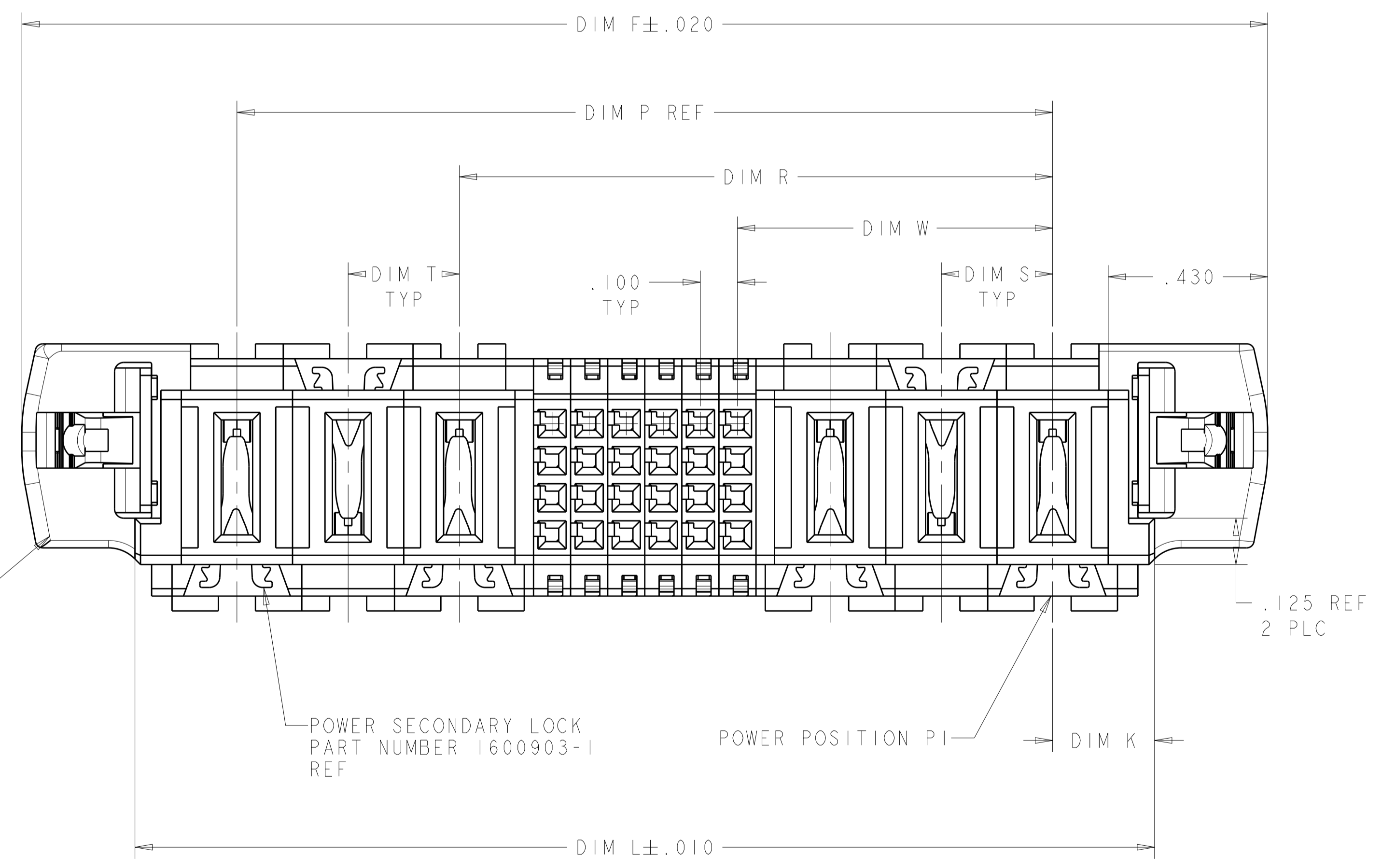
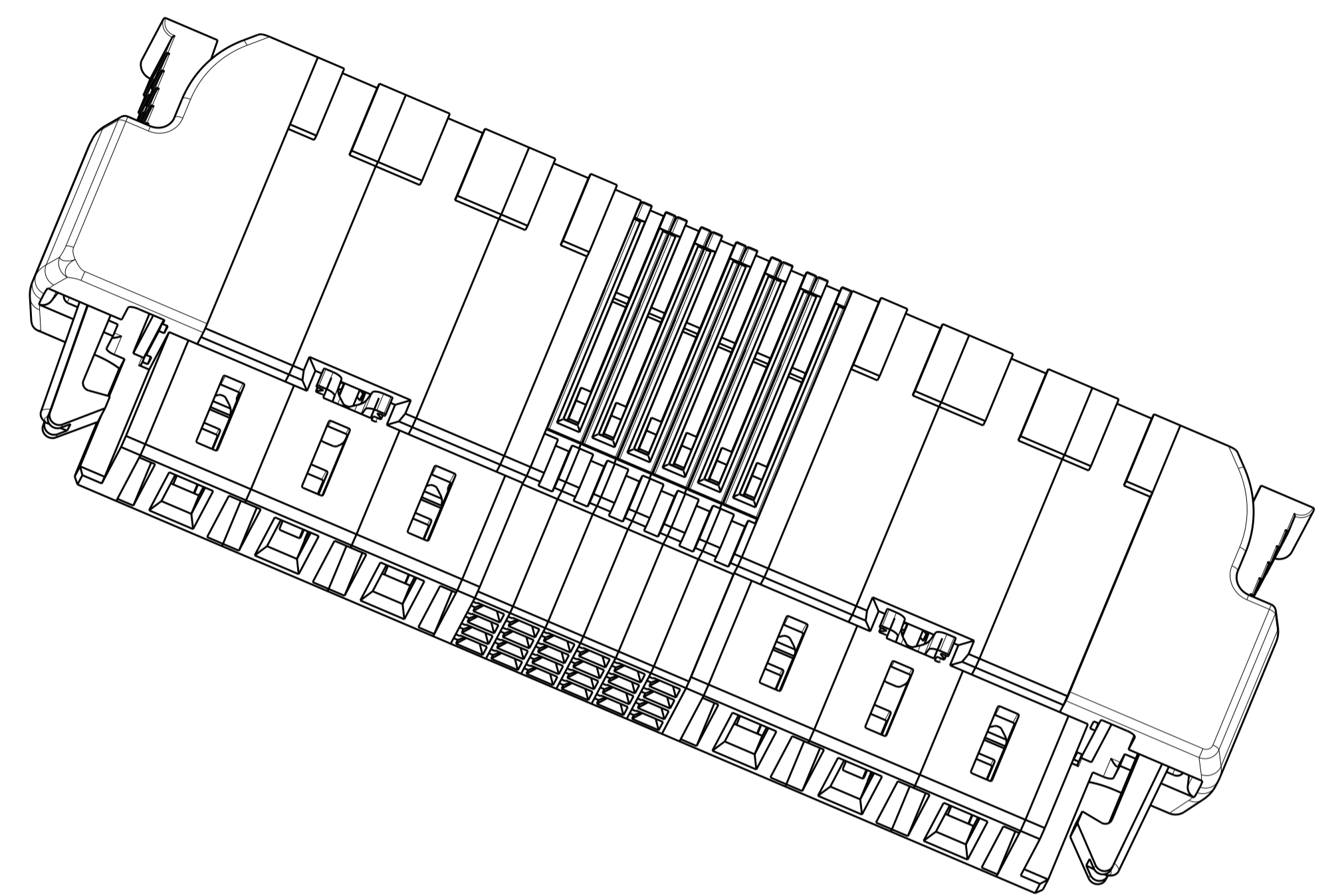
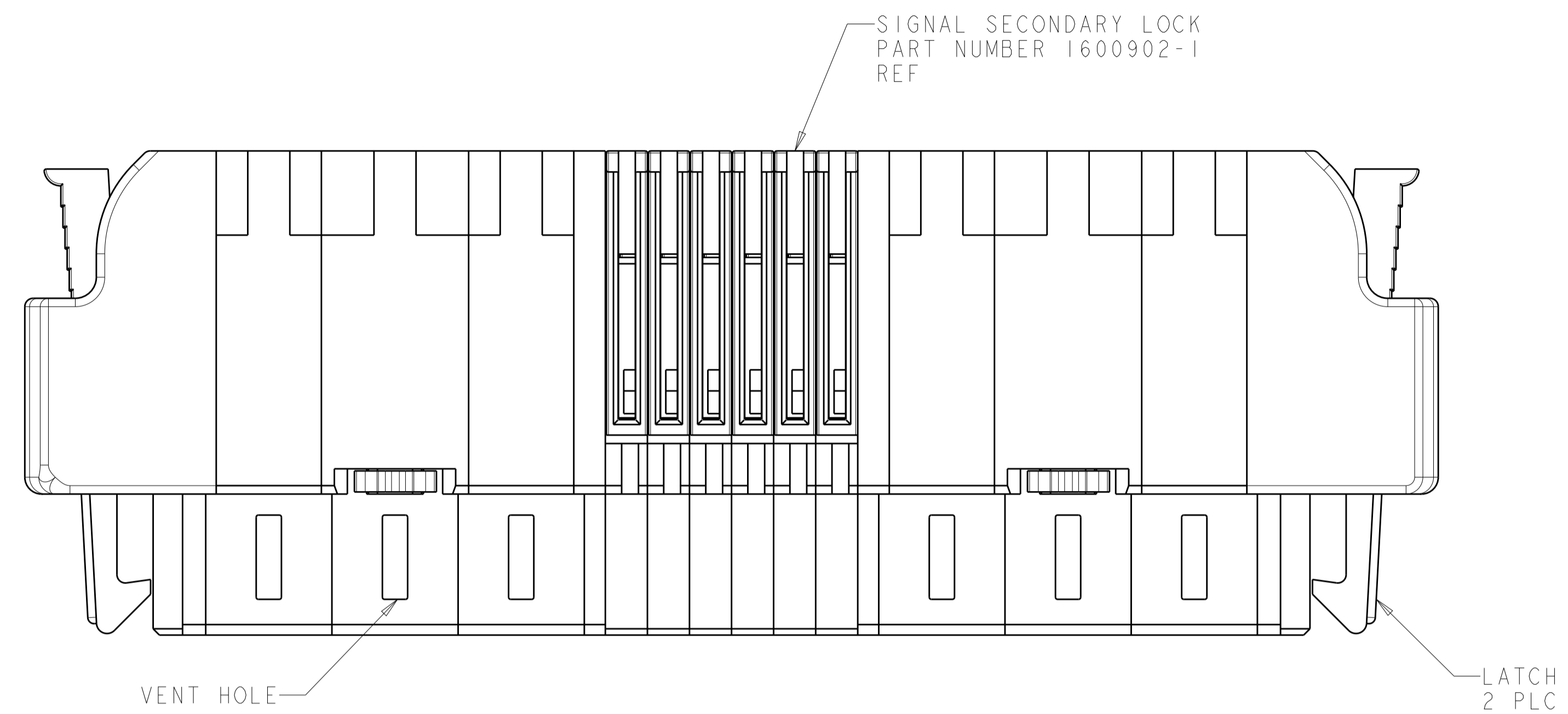

(K2) THE CONFIGURATION WITH VENT HOLES
PART NO.: 2-1600788-6

THIS DRAWING IS A CONTROLLED DOCUMENT.		DMN R. GRZYBOWSKI CHK P. DAMATO APVD P. DAMATO	TOMAY05 TOMAY05 TOMAY05	TE Connectivity NAME SQUEEZE TO RELEASE CABLE RECEPTACLE ASSEMBLY W/ LATCHES AND KEY, MULTI-BEAM XLE
DIMENSIONS: INCHES	TOLERANCES UNLESS OTHERWISE SPECIFIED:	PRODUCT SPEC 108-2157 APPLICATION SPEC 114-13112	SIZE CAGE CODE DRAWING NO A100779C=1600788	
MATERIAL	FINISH	WEIGHT	Customer Drawing	RESTRICTED TO
SCALE 4:1			SHEET 1 OF 6	REV L7

LOC		DIST		REVISIONS			
P	LTN	DESCRIPTION	DATE	DMN	APVD		
-	-	SEE SHEET 1	-	-	-	-	-

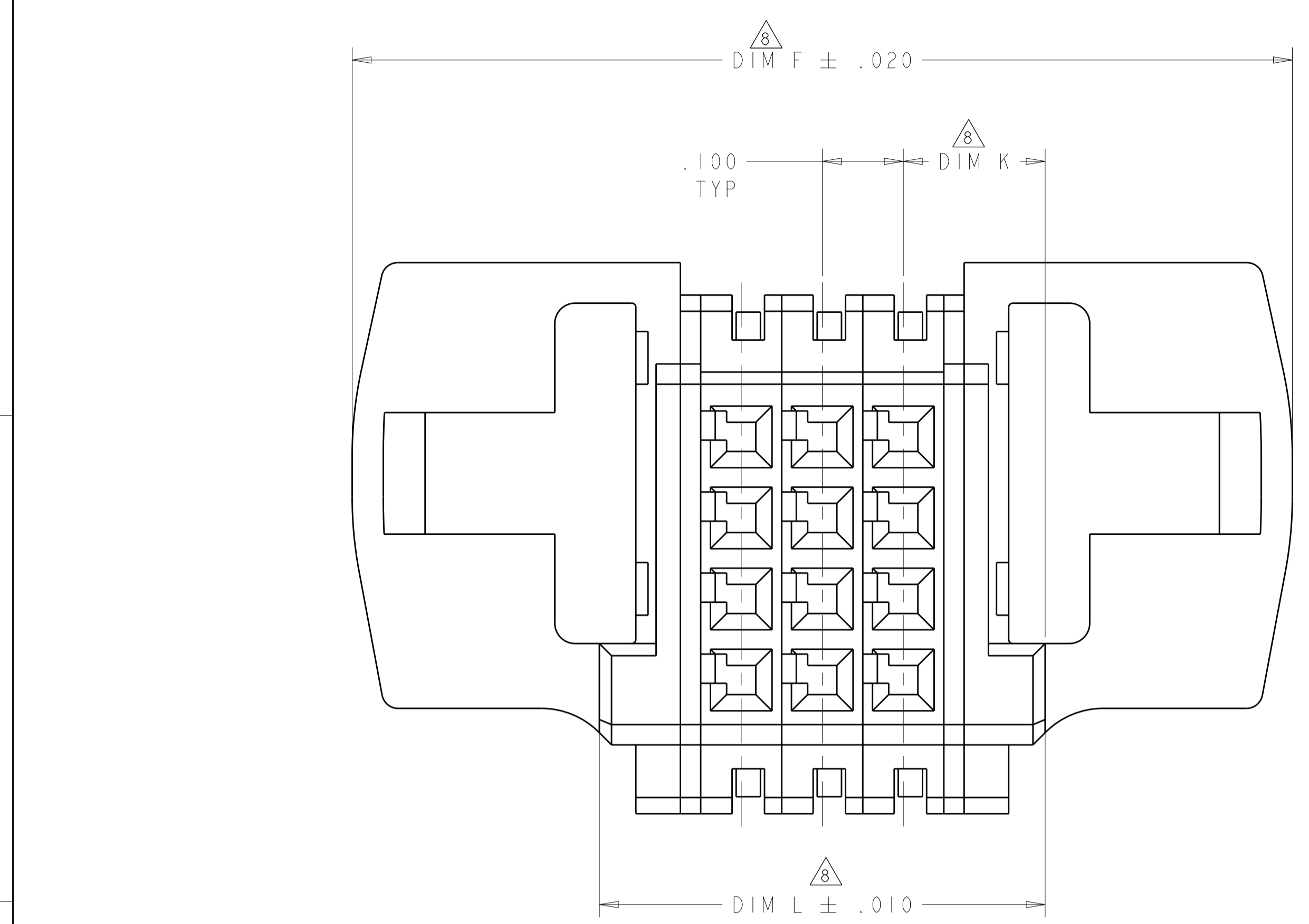

FOR CONFIGURATION "S"
 PART 2-1600788-7

CENTER MODULE	DIM P	DIM W	DIM T	DIM S	DIM R	DIM L	DIM K	DIM F	DESCRIPTION	PART NUMBER
NO	.950	.375	.200	.200	.950	1.600	.225	2.210	2P + 20S + 2P	4-1600788-1
NO	.850	.175	-	-	.850	1.300	.225	1.910	1P + 24S + 1P	4-1600788-0
NO	1.725	.850	.250	.300	1.475	2.200	.250	2.810	3ACP + 24S + 2P	3-1600788-9
NO	1.000	.400	.200	.200	.800	1.400	.200	2.010	2HDP + 12S + 2HDP	3-1600788-8
NO	1.200	.550	.300	.300	.900	1.750	.275	2.360	2ACP + 8S + 2ACP	3-1600788-7
NO	2.050	.475	.250	.250	1.800	2.500	.225	3.110	2P + 48S + 2P	3-1600788-6
NO	1.250	.475	.250	.250	1.000	1.700	.225	2.310	2P + 16S + 2P	3-1600788-5
NO	.500	.200	-	-	.500	.900	.200	1.510	1HDP + 8S + 1HDP	3-1600788-4
NO	.700	.200	-	-	.700	1.100	.200	1.710	1HDP + 16S + 1HDP	3-1600788-3
NO	-	-	-	-	-	1.325	.200	1.310	16S	3-1600788-1
NO	-	-	-	-	-	1.825	.175	2.435	64S	3-1600788-0
NO	-	-	-	-	-	1.200	.200	1.810	36S	2-1600788-9
NO	1.400	.250	.300	.300	1.400	1.950	.275	2.560	1P + 40S + 1P	2-1600788-8
NO	-	-	-	-	-	.550	.175	1.160	12S	2-1600788-7
NO	2.200	.850	.300	.300	1.600	2.750	.275	3.360	3ACP + 24S + 3ACP	2-1600788-6
NO	1.100	.500	.300	.300	.800	1.600	.250	2.210	2ACP + 8S + 2ACP	2-1600788-5
NO	.450	.225	-	-	.450	.900	.225	1.510	1P + 4S + 1P	2-1600788-4
NO	2.400	.850	.300	.300	1.800	2.950	.275	3.560	3ACP + 32S + 3ACP	2-1600788-3
NO	1.600	.550	.300	.300	1.300	2.150	.275	2.760	2ACP + 24S + 2ACP	2-1600788-0
NO	2.200	.850	.300	.300	1.600	2.750	.275	3.360	3ACP + 24S + 3ACP	1-1600788-9
NO	3.450	1.475	.250	.250	2.200	3.900	.225	4.510	6P + 24S + 6P	1-1600788-7
NO	-	-	-	-	-	2.000	.200	2.610	0P + 68S + 0P	1-1600788-6
NO	2.800	1.150	.300	.300	1.900	3.350	.275	3.960	4ACP + 24S + 4ACP	1-1600788-5
NO	2.450	.975	.250	.250	1.700	2.900	.225	3.510	4P + 24S + 4P	1-1600788-4
NO	1.050	.475	.250	.250	.800	1.500	.225	2.110	2P + 8S + 2P	1-1600788-3
NO	2.200	.850	.300	.300	1.600	2.750	.275	3.360	3ACP + 24S + 3ACP	1-1600788-2
NO	1.250	.475	.250	.250	1.000	1.700	.225	2.310	2P + 16S + 2P	1-1600788-0
NO	1.550	.725	.250	.250	1.050	2.000	.225	2.610	3P + 8S + 3P	1600788-9
NO	.950	.225	-	-	.950	1.400	.225	2.010	1P + 24S + 1P	1600788-8
NO	3.975	1.650	.250	.250	2.575	4.475	.225	5.085	6P + 32S + 6P	1600788-7
NO	2.750	1.475	.250	.250	2.500	3.200	.225	3.810	6P + 36S + 2P	1600788-4
NO	4.625	1.150	.250	.300	1.875	5.125	.275	5.735	4ACP + 24S + 12P	1600788-3
NO	2.650	.975	.250	.250	1.900	3.100	.225	3.710	4P + 32S + 4P	1600788-2
NO	1.450	.475	.250	.250	1.200	1.900	.225	2.510	2P + 24S + 2P	1600788-1

THIS DRAWING IS A CONTROLLED DOCUMENT. DMN: R. GRZYBOWSKI, TOMAYOS; CHK: P. DAMATO, TOMAYOS; APVD: P. DAMATO, TOMAYOS.

STE TE Connectivity

NAME: SQUEEZE TO RELEASE CABLE RECEPTACLE ASSEMBLY W/ LATCHES AND KEY, MULTI-BEAM XLE

PRODUCT SPEC: 108-2157
 APPLICATION SPEC: 114-13112

SIZE: A100779, CAGE CODE: 1600788, DRAWING NO: 1600788-7

Customer Drawing, SCALE: 4:1, SHEET 1 OF 6, REV: L7

LOC		DIST		REVISIONS			
P	LTN	DESCRIPTION	DATE	OWN	APVD		
-	-	SEE SHEET 1	-	-	-		

PART NUMBER	ROWS	POWER (L)		SIGNAL						POWER (R)			
		P4	P3	6	5	4	3	2	1	P2	P1		
1600788-1	D	RM	RM	E	E	E	E	E	E	E	E	RA	RA
	C			E	E	E	E	E	E	E			
	B			E	E	E	E	E	E	E			
	A			E	E	E	E	E	E	E			
2P + 24S + 2P													

PART NUMBER	ROWS	POWER (L)		SIGNAL						POWER (R)		
		P2	P1	6	5	4	3	2	1	P1		
1600788-8	D	RM	RM	E	E	E	E	E	E	E	RM	
	C			E	E	E	E	E	E			
	B			E	E	E	E	E	E			
	A			E	E	E	E	E	E			
1P + 24S + 1P												

PART NUMBER	ROWS	POWER (L)				SIGNAL								POWER (R)							
		P8	P7	P6	P5	8	7	6	5	4	3	2	1	P4	P3	P2	P1				
1600788-2	D	RM	RM	RM	RM	E	E	E	E	E	E	E	E	E	E	E	E	RM	RM	RM	RM
	C					E	E	E	E	E	E	E	E	E	E						
	B					E	E	E	E	E	E	E	E	E	E						
	A					E	E	E	E	E	E	E	E	E	E						
4P + 32S + 4P																					

PART NUMBER	ROWS	POWER (L)		SIGNAL				POWER (R)	
		P4	P3	4	3	2	1	P2	P1
1-1600788-0	D	RM	RM	E	E	E	E	RA	RA
	C			E	E	E	E		
	B			E	E	E	E		
	A			E	E	E	E		
2P + 16S + 2P									

PART NUMBER	ROWS	POWER (L)										SIGNAL						POWER (R)																											
		P16	P15	P14	P13	P12	P11	P10	P9	P8	P7	P6	P5	6	5	4	3	2	1	P4	P3	P2	P1																						
1600788-3	D	RA	RM	RA	RM	RA	RM	RA	RM	RA	RM	RA	RM	RA	RM	RA	RM	RA	RM	RA	RM	RA	RM																						
	C																							E	E	E	E	E	E	E	E	E	E	E	E	E	E	E	E	E	E	E	E	E	
	B																							E	E	E	E	E	E	E	E	E	E	E	E	E	E	E	E	E	E	E	E	E	E
	A																							E	E	E	E	E	E	E	E	E	E	E	E	E	E	E	E	E	E	E	E	E	E
4ACP + 24S + 12P																																													

PART NUMBER	ROWS	POWER (L)			SIGNAL						POWER (R)				
		P6	P5	P4	6	5	4	3	2	1	P3	P2	P1		
1-1600788-2	D	RM	RM	RM	E	E	E	E	E	E	E	E	RM	RM	RM
	C				E	E	E	E	E	E	E				
	B				E	E	E	E	E	E	E				
	A				E	E	E	E	E	E	E				
3ACP + 24S + 3ACP															

PART NUMBER	ROWS	POWER (L)		SIGNAL								POWER (R)							
		P8	P7	9	8	7	6	5	4	3	2	1	P6	P5	P4	P3	P2	P1	
1600788-4	D	RM	RM	E	E	E	E	E	E	E	E	E	E	RM	RM	RM	RM	RM	RM
	C			E	E	E	E	E	E	E	E	E							
	B			E	E	E	E	E	E	E	E	E							
	A			E	E	E	E	E	E	E	E	E							
6P + 36S + 2P																			

PART NUMBER	ROWS	POWER (L)		SIGNAL		POWER (R)	
		P4	P3	2	1	P2	P1
1-1600788-3	D	RM	RM	E	E	RA	RM
	C			E	E		
	B			E	E		
	A			E	E		
2P + 8S + 2P							

PART NUMBER	ROWS	POWER (L)				SIGNAL								POWER (R)																											
		P12	P11	P10	P9	P8	P7	8	7	6	5	4	3	2	1	P6	P5	P4	P3	P2	P1																				
1600788-7	D	RM	RM	RM	RM	RM	RM	RM	RM	RM	RM	RM	RM	RM	RM	RM	RM	RM	RM	RM	RM																				
	C																					E	E	E	E	E	E	E	E	E	E	E	E	E	E	E	E	E	E	E	
	B																					E	E	E	E	E	E	E	E	E	E	E	E	E	E	E	E	E	E	E	E
	A																					E	E	E	E	E	E	E	E	E	E	E	E	E	E	E	E	E	E	E	E
6P + 32S + 6P																																									

REFERENCE
WIRE CHART AND CONTACTS

HOUSING MODULE	CONTACT	INSULATION DIAMETER RANGE
.300 POWER	8 - 10 REF 1600960	[.176 - .272]
.250 POWER	8 - 10 REF 1600960	[.176 - .203]
	12 - 14 REF 1600961	[.156 - .176]
.200 POWER	12 - 14 REF 1600961	[.120 - .156]
.100 SIGNAL	22 - 26 REF 5531216-5	[.036 - .069]

POWER CONTACT, STD	RM
POWER CONTACT, MFBL	RA
SIGNAL CONTACT	E
DESCRIPTION	CODE
CODES	

THIS DRAWING IS A CONTROLLED DOCUMENT.

DIMENSIONS: INCHES	TOLERANCES UNLESS OTHERWISE SPECIFIED:	0 PLC ±.010	1 PLC ±.010	2 PLC ±.010	3 PLC ±.010	4 PLC ±.010	ANGLES ±.0020
--------------------	--	-------------	-------------	-------------	-------------	-------------	---------------

OWN: R. GRZYBOWSKI	TOMAYOS
CHK: P. DAMATO	TOMAYOS
APVD: P. DAMATO	TOMAYOS
PRODUCT SPEC	108-2157
APPLICATION SPEC	114-13112
WEIGHT	-

STE TE Connectivity

SQUEEZE TO RELEASE CABLE RECEPTACLE ASSEMBLY W/ LATCHES AND KEY, MULTI-BEAM XLE

SIZE: CAGE CODE DRAWING NO: A100779C=1600788

Customer Drawing SCALE: 4:1 SHEET 1 OF 6 REV: 7

PART NUMBER	ROWS	POWER (L)				SIGNAL						POWER (R)			
		P8	P7	P6	P5	6	5	4	3	2	1	P4	P3	P2	P1
I-1600788-4	D	RM	RM	RM	RM	E	E	E	E	E	E	RM	RM	RM	RM
	C					E	E	E	E	E	E				
	B					E	E	E	E	E	E				
	A					E	E	E	E	E	E				
4P + 24S + 4P															

PART NUMBER	ROWS	POWER (L)			SIGNAL		POWER (R)		
		P6	P5	P4	2	1	P3	P2	P1
1600788-9	D	RM	RM	RM	E	E	RM	RM	RM
	C				E	E			
	B				E	E			
	A				E	E			
3P + 8S + 3P									

PART NUMBER	ROWS	POWER (L)				SIGNAL						POWER (R)			
		P8	P7	P6	P5	6	5	4	3	2	1	P4	P3	P2	P1
I-1600788-5	D	RM	RM	RM	RM	E	E	E	E	E	E	RM	RM	RM	RM
	C					E	E	E	E	E	E				
	B					E	E	E	E	E	E				
	A					E	E	E	E	E	E				
4ACP + 24S + 4ACP															

PART NUMBER	ROWS	POWER			SIGNAL						POWER				
		P6	P5	P4	8	7	6	5	4	3	2	1	P3	P2	P1
2-1600788-3	D	RM	RM	RM	E	E	E	E	E	E	E	E	RM	RM	RM
	C				E	E	E	E	E	E	E				
	B				E	E	E	E	E	E	E				
	A				E	E	E	E	E	E	E				
3ACP+32S+3ACP															

PART NUMBER	ROWS	SIGNAL																
		17	16	15	14	13	12	11	10	9	8	7	6	5	4	3	2	1
I-1600788-6	D	E	E	E	E	E	E	E	E	E	E	E	E	E	E	E	E	E
	C																	
	B																	
	A																	
OP + 68S + OP																		

PART NUMBER	ROWS	P (L)		SIGNAL		P (R)	
		P2	P1	I	P1	P2	P1
2-1600788-4	D	RM	RM	E	E	RM	RM
	C			E	E		
	B			E	E		
	A			E	E		
IP + 4S + IP							

PART NUMBER	ROWS	POWER (L)		SIGNAL		POWER (R)	
		P4	P3	2	1	P2	P1
2-1600788-5	D	RA	RA	E	E	RA	RA
	C			E	E		
	B			E	E		
	A			E	E		
2ACP + 8S + 2ACP							

PART NUMBER	ROWS	POWER (L)					SIGNAL						POWER (R)						
		P12	P11	P10	P9	P8	P7	6	5	4	3	2	1	P6	P5	P4	P3	P2	P1
I-1600788-7	D	RM	RM	RM	RM	RM	E	E	E	E	E	E	RM	RM	RM	RM	RM	RM	
	C						E	E	E	E	E	E							
	B						E	E	E	E	E	E							
	A						E	E	E	E	E	E							
6P + 24S + 6P																			

PART NUMBER	ROWS	POWER (L)			SIGNAL						POWER (R)			
		P6	P5	P4	6	5	4	3	2	1	P3	P2	P1	
2-1600788-6	D	RA	RM	RM	E	E	E	E	E	E	E	RM	RA	RA
	C				E	E	E	E	E	E				
	B				E	E	E	E	E	E				
	A				E	E	E	E	E	E				
3ACP + 24S + 3ACP														

PART NUMBER	ROWS	POWER (L)			SIGNAL						POWER (R)		
		P6	P5	P4	6	5	4	3	2	1	P3	P2	P1
I-1600788-9	D	RM	RM	RM	E	E	E	E	E	E	RM	RM	RM
	C				E	E	E	E	E				
	B				E	E	E	E	E				
	A				E	E	E	E	E				
3ACP + 24S + 3ACP													

PART NUMBER	ROWS	SIGNAL		
		3	2	1
2-1600788-7	D	E	E	E
	C	E	E	E
	B	E	E	E
	A	E	E	E
12S				

PART NUMBER	ROWS	SIGNAL							
		9	8	7	6	5	4	3	2
2-1600788-9	D	E	E	E	E	E	E	E	E
	C	E	E	E	E	E	E	E	E
	B	E	E	E	E	E	E	E	E
	A	E	E	E	E	E	E	E	E
OP + 36S + OP									

PART NUMBER	ROWS	POWER		SIGNAL						POWER	
		P4	P3	6	5	4	3	2	1	P2	P1
2-1600788-0	D	RM	RM	E	E	E	E	E	E	RM	RM
	C			E	E	E	E	E			
	B			E	E	E	E	E			
	A			E	E	E	E	E			
2ACP+24S+2ACP											

PART NUMBER	ROWS	SIGNAL															
		16	15	14	13	12	11	10	9	8	7	6	5	4	3	2	1
3-1600788-0	D	E	E	E	E	E	E	E	E	E	E	E	E	E	E	E	
	C	E	E	E	E	E	E	E	E	E	E	E	E	E	E	E	
	B	E	E	E	E	E	E	E	E	E	E	E	E	E	E	E	
	A	E	E	E	E	E	E	E	E	E	E	E	E	E	E	E	
64S																	

THIS DRAWING IS A CONTROLLED DOCUMENT. DWN: R. GRZYBOWSKI, TOMAYOS; CHK: P. DAMATO, TOMAYOS; APVD: P. DAMATO, TOMAYOS

TE Connectivity

NAME: SQUEEZE TO RELEASE CABLE RECEPTACLE ASSEMBLY W/ LATCHES AND KEY, MULTI-BEAM XLE

PRODUCT SPEC: 108-2157
 APPLICATION SPEC: 114-13112

SIZE: A1 | CAGE CODE: 1600788 | DRAWING NO: 1600788

Customer Drawing | SCALE: 4:1 | SHEET: 1 of 6 | REV: L7

LOC		DIST		REVISIONS			
P	LTN	DESCRIPTION	DATE	DWN	APVD		
-	-	SEE SHEET 1	-	-	-		

PART NUMBER	ROWS	SIGNAL			
		4	3	2	1
3-1600788-1	D	E	E	E	E
	C	E	E	E	E
	B	E	E	E	E
	A	E	E	E	E
0P + 16S + 0P					

PART NUMBER	ROWS	POWER (L)		SIGNAL				POWER (R)	
		P4	P3	4	3	2	1	P2	P1
3-1600788-5	D	RM	RA	E	E	E	E	RA	RM
	C			E	E	E	E		
2P + 16S + 2P									

NO CONTACTS LOADED FOR ROW B AND D

PART NUMBER	ROWS	PL	SIGNAL										PR			
			P2	10	9	8	7	6	5	4	3	2		1	P1	
2-1600788-8	D	RM	E	E	E	E	E	E	E	E	E	E	E	E	E	RM
	C		E	E	E	E	E	E	E	E	E	E	E	E		
	B		E	E	E	E	E	E	E	E	E	E	E	E		
	A		E	E	E	E	E	E	E	E	E	E	E	E		
2P+40S+1P																

PART NUMBER	ROWS	POWER		SIGNAL												POWER			
		P4	P3	12	11	10	9	8	7	6	5	4	3	2	1	P2	P1		
3-1600788-6	D	RM	RM	E	E	E	E	E	E	E	E	E	E	E	E	E	E	RM	RM
	C			E	E	E	E	E	E	E	E	E	E	E	E	E			
	B			E	E	E	E	E	E	E	E	E	E	E	E	E			
	A			E	E	E	E	E	E	E	E	E	E	E	E	E			
2P+24S+2P																			

PART NUMBER	ROWS	P(L)	SIGNAL				P(R)
			P2	4	3	2	
3-1600788-3	D	RA	E	E	E	E	RM
	C		E	E	E	E	
	B		E	E	E	E	
	A		E	E	E	E	
1HDP + 16S + 1HDP							

PART NUMBER	ROWS	POWER (L)		SIGNAL		POWER (R)	
		P4	P3	2	1	P2	P1
3-1600788-7	D	RM	RM	E	E	RM	RM
	C			E	E		
	B			E	E		
	A			E	E		
2ACP + 8S + 2ACP							

PART NUMBER	ROWS	PL	SIGNAL						PR
			P2	6	5	4	3	2	
4-1600788-0	D	RM	E	E	E	E	E	E	RM
	C		E	E	E	E	E	E	
	B		E	E	E	E	E	E	
	A		E	E	E	E	E	E	
1P + 24S + 1P									

PART NUMBER	ROWS	PL	SIGNAL		PR
			P2	2	
3-1600788-4	D	RM	E	E	RM
	C		E	E	
	B		E	E	
	A		E	E	
1P + 8S + 1P					

PART NUMBER	ROWS	PL	SIGNAL			PR		
			P4	P3	3	2	1	P2
3-1600788-8	D	RM	RM	E	E	E	RM	RM
	C			E	E	E		
	B			E	E	E		
	A			E	E	E		
2HDP + 12S + 2HDP								

PART NUMBER	ROWS	PL	SIGNAL							PR			
			P5	P4	6	5	4	3	2	1	P3	P2	P1
3-1600788-9	D	RA	RA	E	E	E	E	E	E	E	RA	RA	RA
	C			E	E	E	E	E	E				
	B			E	E	E	E	E	E				
	A			E	E	E	E	E	E				
3ACP + 24S + 2P													

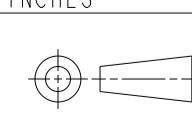
THIS DRAWING IS A CONTROLLED DOCUMENT.		DWN R. GRZYBOWSKI CHK P. DAMATO	TOMAY05		TE Connectivity	
DIMENSIONS: INCHES	TOLERANCES UNLESS OTHERWISE SPECIFIED:	APVD P. DAMATO	TOMAY05		NAME SQUEEZE TO RELEASE CABLE RECEPTACLE ASSEMBLY W/ LATCHES AND KEY, MULTI-BEAM XLE	
	0 PLC ±. 1 PLC ±0.01 2 PLC ±0.01 3 PLC ±0.005 4 PLC ±0.002 ANGLES ±0.002	PRODUCT SPEC 108-2157 APPLICATION SPEC 114-13112	SIZE A100779	DRAWING NO C=1600788		
MATERIAL	FINISH	WEIGHT	Customer Drawing	SCALE 4:1	SHEET 1 OF 6	REV L7

THIS DRAWING IS UNPUBLISHED. RELEASED FOR PUBLICATION 20
 © COPYRIGHT 20 BY - ALL RIGHTS RESERVED.

LOC		DIST		REVISIONS			
P	LTN	DESCRIPTION	DATE	DWN	APVD		
-		SEE SHEET 1	-	-	-		

PART NUMBER	ROWS	POWER		SIGNAL					POWER	
		P4	P3	5	4	3	2	1	P2	P1
4-1600788-1	D			E	E	E	E	E		
	C	RA	RA	E	E	E	E	E	RA	RA
	B			E	E	E	E	E		
	A			E	E	E	E	E		
2P+20S+2P										

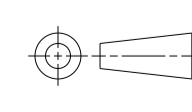
THIS DRAWING IS A CONTROLLED DOCUMENT.		DWN R. GRZYBOWSKI 10MAY05	 TE Connectivity
DIMENSIONS: INCHES		CHK P. DAMATO 10MAY05	
TOLERANCES UNLESS OTHERWISE SPECIFIED: 0 PLC ± 1 PLC ± 2 PLC ±0.01 3 PLC ±0.005 4 PLC ±0.0020 ANGLES ±7°		APVD P. DAMATO 10MAY05	NAME SQUEEZE TO RELEASE CABLE RECEPTACLE ASSEMBLY W/ LATCHES AND KEY, MULTI-BEAM XLE
		PRODUCT SPEC 108-2157	RESTRICTED TO
MATERIAL		APPLICATION SPEC 114-13112	SIZE A100779
FINISH		WEIGHT	DRAWING NO C=1600788
		Customer Drawing	SCALE 4:1 SHEET 1 OF 6 REV L7

Mouser Electronics

Authorized Distributor

Click to View Pricing, Inventory, Delivery & Lifecycle Information:

[TE Connectivity:](#)

[1-1600788-4](#)