

Photoelectrics Through-beam Type PA18C.T..., DC

CARLO GAVAZZI

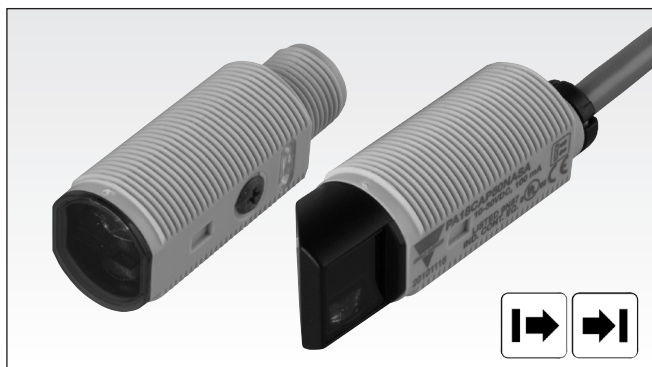

- Miniature sensor range
- Range: 20 m (Axial), 16 m (Radial)
- Sensitivity adjustment by potentiometer
- Modulated, infrared light 850 nm
- Supply voltage: 10 to 30 VDC
- Output: 100 mA, NPN or PNP, N.O + N.C.
- Degree of protection IP67, IP69K
- LED indication for output, stability and power ON
- Protection: reverse polarity, short circuit and transients
- Cable and plug versions
- Excellent EMC performance



Product Description

The PA18C.T... is part of a family of inexpensive general purpose through-beam sensors in industrial standard 18 mm cylindrical ABS housing. The sensors are useful in applications where high-accuracy detection as well as small size is required.

Compact housing and high power LED for excellent performance-size ratio. The potentiometer used for adjustment of the sensitivity makes the sensors highly flexible. The output type is NPN or PNP and the output switching function is NO and NC.

Ordering Key

PA18CAT20PAM1SA

Type	_____
Housing style	_____
Housing size	_____
Housing material	_____
Housing type axial	_____
Detection principle	_____
Sensing distance	_____
Output type	_____
Output configuration	_____
Connection type	_____
Sensitive adjustment	_____

Type Selection

Housing type	Range S _n	Connec- tion	Ordering no. Emitter	Ordering no. Receiver NPN Make or break switching	Ordering no. Receiver PNP Make or break switching
M18 Axial type	20 m	Cable	PA 18 CAT 20	PA 18 CAT 20 NASA	PA 18 CAT 20 PASA
M18 Axial type	20 m	Plug	PA 18 CAT 20M1	PA 18 CAT 20 NAM1SA	PA 18 CAT 20 PAM1SA
M18 Radial type	16 m	Cable	PA 18 CRT 16	PA 18 CRT 16 NASA	PA 18 CRT 16 PASA
M18 Radial type	16 m	Plug	PA 18 CRT 16M1	PA 18 CRT 16 NAM1SA	PA 18 CRT 16 PAM1SA

Specifications Receiver according to EN60947-5-2

Rated operating distance (S_n) Axial type (A) Radial type (R)	Up to 20 m, Up to 16 m	Minimum operational current (I_m)	0.5 mA
Blind zone	0 mm	OFF-state current (I_r)	≤ 100 μA
Sensitivity control Electrical adjustment Mechanical adjustment Adjustable distance to target Axial types Radial types	Adjustable by potentiometer 210° 240° 1 - 20 m 1 - 16 m	Voltage drop (U_d)	≤ 2.0 VDC @ 100 mA
Temperature drift	≤ 0.2%/°C	Protection	Short-circuit, reverse polarity and transients
Hysteresis (H) (differential travel)	≤ 20%	Sensing angle Axial Radial	± 4° ± 3°
Rated operational volt. (U_B)	10 to 30 VDC (ripple included)	Ambient light	30.000 lux Incandescent lamp
Ripple (U_{rpp})	≤ 10%	Operating frequency	500 Hz
Output current Continuous (I _a) Short-time (I)	≤ 100 mA ≤ 100 mA (max. load capacity 100 nF)	Response time OFF-ON (t _{ON}) ON-OFF (t _{OFF})	≤ 1.0 ms ≤ 1.0 ms
No load supply current (I_o)	≤ 15 mA @ 24 VDC	Power ON delay (t_v)	≤ 200 ms
		Output function Type Switching function	NPN or PNP NO and NC
		Indication Output ON Signal stability and power ON	LED, yellow LED, green



Specifications Emitter according to EN60947-5-2

Rated operational volt. (U_B)	10 to 30 VDC (ripple included)	Light spot Diameter	Ø 1500 mm @ 10 m
Ripple (U_{ripple})	≤ 10%	Protection	Reverse polarity and transients
Supply current (I_o)	≤ 25 mA	Indication function	LED, green LED, green
Light source	LED, 850 nm	Power on delay	< 200 ms
Light type	Infrared, modulated		
Sensing angle			
Axial	± 4°		
Radial	± 3°		

Specifications Common according to EN60947-5-2

Environment		Housing material	
Installation category	III (IEC 60664/60664A; 60947-1)	Body	ABS, grey
Pollution degree	3 (IEC 60664/60664A; 60947-1)	Front material	PMMA, red
Degree of protection	IP 67, IP 69K*	Cable gland	POM, Black
Ambient temperature		Trimmer shaft	POM, Dark Grey
Operating	-25° to +60°C (-13° to +140°F)	Locknuts	PBTB, black
Storage	-40° to +70°C (-40° to +158°F)	Mounting bracket	PPA, black
Vibration	10 to 150 Hz, 1 mm/15 G (IEC 60068-2-6)	Connection	
Shock	30 g / 11ms, 3 pos, 3 neg per axis (IEC 60068-2-6, 60068-2-32)	Cable	PVC, grey, 2 m
Rated insulation voltage	500 VAC (rms) IEC protection class III	Receiver	4 x 0.25 mm ² , Ø = 4.5 mm
		Emitter	2 x 0.25 mm ² , Ø = 4.5 mm
		Plug	M12, 4-pin (CONM14NF-series)
		Weight	With cable: 85 g With plug: 25 g
		CE-marking	Yes
		Approvals	cULus (UL508) supply class 2

* The IP69K test according to DIN 40050-9 for high-pressure, high-temperature wash-down applications. The sensor must not only be dust tight (IP6X), but also able to withstand high-pressure and steam cleaning. The sensor is exposed to high pressure water from a spray nozzle that is fed with 80°C water at 8'000–10'000 KPa (80–100bar) and a flow rate of 14–6L/min. The nozzle is held 100–150 mm from the sensor at angles of 0°, 30°, 60° and 90° for 30s each. The test device sits on a turntable that rotates with a speed of 5 times per minute. The sensor must not suffer any damaging effects from the high pressure water in appearance and function.

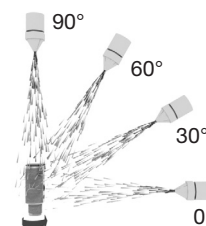

Operation Diagram

tv = Power ON delay

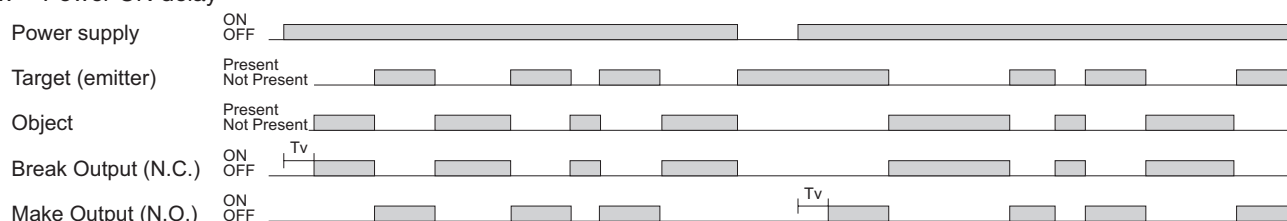

Wiring Diagrams

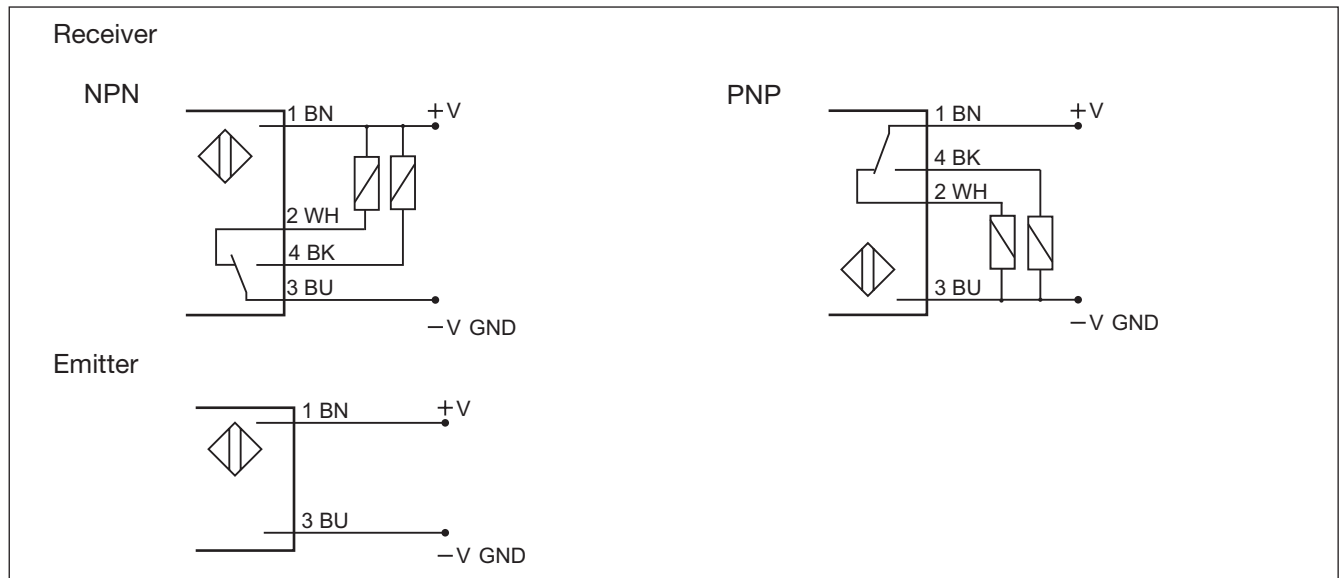

Detection Diagram

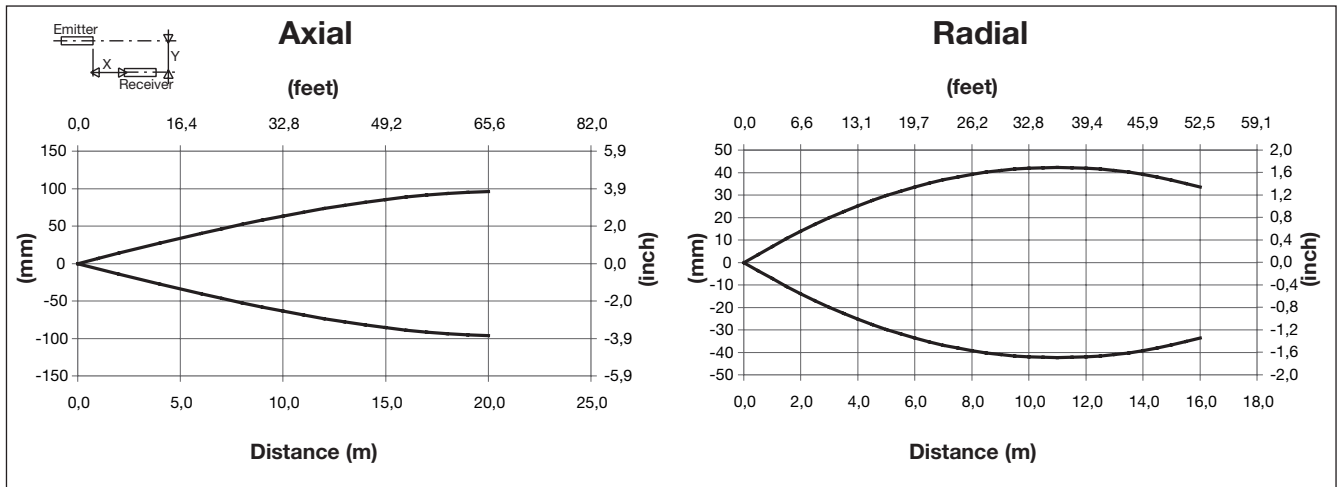

Excess Gain

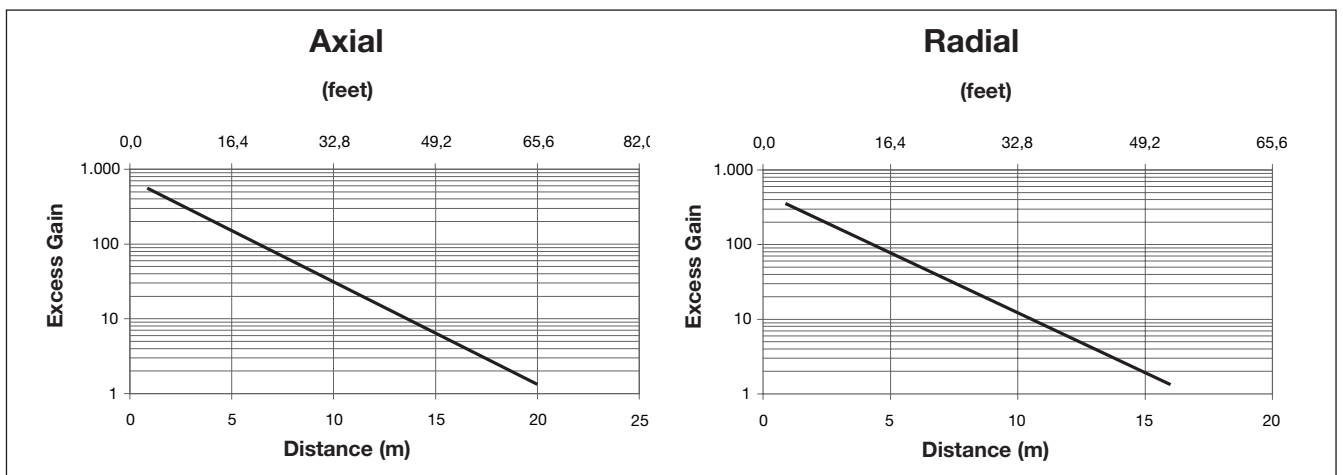

Dimensions Radial version

Cable version

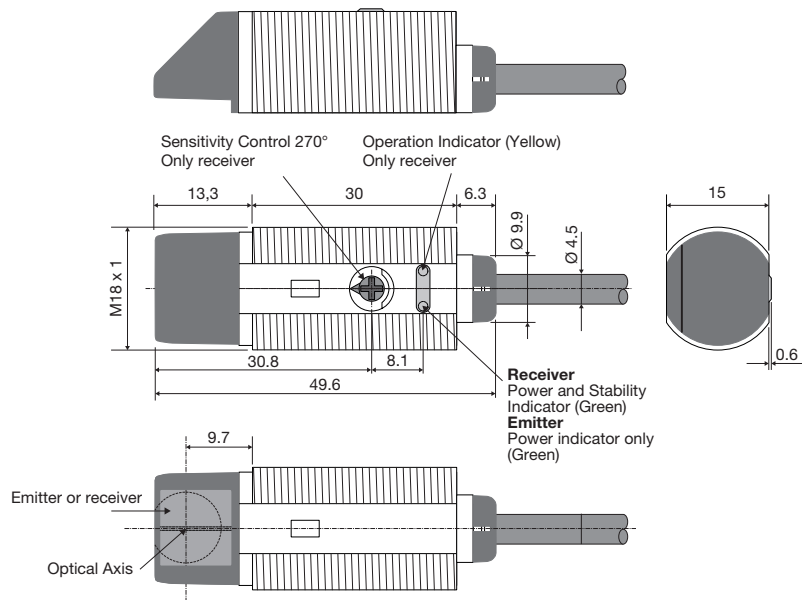

Plug version

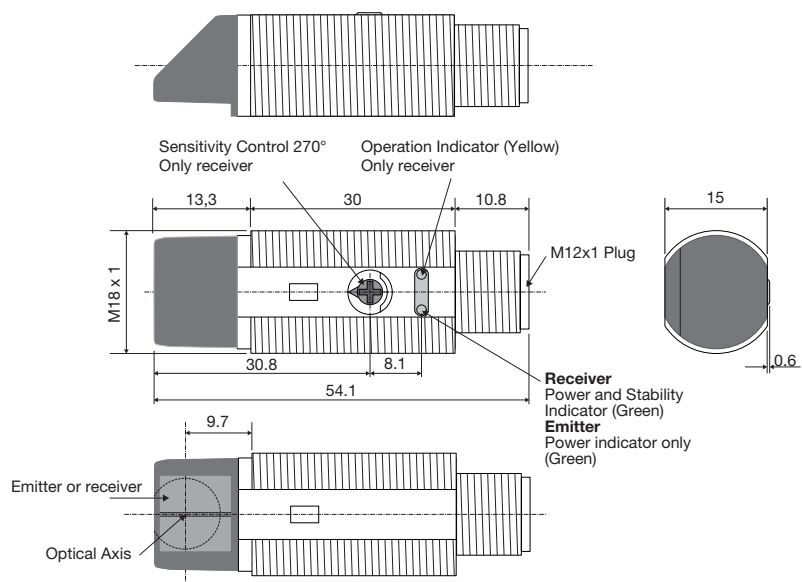

Dimensions Axial version

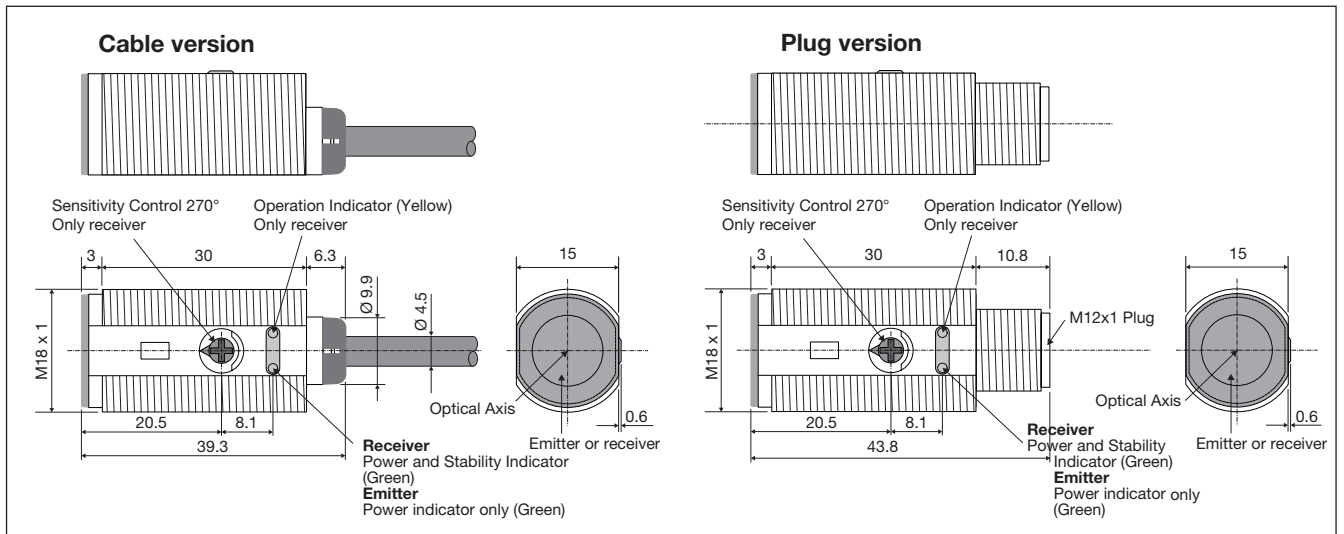

Signal Stability Indication

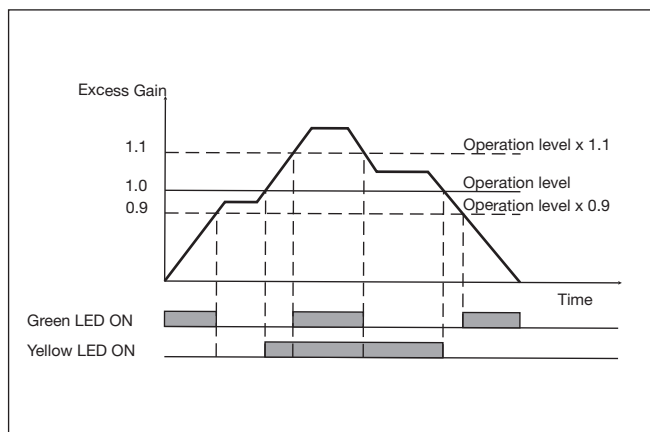

APA18-MB1

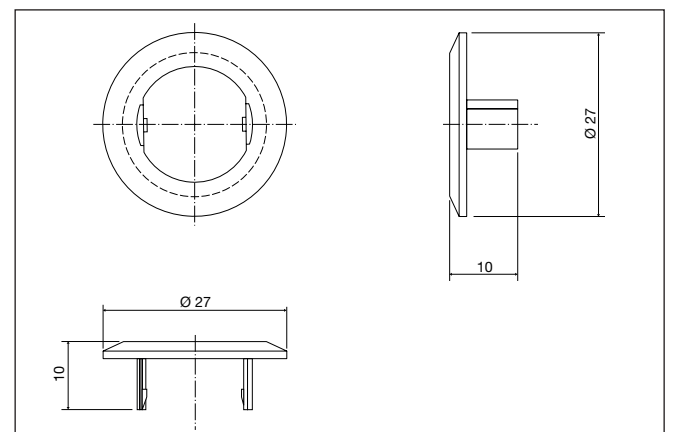

Mounting Systems

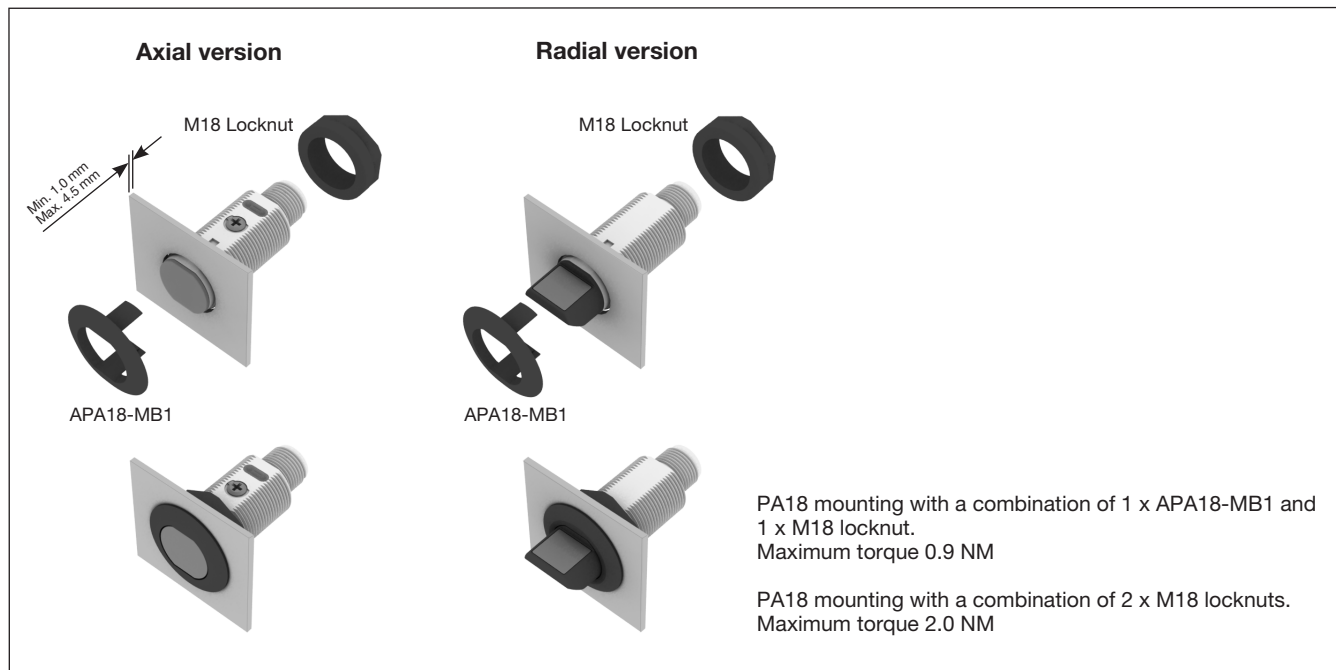

Installation Hints

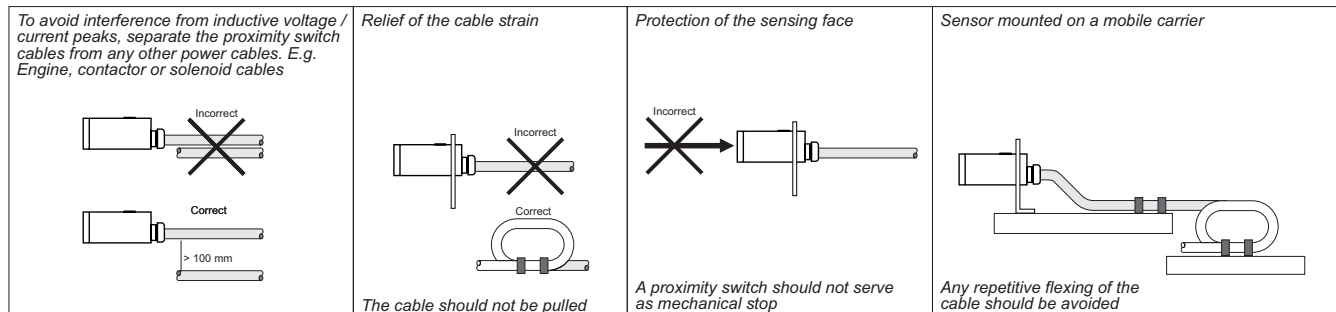

Delivery Contents

- Photoelectric switch: PA 18 C.T...
- Installation instruction on plastic bag
- Screwdriver
- Mounting bracket APA18-MB1
- 2 M18 locknuts
- **Packaging:** Plastic bag
- Emitter and receiver is packed separately

Accessories

- Connector type CONG1A.. / CONM14NF.. series

Mouser Electronics

Authorized Distributor

Click to View Pricing, Inventory, Delivery & Lifecycle Information:

[Carlo Gavazzi:](#)

[PA18CRT16M1](#) [PA18CRT16NASA](#) [PA18CRT16NAM1SA](#) [PA18CRT16PAM1SA](#) [PA18CAT20](#) [PA18CRT16](#)
[PA18CRT16PASA](#) [PA18CAT20M1](#) [PA18CAT20NASA](#) [PA18CAT20PAM1SA](#) [PA18CAT20PASA](#)
[PA18CAT20NAM1SA](#)