



RVT70HSBNWC00-B

EVE4 IPS 7.0" LCD TFT DATASHEET

Rev.1.4

2021-12-06

ITEM	CONTENTS	UNIT
LCD Type	TFT/Transmissive/Normally Black/IPS	/
Size	7.0	Inch
Viewing Direction	Free	/
Outside Dimensions (W x H x D)	179.96 x 119.00 x 13.08	mm
Active Area (W x H)	154.21 x 85.92	mm
Pixel Pitch (W x H)	0.1506 x 0.1432	mm
Resolution	1024 (RGB) x 600	/
Brightness	850	cd/m ²
Color Depth	16.7 M	/
Pixel Arrangement	RGB Vertical Stripe	/
Driver IC of Board	BT817Q	/
Rectangular pixel correction	Yes	/
Interface	SPI/QSPI	/
Host Connector	RiBUS, ZIF 20 pin, 0.5mm pitch, down-side contact	/
With/Without Touch	With Projected Capacitive Touch Panel	/
CTP Driver	ILI2132A	/
Supply Voltage for Module	3.3	V
Supply Voltage for Backlight	5.0 (TYP.)	V
Bonding Technology	Optical Bonding	/
Weight	228	g

Note 1: RoHS3 compliant

Note 2: LCM weight tolerance: $\pm 5\%$.



1. REVISION RECORD

REV NO.	REV DATE	CONTENTS	REMARKS
1.0	2021-04-19	Initial Release	
1.1	2021-06-03	Updating the drawing	
1.2	2021-07-20	Updating the supply voltage for backlight	
1.3	2021-07-30	Updating the drawing (dimensions in inches, adding the speaker), New template	
1.4	2021-12-06	Add the accessory link of Riverdi louder speaker: RVA-SPK1.5W-C150, which is matched with Riverdi's all EVE4 series displays.	



2. CONTENTS

- 1. REVISION RECORD..... 2
- 2. CONTENTS..... 3
- 3. MODULE CLASSIFICATION INFORMATION..... 4
- 4. ASSEMBLY GUIDE..... 5
 - 4.1 uxTouch ASSEMBLY..... 5
- 5. MODULE DRAWING..... 6
- 6. ABSOLUTE MAXIMUM RATINGS..... 7
- 7. ELECTRICAL CHARACTERISTICS 7
- 8. BACKLIGHT ELECTRICAL CHARACTERISTICS..... 7
- 9. ELECTRO-OPTICAL CHARACTERISTICS..... 8
- 10. INTERFACES DESCRIPTION..... 10
 - 10.1 P1 connector - RiBUS description..... 10
 - 10.2 P2 connector description..... 10
- 11. BT817Q CONTROLLER SPECIFICATION..... 11
 - 11.1 Serial host interface..... 11
 - 11.2 Block Diagram 12
 - 11.3 Host interface SPI mode 0..... 12
 - 11.4 Backlight driver block diagram..... 13
- 12. TFT LCD TIMING CHARACTERISTICS..... 14
 - 12.1 Horizontal input timing..... 14
 - 12.2 Vertical input timing..... 14
 - 12.3 Parallel RGB timing characteristics..... 15
 - 12.3.1 DE MODE 15
 - 12.3.2 HV MODE - Horizontal input timing..... 15
 - 12.3.3 HV MODE - Vertical input timing 15
- 13. CAPACITIVE TOUCH SCREEN PANEL SPECIFICATIONS..... 16
 - 13.1 Mechanical characteristics..... 16
 - 13.2 Electrical characteristics..... 16
- 14. MODULE INITIALIZATION..... 17
- 15. INSPECTION 18
 - 15.1 Inspection condition 18
 - 15.2 Inspection standard..... 19
- 16. RELIABILITY TEST..... 20
- 17. LEGAL INFORMATION 21



3. MODULE CLASSIFICATION INFORMATION

RV	T	70	H	S	B	N	W	C	00	B
1.	2.	3.	4.	5.	6.	7.	8.	9.	10.	11.

NO.	PARAMETER	SYMBOL
1.	BRAND	RV – Riverdi
2.	PRODUCT TYPE	T – TFT Standard
3.	DISPLAY SIZE	70 – 7.0"
4.	MODEL SERIAL NO.	H – High Brightness, IPS
5.	RESOLUTION	S – 1024 x 600 px
6.	INTERFACE	B – SPI/QSPI
7.	FRAME	N – Without Mounting Metal Frame
8.	BACKLIGHT TYPE	W – LED White
9.	TOUCH PANEL	C – With Capacitive Touch Panel
10.	VERSION	00 – (00-99)
11.	BONDING TECHNOLOGY	B – Optical bonding

4. ASSEMBLY GUIDE

4.1 uxTouch ASSEMBLY

uxTouch are LCD TFT displays with specially designed projected capacitive touch panels. uxTouch display can be mounted without any additional holes in the housing. Our standard uxTouch displays include double-sided adhesive tape (DST) to stick TFT easily to the housing.

uxTouch models with double-side adhesive tape can be mounted by fastening the glass to the housing.

Figure 1. General view of the module

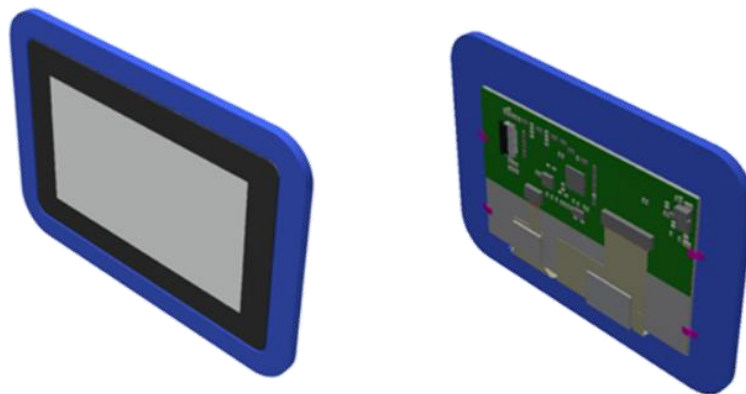

Revision:	Changes:	Date:
1.0	Initial Case	2020.12.09
1.1	PCB Update And Dimension Overhaul	2021.04.12
1.2	Adding Speaker PN And Matching Connector PN	2021.07.09

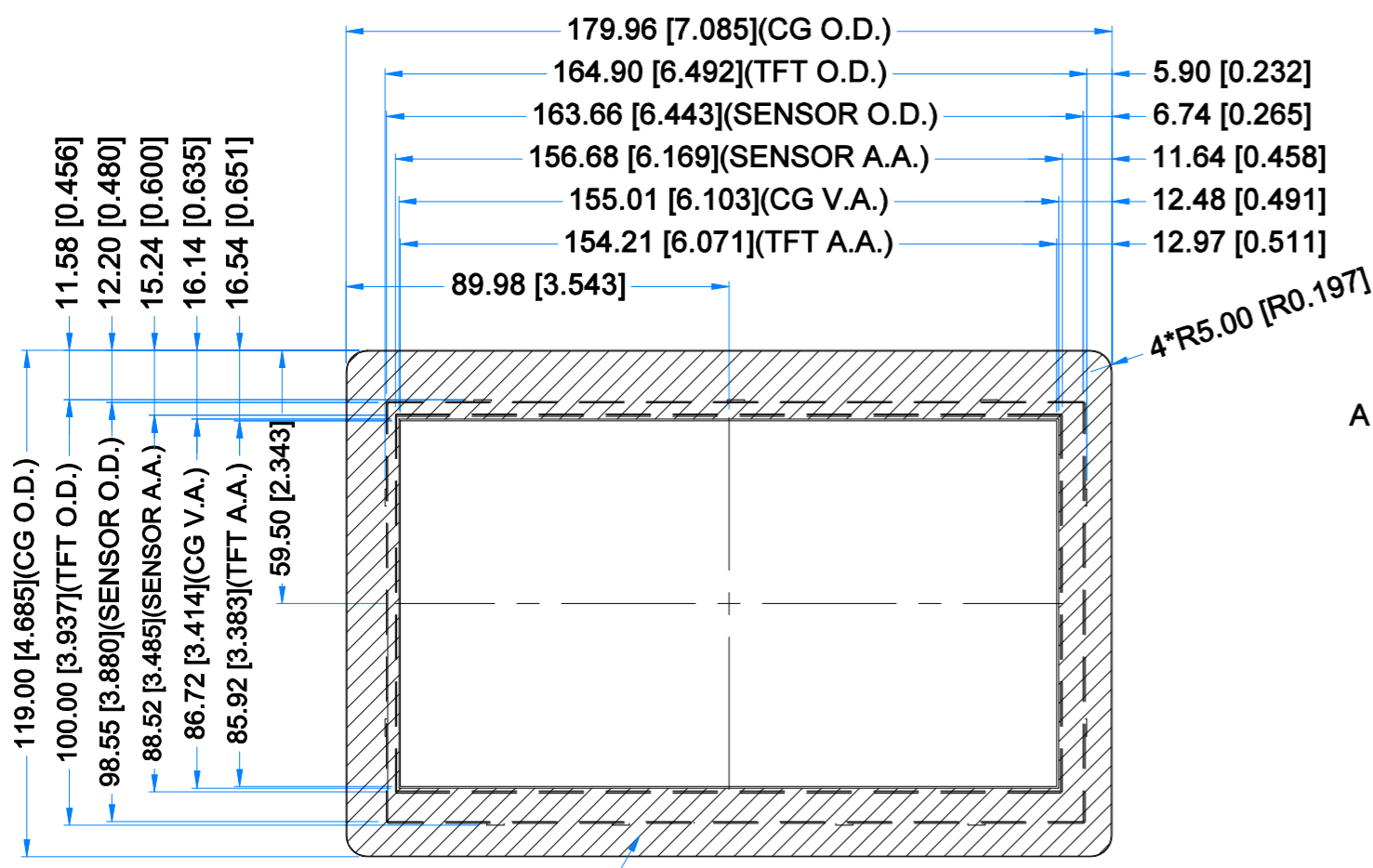

BLACK MASK PRINTING
RAL9005

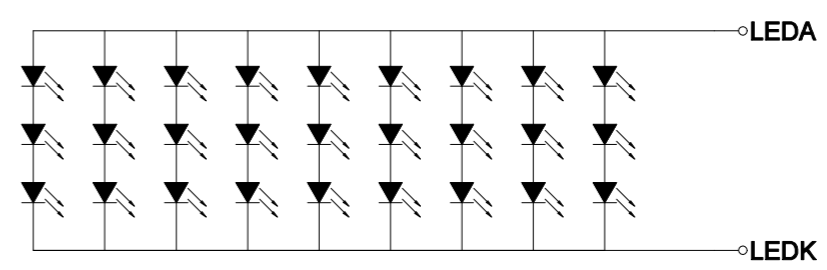
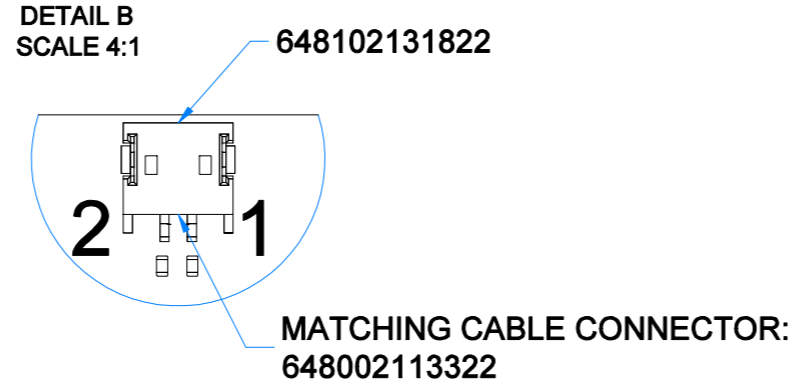
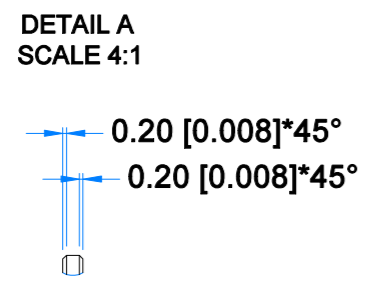
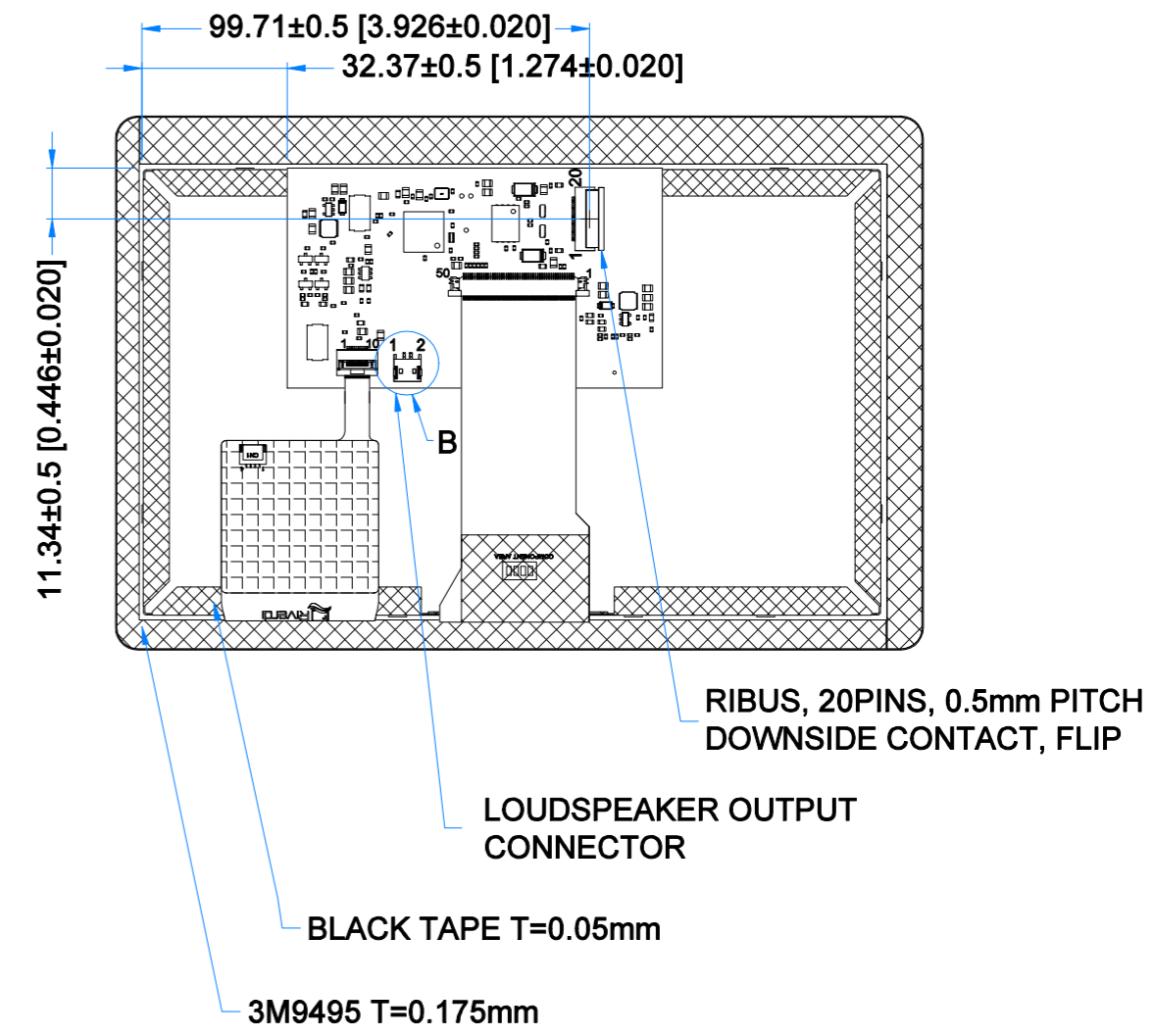
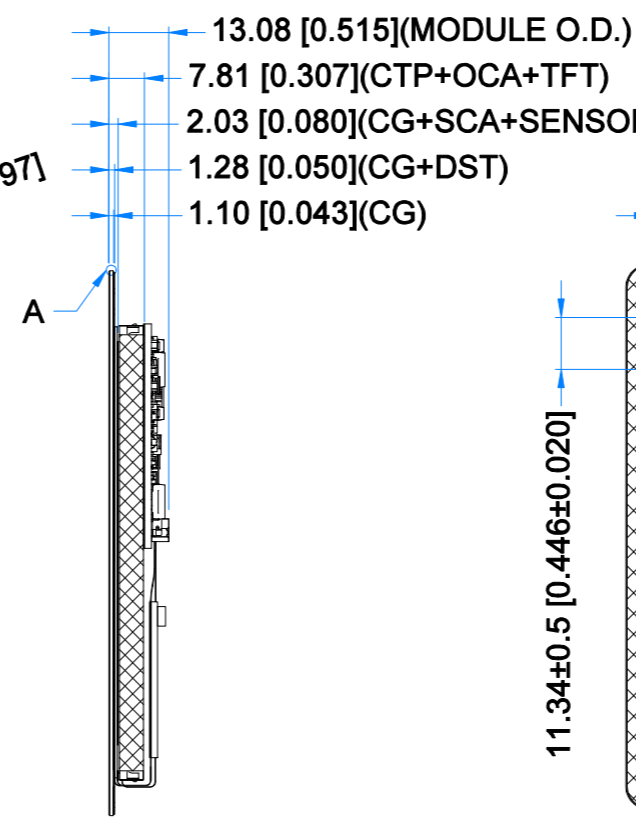

LED Diagram Circuit

LCD NOTES:

- LCD TYPE: TRANSMISSIVE, NORMALLY BLACK, IPS
- RESOLUTION: 1024x600
- VIEWING ANGLE: FREE
- SURFACE LUMINANCE: 850 cd/m²
- DRIVING IC ON THE BOARD: BT817Q
- INTERFACE: SPI/QSPI
- SUPPLY VOLTAGE FOR MODULE: 3.3V
- SUPPLY VOLTAGE FOR BACKLIGHT: 5.0V(TYP.), BUILT-IN LED INVERTER

TP NOTES:

- TP STRUCTURE: G+G
- CG THICKNESS: 1.10 mm
- SURFACE HARDNESS: 7H
- DRIVER IC: ILI2132A
- INTERFACE: SPI/QSPI VIA RIBUS AND BT817Q

GENERAL NOTES:

- OPATICAL BONDING
- OPERATING TEMPERATURE: -20°C ~ 70°C
- STORAGE TEMPERATURE: -30°C ~ 80°C
- WITHOUT INDIVIDUAL TOLERANCE: ±0.3mm
- RoHS3 COMPLIANT

PN: RVT70HSBNWC00-B
SN:
DRAWN: M.Natywa 2021.04.12
CHECKED: K.Brodacka 2021.07.09
APPR:





6. ABSOLUTE MAXIMUM RATINGS

PARAMETER	SYMBOL	MIN	MAX	UNIT	NOTE
Supply Voltage for Module	VDD	0	3.6	V	NOTE 1
Digital I/O signals (SPI/QSPI/GPIO) Voltage	-	-0.5	3.3		NOTE 1, 2
Supply voltage for Backlight	BLVDD	-0.3	5.5		NOTE 1
Operating Temperature	T _{OP}	-20	70	°C	
Storage Temperature	T _{ST}	-30	80	°C	
Storage Humidity (@ 25 ± 5°C)	H _{ST}	10	90	% RH	
Operating Ambient Humidity (@ 25 ± 5°C)	H _{OP}	10	90	% RH	

Note 1. Exceeding the maximum values may cause improper operation or permanent damage to the unit.

Note 2. Digital I/O signals are to be connected to pins 3 ÷ 9, 11 and 12 pins at RiBUS connector (P1).

7. ELECTRICAL CHARACTERISTICS

PARAMETER	SYMBOL	MIN	TYP	MAX	UNIT
Supply Voltage for Module	VDD	3.0	3.3	3.6	V
Current drawn from VDD	I _{VDD}	TBD	235	TBD	mA
Input Voltage "H" Level	V _{IH}	2.0	-	3.3	V
Input Voltage "L" Level	V _{IL}	-	-	0.8	V

8. BACKLIGHT ELECTRICAL CHARACTERISTICS

PARAMETER	SYMBOL	MIN	TYP	MAX	UNIT	NOTE
Supply Voltage for Backlight	BLVDD	TBD	5.0	6.0	V	
Current drawn from BLVDD @5.0V	I _{BLVDD=5.0V}	TBD	362	TBD	mA	100% of backlight, Note 1
Current drawn from BLVDD@5.0V	I _{BLVDD=5.0V}	TBD	173	TBD		50% of backlight, Note 1
Current drawn from BLVDD @3.3V	I _{BLVDD=3.3V}	TBD	1086	TBD		100% of backlight, Note 1
Current drawn from BLVDD@3.3V	I _{BLVDD=3.3V}	TBD	424	TBD		50% of backlight, Note 1
Lifetime	-	-	50,000	-	hours	Note 2

Note 1. Backlight intensity is driven by BT817Q controller by PWM wave from GPIO pin. Please refer to subchapter 11.4.

Note 2. Operating life means the period in which the LED brightness goes down to 50% of the initial brightness. Typical operating lifetime is the estimated parameter.



9. ELECTRO-OPTICAL CHARACTERISTICS

Optical characteristics are determined after the unit has been 'ON' and stable for approximately 30 minutes in a dark environment at 25 °C. The values specified are at an approximate distance 500mm from the LCD surface at a viewing angle of Φ and θ equal to 0°.

ITEM	SYMBOL	CONDITION	MIN	TYP	MAX	UNIT	RMK	NOTE
Response Time	Tr+Tf	$\theta=0^\circ$ $\phi=0^\circ$ Ta=25 °C	-	35	-	ms	FIG 2.	4
Contrast Ratio	Cr		-	800	-	---	FIG 3.	1
Luminance Uniformity	δ WHITE		-	75	-	%	FIG 3.	3
Surface Luminance	Lv		-	850	-	cd/m ²	FIG 3.	2
Viewing Angle Range	θ	$\phi = 90^\circ$	-	85	-	deg	FIG 4.	6
		$\phi = 270^\circ$	-	85	-	deg	FIG 4.	
		$\phi = 0^\circ$	-	85	-	deg	FIG 4.	
		$\phi = 180^\circ$	-	85	-	deg	FIG 4.	
CIE (x, y) Chromaticity	Rx	$\theta=0^\circ$ $\phi=0^\circ$ Ta=25 °C	0.578	0.618	0.658	-	FIG 3.	5
	Ry		0.489	0.329	0.369	-		
	Gx		0.376	0.416	0.456	-		
	Gy		0.493	0.533	0.573	-		
	Bx		0.071	0.111	0.151	-		
	By		0.108	0.148	0.188	-		
	Wx		0.270	0.310	0.350	-		
	Wy		0.290	0.330	0.370	-		

Note 1. Contrast Ratio (CR) is defined mathematically as below, for more information see Figure 3.

$$\text{Contrast Ratio} = \frac{\text{Average Surface Luminance with all white pixels (P1, P2, P3, P4, P5)}}{\text{Average Surface Luminance with all black pixels (P1, P2, P3, P4, P5)}}$$

Note 2. Surface luminance is the LCD surface from the surface with all pixels displaying white. For more information see Figure 3.

$$L_v = \text{Average Surface Luminance with all white pixels (P1, P2, P3, P4, P5)}$$

Note 3. The uniformity in surface luminance δ WHITE is determined by measuring luminance at each test position 1 through 5, and then dividing the minimum luminance of 5 points luminance by maximum luminance of 5 points luminance. For more information see Figure 3.

$$\delta \text{ WHITE} = \frac{\text{Minimum Surface Luminance with all white pixels (P1, P2, P3, P4, P5)}}{\text{Maximum Surface Luminance with all white pixels (P1, P2, P3, P4, P5)}}$$

Note 4. Response time is the time required for the display to transition from white to black (Rise Time, Tr) and from black to white (Decay Time, Tf). For additional information see Figure 2. The test equipment is Autronic-Melchers's ConoScope series.

Note 5. CIE (x, y) chromaticity, the x, y value is determined by measuring luminance at each test position 1 through 5, and then calculating the average value.



Note 6. Viewing angle is the angle at which the contrast ratio is greater than 2. For TFT module the contrast ratio is greater than 10. The angles are determined for the horizontal or x axis and the vertical or y axis with respect to the z axis which is normal to LCD surface. For more information see Figure 4.

Note 7. For viewing angle and response time testing, the testing data is based on Autronic-Melchers's ConoScope series. Instruments for Contrast Ratio, Surface Luminance, Luminance Uniformity, CIE the test data is based on TOPCON's BM-5 photo detector.

Figure 2. The definition of response time

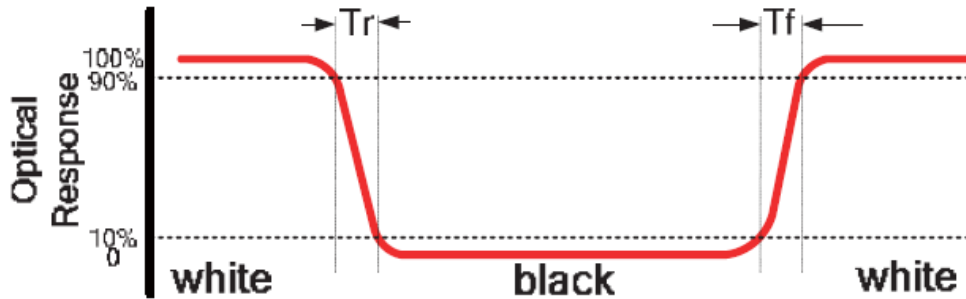
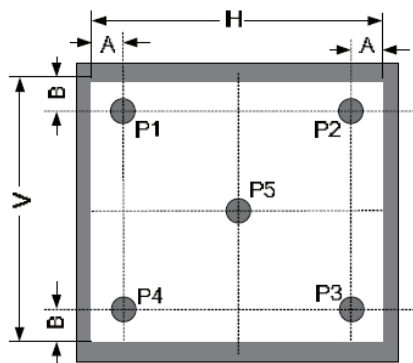

Figure 3. Measuring method for Contrast ratio, surface luminance, Luminance uniformity, CIE (x, y) chromaticity



A: 5mm

B: 5mm

H, V: Active Area

Light spot size $\varnothing=5\text{mm}$, 500mm distance from the LCD surface to detector lens.

Measurement instrument is TOPCON'S luminance meter BM-5

Figure 4. The definition of viewing angle

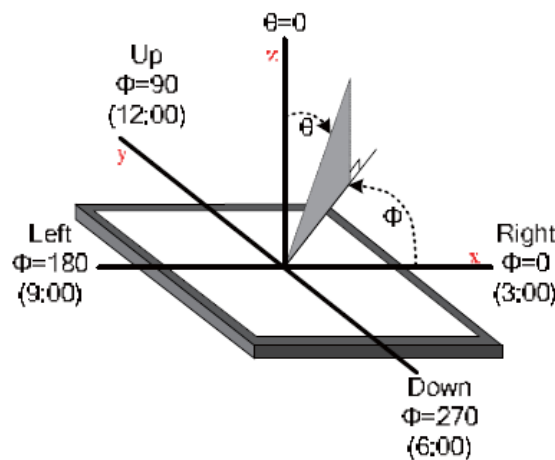



10. INTERFACES DESCRIPTION

10.1 P1 connector - RiBUS description

PIN NO.	CONNECTOR	DESCRIPTION	NOTE
1	VDD	Supply voltage for module; TYP 3.3 V	
2	GND	Ground	
3	SPI_SCLK	SPI SCK signal	
4	MISO/ IO.1	SPI MISO signal / SPI Quad mode: SPI data line 1	
5	MOSI/ IO.0	SPI MOSI signal / SPI Quad mode: SPI data line 0	
6	CS	SPI chip select signal	
7	INT	Interrupt signal from device to the system, Active Low, Internally 47k Pull UP	
8	RST/PD	Reset / Power down signal, Active Low, Internally Pulled UP 47k	
9	GPIO.0	GPIO.0	
10	DISP_AUDIO	Display audio in/out	NOTE 1
11	GPIO.1/IO.2	SPI Single/Dual mode: General purpose IO0. QSPI mode: SPI data line 2	
12	GPIO.2/IO.3	SPI Single/Dual mode: General purpose IO1. QSPI mode: SPI data line 3	
13	NC	Not connected	
14	NC	Not connected	
15	NC	Not connected	
16	NC	Not connected	
17	BLVDD	Supply voltage for backlight	
18	BLVDD	Supply voltage for backlight	
19	BLGND	Backlight Ground, Internally connected to GND	
20	BLGND	Backlight Ground, Internally connected to GND	

Note 1. Requirements for audio external signal voltage will be announced after samples have been tested.

10.2 P2 connector description

PIN NO.	SYMBOL	DESCRIPTION	NOTE
1	SPEAKER +	Speaker coil "+" terminal	NOTE 1
2	SPEAKER -	Speaker coil "-" terminal	

The audio circuit allows for the following 3 things:

1. To play sounds from BT817Q on internal amplifier U3.
2. To play sounds from host on internal amplifier U3.
3. To play sounds from BT817Q on external amplifier.

Note 1. A matched louder speaker for Riverdi's all EVE4 series displays, RVA-SPK1.5W-C150, is developed by Riverdi. Below is the link to this accessory.

<https://riverdi.com/product/rva-spk1-5w-c150/>



Figure 5. The simplified audio circuit design

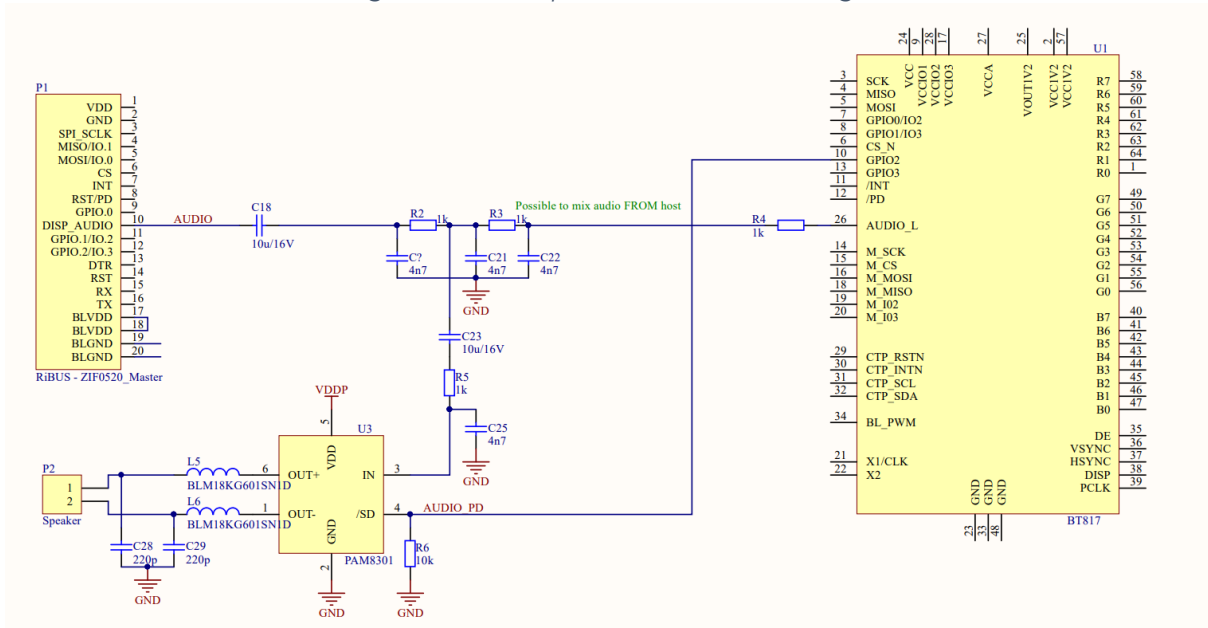

Note 2. Controller board in RVT70HSBNWC00-B is equipped with the separate 512Mb flash memory chip, which allows to store up to 170 full resolution (1024 * 600 pixels, JPG) images. If you need to change the memory size, please contact us: contact@riverdi.com

11. BT817Q CONTROLLER SPECIFICATION

BT817Q or EVE4 (Embedded Video Engine 4) simplifies the system architecture for advanced human machine interfaces (HMIs) by providing functionality for display, audio, and touch as well as an object-oriented architecture approach that extends from display creation to the rendering of the graphics.

11.1 Serial host interface

Figure 6. SPI single/dual interface connection

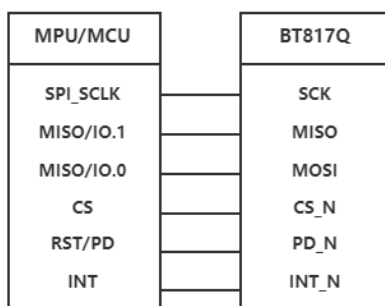
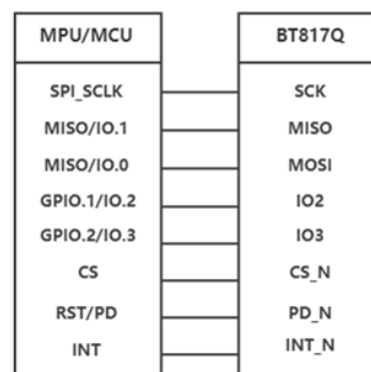

Figure 7. QSPI interface connection



SPI Interface – the SPI slave interface operates up to 30MHz (It depends on EVE4 system clock frequency and needs verification in Riverdi lab).

Only SPI mode 0 is supported. The SPI interface is selected by default.

QSPI Interface – the QSPI slave interface operates up to 30MHz (It depends on EVE 4 system clock frequency and will be verified in Riverdi lab). Only SPI mode 0 is supported.

The QSPI can be configured as a SPI slave in SINGLE, DUAL or QUAD channel modes.

By default, the SPI slave operates in the SINGLE channel mode with MOSI as input from the master and MISO as output to the master. DUAL and QUAD channel modes can be configured through the SPI slave itself. To change the channel modes, write to register REG_SPLWIDTH.

11.2 Block Diagram

Figure 8. BT817Q Block diagram

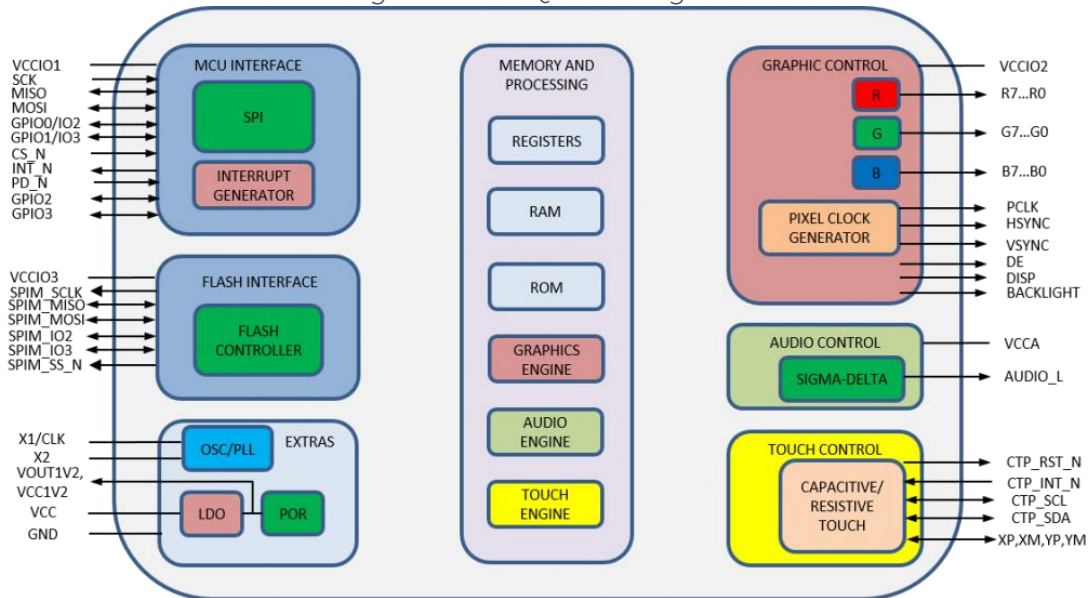

11.3 Host interface SPI mode 0

Figure 9. SPI timing diagram

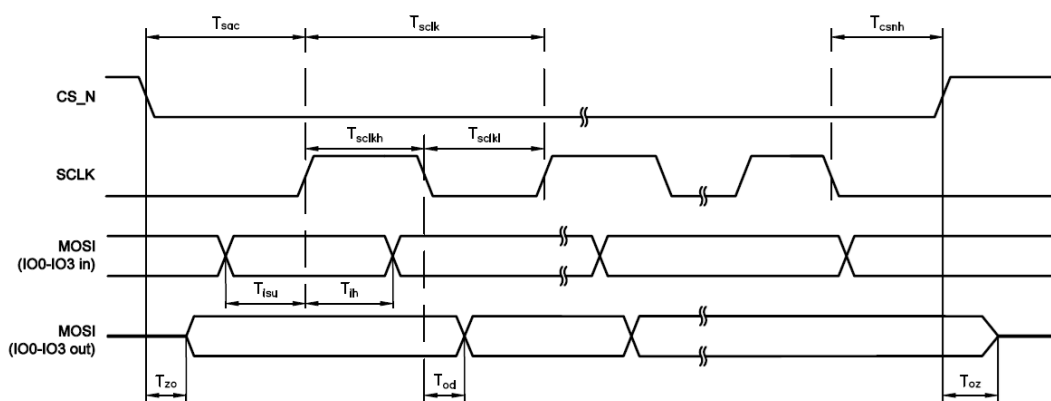

The meanings of the timings in the Figure 9 are defined in the table below.



PARAMETER	DESCRIPTION	VCCIO=1.8V		VCCIO=2.5V		VCCIO=3.3V		UNIT
		Min	Max	Min	Max	Min	Max	
T _{sclk}	SPI clock period	33.3	-	33.3	-	33.3	-	ns
T _{sckl}	SPI clock low duration	13	-	13	-	13	-	
T _{sckh}	SPI clock high duration	13	-	13	-	13	-	
T _{sac}	SPI access time	4	-	3.5	-	3	-	
T _{isu}	Input Setup	4	-	3.5	-	3	-	
T _{ih}	Input Hold	0	-	0	-	0	-	
T _{zo}	Output enable delay	-	16	-	13	11	-	
T _{oz}	Output disable delay	-	13	-	11	10	-	
T _{od}	Output data delay	-	15	-	12	11	-	
T _{csnh}	CSN hold time	0	-	0	-	0	-	

For more information about BT817Q controller please go to official BT81x website.
<https://brtchip.com/bt81x/>

11.4 Backlight driver block diagram

Backlight enable signal is internally connected to BT817Q backlight control pin. This pin is controlled by two BT817Q's registers. One of them specifies the PWM output frequency, second one specifies the duty cycle. Refer to BT817Q datasheet for more information. After we have done the test on samples, more detailed description will be given in this document.

Figure 10. Backlight driver block diagram

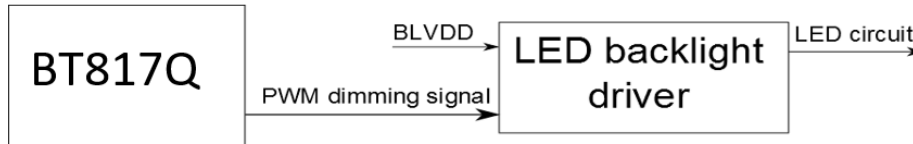

The LED backlight driver used in this module does not burst the LED current. Therefore, it does not generate audible noises on the output capacitor. It is equipped with soft start subsystem, which increases LED life time, as LED current peaks are reduced significantly.



12. TFT LCD TIMING CHARACTERISTICS

12.1 Horizontal input timing

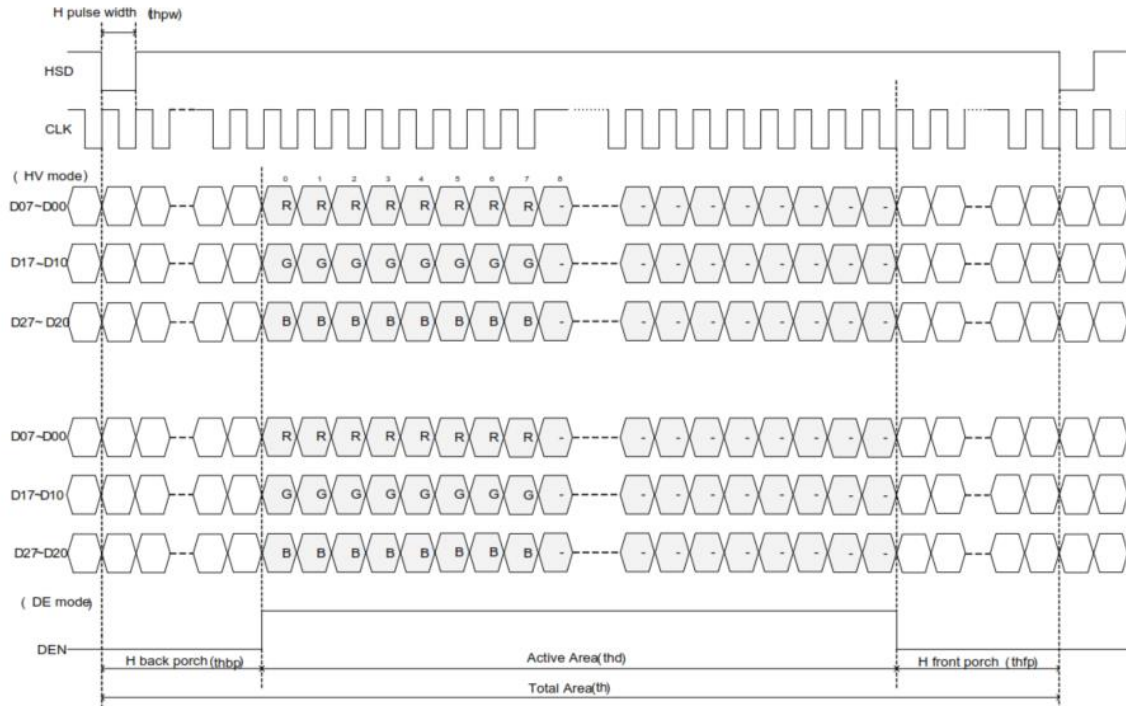

12.2 Vertical input timing

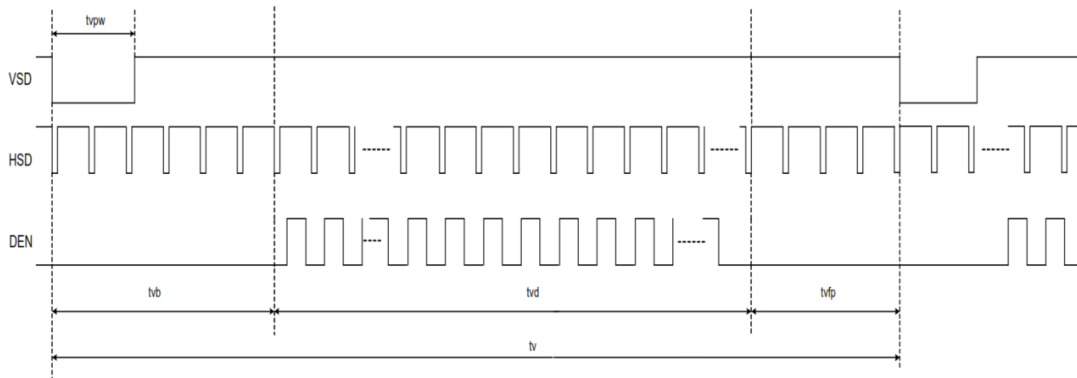



12.3 Parallel RGB timing characteristics

Note: DE/SYNC mode select. Pin is internally pulled high. H: DE Mode. L: HS/VS mode. When select DE mode, MODE = "1", VS and HS must be pulled high.

12.3.1 DE MODE

PARAMETER	SYMBOL	VALUE			UNIT
		MIN.	TYP.	MAX.	
DCLK frequency (Frame rate 60Hz)	f_{clk}	40.8	51.2	67.2	MHz
Horizontal display area	t_{hd}	1024			DCLK
HSYNC period time	t_h	1114	1344	1400	
HSYNC blanking	$t_{hb}+t_{hfp}$	90	320	376	
Vertical display area	t_{vd}	600			H
VSYNC period time	t_v	610	635	800	
VSYNC blanking	$t_{vb}+t_{vfp}$	10	85	200	

12.3.2 HV MODE - Horizontal input timing

PARAMETER	SYMBOL	VALUE			UNIT
		MIN.	TYP.	MAX.	
Horizontal display area	t_{hd}	1024			DCLK
DCLK frequency (frame rate 60Hz)	f_{clk}	44.9	51.2	63	MHz
1 Horizontal Line	t_h	1200	1344	1400	DCLK
HSYNC pulse width	t_{hpw}	1	-	140	
HSYNC back porch	t_{hbp}	160	160	160	
HSYNC front porch	t_{hfp}	16	160	216	

12.3.3 HV MODE - Vertical input timing

PARAMETER	SYMBOL	VALUE			UNIT
		MIN.	TYP.	MAX.	
Vertical display area	t_{vd}	600			H
VSYNC period time	t_v	624	635	750	
VSYNC pulse width	t_{vpw}	1	-	20	
VSYNC back porch	t_{vb}	23	23	23	
VSYNC front porch	t_{vfp}	1	12	127	



13. CAPACITIVE TOUCH SCREEN PANEL SPECIFICATIONS

13.1 Mechanical characteristics

DESCRIPTION	SPECIFICATION	REMARK
Touch Panel Size	7.0 inch	uxTouch
Outline Dimension of CTP	179.96 mm x 119.00 mm	
Product Thickness	2.03mm	
Glass Thickness	1.1 mm	
CTP View Area	155.01 mm x 86.72 mm	
Sensor Active Area	156.68 mm x 88.52 mm	
Structure type	Glass + Glass	
Surface Hardness	7H	

13.2 Electrical characteristics

DESCRIPTION	SPECIFICATION	REMARK	
Power Consumption (IDD)	Active Mode	96 mA	Note 1
	Sleep Mode	10 mA	Note 1
Linearity		+/- 1.5mm	
Controller		ILI2132A	
Resolution		1024 x 600	

Note 1. These 2 values will be verified on the real samples.



14. MODULE INITIALIZATION

1. There is no need to set touch calibration matrix (REG_TOUCH_TRANSFORM_A-F registers in BT817Q) as touch panel resolution and orientation are the same as display, so default values in BT817Q are correct.
2. Initialization data, timings and example codes are available on the Riverdi GitHub, at address: <https://github.com/riverdi/riverdi-eve>
3. REGISTER VALUES:

REG_HSIZE	1024
REG_VSIZE	600
REG_HCYCLE	1344
REG_HOFFSET	160
REG_HSYNCO	0
REG_HSYNC1	70
REG_VCYCLE	635
REG_VOFFSET	23
REG_VSYNCO	0
REG_VSYNC1	10
REG_PCLK	1
REG_SWIZZLE	0
REG_PCLK_POL	1
REG_CSPREAD	0
REG_DITHER	0
REG_PCLK_FREQ	0xD12
REG_PCLK_2X	0

15. INSPECTION

Standard acceptance/rejection criteria for TFT module

15.1 Inspection condition

Ambient conditions:

- Temperature: $25 \pm 2^{\circ}\text{C}$
- Humidity: $(60 \pm 10) \%RH$
- Illumination: Single fluorescent lamp non-directive (300 to 700 lux)

Viewing distance: $35 \pm 5\text{cm}$ between inspector bare eye and LCD.

Viewing Angle: U/D: $45^{\circ}/45^{\circ}$, L/R: $45^{\circ}/45^{\circ}$

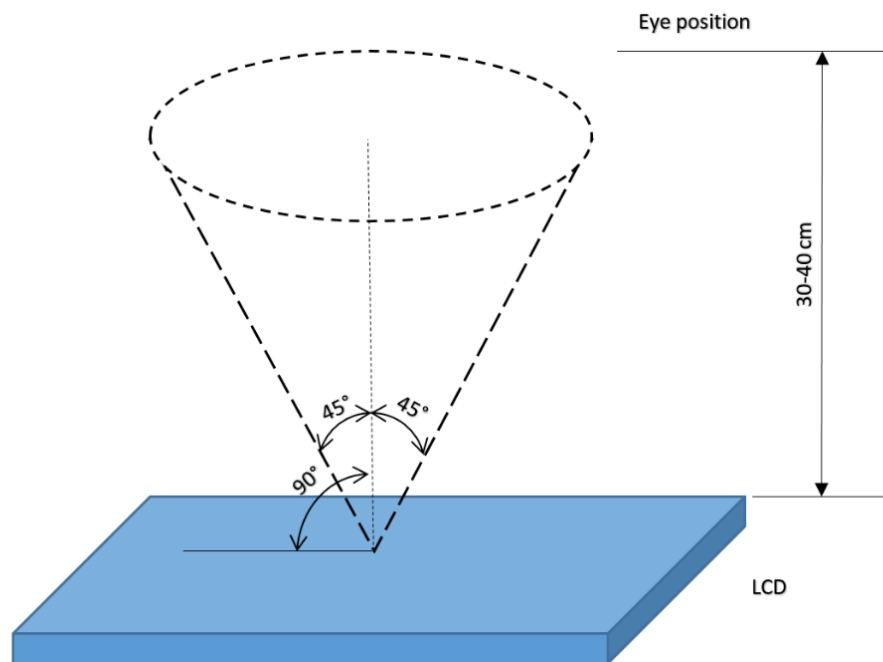

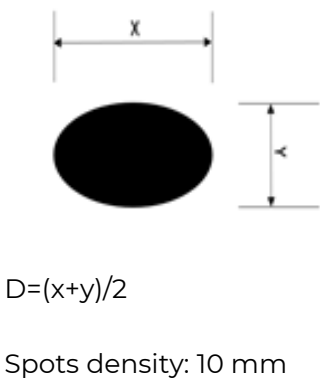
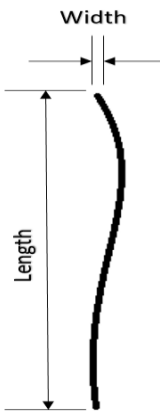

15.2 Inspection standard

ITEM		CRITERION		
Black spots, white spots, light leakage, Foreign Particle (round Type)		Size =7"		
		Average Diameter	Qualified Qty	
		$D \leq 0.2 \text{ mm}$	Ignored	
		$0.2 \text{ mm} < D \leq 0.3 \text{ mm}$	N≤3	
		$0.5\text{mm} < D$	Not allowed	
LCD black spots, white spots, light leakage (line Type)		Size =7"		
		Length	Width	Qualified Qty
		-	$W \leq 0.05$	Ignored
		$L \leq 5.0$	$0.05 < W \leq 0.1$	3
		$5.0 < L$	$0.10 < W$	Not allowed
Bright/Dark Dots	Size =7"			
	Item	Qualified Qty		
	Bright dots	$N \leq 2$		
	Dark dots	$N \leq 3$		
	Total Bright and Dark Dots	$N \leq 4$		
Clear spots	Size ≥ 5"			
	Average Diameter	Qualified Qty		
	$D < 0.2 \text{ mm}$	Ignored		
	$0.2 \text{ mm} < D < 0.3 \text{ mm}$	4		
	$0.3 \text{ mm} < D < 0.5 \text{ mm}$	2		
	$0.5 \text{ mm} < D$	0		
	Spots density: 10 mm			
Polarizer bubbles	Size = 7"			
	Average Diameter	Qualified Qty		
	$D \leq 0.2 \text{ mm}$	Ignored		
	$0.2 \text{ mm} < D \leq 0.5 \text{ mm}$	2		
	$0.5 \text{ mm} < D$	1		
Touch panel spots	Size ≥ 5"			
	Average Diameter	Qualified Qty		
	$D < 0.25 \text{ mm}$	Ignored		
	$0.25 \text{ mm} < D < 0.5 \text{ mm}$	4		



	0.5 mm < D		0
Touch panel white line scratch	Size ≥ 5"		
	Length	Width	Qualified Qty
	-	W < 0.03	Ignored
	L < 5.0	0.03 < W < 0.05	2
	-	0.05 < W	0

16.RELIABILITY TEST

NO.	TEST ITEM	TEST CONDITION	NOTE
1	High Temperature Storage	80°C/120 hours	Note 1
2	Low Temperature Storage	-30°C/120 hours	
3	High Temperature Operating	70 °C /120 hours	
4	Low Temperature Operating	-20°C/120 hours	
5	High Temperature and High Humidity	Humidity 40°C, 90%RH, 120Hrs	
6	Thermal Cycling Test (No operation)	-20°C for 30min, 70°C for 30 min. 100 cycles. Then test at room temperature after 1 hour	Note 2
7	Vibration Test	Frequency: 10 ÷ 55 Hz. Stroke: 1.5 mm. Sweep: 10Hz ÷ 55Hz ÷ 10 Hz. 2 hours for each direction of X, Y, Z (Total 6 hours)	
8	Package Drop Test	Height: 60 cm 1 corner, 3 edges, 6 surfaces	

Note 1. Sample quantity for each test item is 5 ÷ 10 pcs.

Note 2. Before cosmetic and function test, the product must have enough recovery time, at least 2 hours at room temperature.



17.LEGAL INFORMATION

Riverdi grants the guarantee for the proper operation of the goods for a period of 12 months from the date of possession of the goods. If in a consequence of this guaranteed execution the customer has received the defects-free item as replacement for the defective item, the effectiveness period of this guarantee shall start anew from the moment the customer receives the defects-free item.

Information about device is the property of Riverdi and may be the subject of patents pending or granted. It is not allowed to copy or disclosed this document without prior written permission.

Riverdi endeavors to ensure that all contained information in this document is correct but does not accept liability for any error or omission. Riverdi products are in developing process and published information may be not up to date. Riverdi reserves the right to update and makes changes to Specifications or written material without prior notice at any time. It is important to check the current position with Riverdi.

Images and graphics used in this document are only for illustrative the purpose. All images and graphics are possible to be displayed on the range products of Riverdi, however the quality may vary. Riverdi is no liable to the buyer or to any third party for any indirect, incidental, special, consequential, punitive or exemplary damages (including without limitation lost profits, lost savings, or loss of business opportunity) relating to any product, service provided or to be provided by Riverdi, or the use or inability to use the same, even if Riverdi has been advised of the possibility of such damages.

Riverdi products are not fault tolerant nor designed, manufactured or intended for use or resale as on line control equipment in hazardous environments requiring fail-safe performance, such as in the operation of nuclear facilities, aircraft navigation or communication systems, air traffic control, direct life support machines or weapons systems in which the failure of the product could lead directly to death, personal injury or severe physical or environmental damage ('High-Risk Activities'). Riverdi and its suppliers specifically disclaim any expressed or implied warranty of fitness for High-Risk Activities. Using Riverdi products and devices in 'High-Risk Activities' and in any other application is entirely at the buyer's risk, and the buyer agrees to defend, indemnify and hold harmless Riverdi from all damages, claims or expenses resulting from such use. No licenses are conveyed, implicitly or otherwise, under any Riverdi intellectual property rights.

Hi, I am here to help you!
If you have any additional
questions, please contact
our support via email:
contact@riverdi.com



Mouser Electronics

Authorized Distributor

Click to View Pricing, Inventory, Delivery & Lifecycle Information:

Riverdi:

[RVT70HSBNWC00-B](#)