

NHD-0216BZ-RN-GBW

Character Liquid Crystal Display Module

NHD- Newhaven Display
0216- 2 Lines x 16 Characters
BZ- Model
R- Reflective
N- No Backlight
G- STN Gray, Positive
B- 6:00 Optimal View
W- Wide Temperature
RoHS Compliant

Newhaven Display International, Inc.

2661 Galvin Ct.

Elgin IL, 60124

Ph: 847-844-8795

Fax: 847-844-8796

www.newhavendisplay.com

nhtech@newhavendisplay.com

nhsales@newhavendisplay.com

Document Revision History

| Revision | Date | Description | Changed by |
|----------|------------|---|------------|
| 0 | 10/8/2007 | Initial Release | - |
| 1 | 12/21/2009 | User Guide Reformat | BE |
| 2 | 1/7/2010 | Optical revised | BE |
| 3 | 1/6/2011 | Alternate controller information updated | AK |
| 4 | 5/3/2011 | Electrical characteristics updated | AK |
| 5 | 10/27/16 | Mech. Drawing, Elect & Optical Characteristic Updated | TM |

Functions and Features

- 2 lines x 16 characters
- Built-in controller (ST7066U)
- +5.0V Power Supply
- 1/16 duty, 1/5 bias
- RoHS compliant

Mechanical Drawing

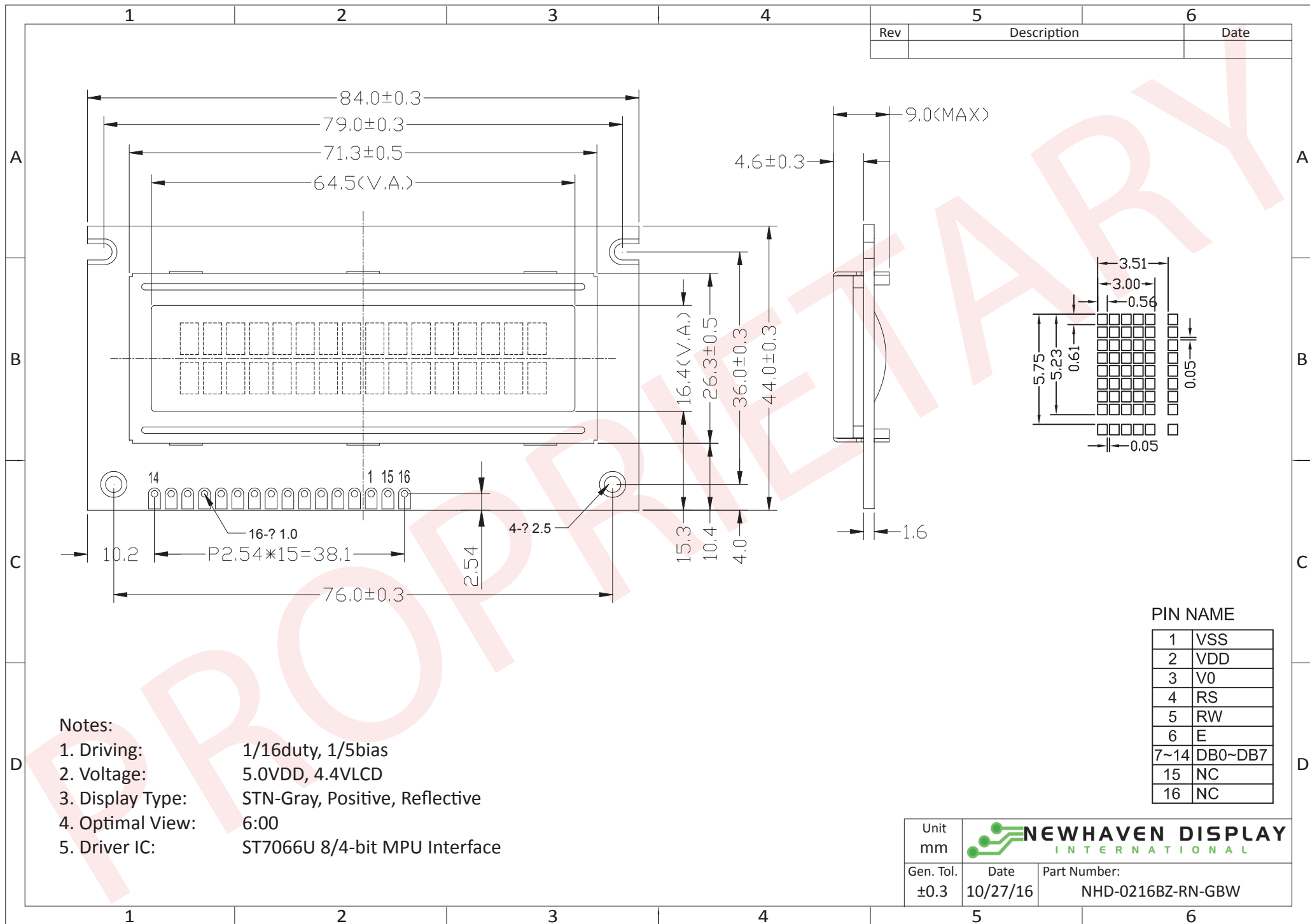

- Notes:
- 1. Driving: 1/16duty, 1/5bias
 - 2. Voltage: 5.0VDD, 4.4VLCD
 - 3. Display Type: STN-Gray, Positive, Reflective
 - 4. Optimal View: 6:00
 - 5. Driver IC: ST7066U 8/4-bit MPU Interface

| | | |
|-------------------|--|-----------------------------------|
| Unit mm | NEWHAVEN DISPLAY INTERNATIONAL | |
| Gen. Tol. ±0.3 | Date 10/27/16 | Part Number: NHD-0216BZ-RN-GBW |

Pin Description and Wiring Diagram

| Pin No. | Symbol | External Connection | Function Description |
|---------|-----------------|---------------------|---|
| 1 | V _{SS} | Power Supply | Ground |
| 2 | V _{DD} | Power Supply | Voltage for logic (+5.0V) |
| 3 | V ₀ | Adj Power Supply | Voltage for contrast (approx. 0.6V) |
| 4 | RS | MPU | Register Select signal. RS=0: Command, RS=1: Data |
| 5 | R/W | MPU | Read/Write select signal, R/W=1: Read R/W=0: Write |
| 6 | E | MPU | Operation Enable signal. Falling edge triggered. |
| 7-10 | DB0 – DB3 | MPU | Four low order bi-directional three-state data bus lines. These four are not used during 4-bit operation. |
| 11-14 | DB4 – DB7 | MPU | Four high order bi-directional three-state data bus lines. |
| 15 | NC | - | No Connect |
| 16 | NC | - | No Connect |

Recommended LCD connector: 2.54mm pitch pins

Backlight connector: --- Mates with: ---

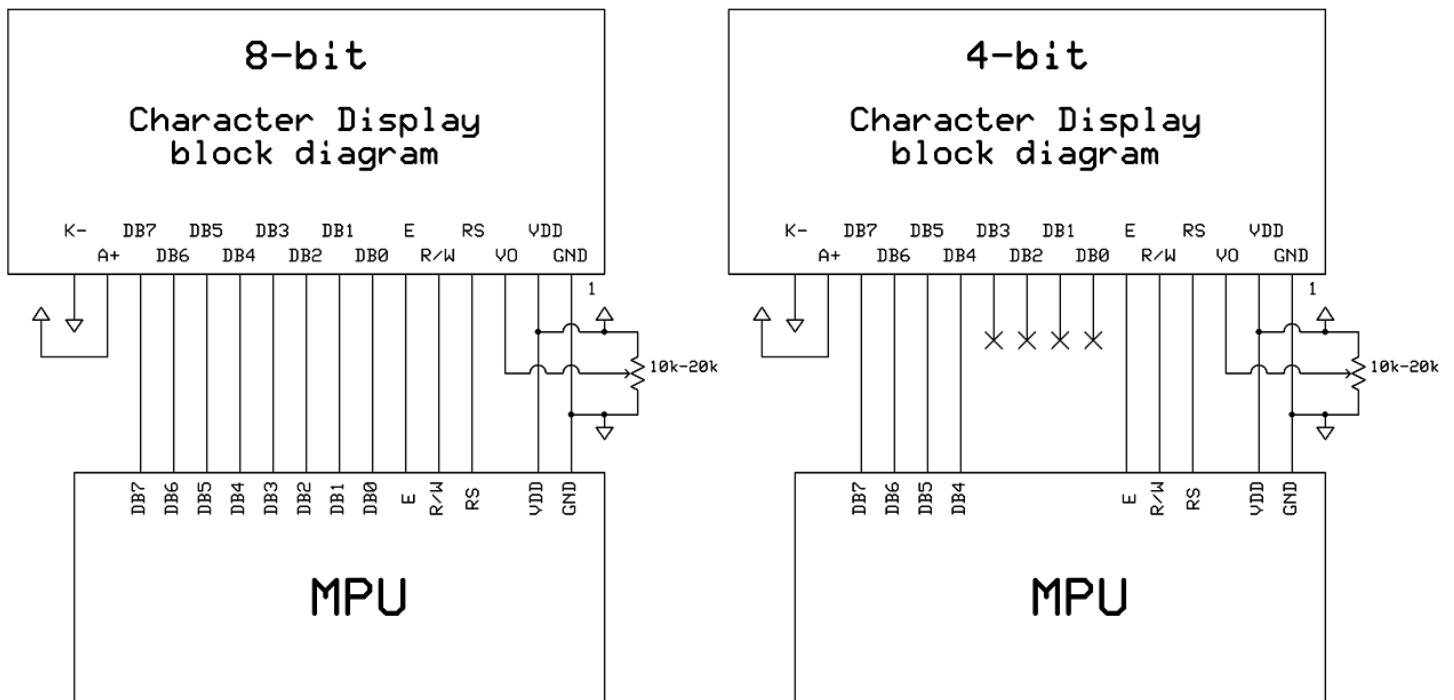

Electrical Characteristics

| Item | Symbol | Condition | Min. | Typ. | Max. | Unit |
|-----------------------------|-----------|---|--------------------|------|----------|------|
| Operating Temperature Range | T_{OP} | Absolute Max | -20 | - | +70 | °C |
| Storage Temperature Range | T_{ST} | Absolute Max | -30 | - | +80 | °C |
| Supply Voltage | V_{DD} | - | 4.8 | 5.0 | 5.2 | V |
| Supply Current | I_{DD} | $T_{OP} = 25^{\circ}C$, $V_{DD} = 5.0V$ | 1.0 | 1.5 | 2.5 | mA |
| Supply for LCD (contrast) | V_{LCD} | | 4.2 | 4.4 | 4.6 | V |
| "H" Level input | V_{IH} | - | $0.7 \cdot V_{DD}$ | - | V_{DD} | V |
| "L" Level input | V_{IL} | - | V_{SS} | - | 0.6 | V |
| "H" Level output | V_{OH} | - | 3.9 | - | V_{DD} | V |
| "L" Level output | V_{OL} | - | V_{SS} | - | 0.4 | V |
| Backlight Supply Voltage | V_{LED} | - | - | - | - | V |
| Backlight Supply Current | I_{LED} | - | - | - | - | mA |

Optical Characteristics

| Item | Symbol | Condition | Min. | Typ. | Max. | Unit |
|------------------------|--------|------------------------|------|------|------|------|
| Optimal Viewing Angles | Top | $CR \geq 2$ | - | 40 | - | ° |
| | Bottom | | - | 60 | - | ° |
| | Left | | - | 60 | - | ° |
| | Right | | - | 60 | - | ° |
| Contrast Ratio | CR | - | 2 | 5 | - | - |
| Response Time | Rise | $T_{OP} = 25^{\circ}C$ | - | 150 | 250 | ms |
| | Fall | | - | 200 | 300 | ms |

Controller Information

Built-in ST7066U Controller.

Please download specification at http://www.newhavendisplay.com/app_notes/ST7066U.pdf

DDRAM Address

| | | | | | | | | | | | | | | | |
|----|----|----|----|----|----|----|----|----|----|----|----|----|----|----|----|
| 1 | 2 | 3 | 4 | 5 | 6 | 7 | 8 | 9 | 10 | 11 | 12 | 13 | 14 | 15 | 16 |
| 00 | 01 | 02 | 03 | 04 | 05 | 06 | 07 | 08 | 09 | 0A | 0B | 0C | 0D | 0E | 0F |
| 40 | 41 | 42 | 43 | 44 | 45 | 46 | 47 | 48 | 49 | 4A | 4B | 4C | 4D | 4E | 4F |

Table of Commands

| Instruction | Instruction code | | | | | | | | | | Description | Execution time (fosc=270 KHZ) | |
|----------------------------|------------------|-----|-----|-----|-----|-----|-----|-----|-----|-----|-------------|--|--------|
| | RS | R/W | DB7 | DB6 | DB5 | DB4 | DB3 | DB2 | DB1 | DB0 | | | |
| Clear Display | 0 | 0 | 0 | 0 | 0 | 0 | 0 | 0 | 0 | 0 | 1 | Write "20H" to DDRAM and set DDRAM address to "00H" from AC | 1.52ms |
| Return Home | 0 | 0 | 0 | 0 | 0 | 0 | 0 | 0 | 0 | 1 | - | Set DDRAM Address to "00H" from AC and return cursor to its original position if shifted. The contents of DDRAM are not changed. | 1.52ms |
| Entry mode Set | 0 | 0 | 0 | 0 | 0 | 0 | 0 | 0 | 1 | I/D | SH | Sets cursor move direction and specifies display shift. These parameters are performed during data write and read. | 37μs |
| Display ON/OFF control | 0 | 0 | 0 | 0 | 0 | 0 | 0 | 1 | D | C | B | D=1: Entire display on C=1: Cursor on B=1: Blinking cursor on | 37μs |
| Cursor or Display shift | 0 | 0 | 0 | 0 | 0 | 0 | 1 | S/C | R/L | - | - | Sets cursor moving and display shift control bit, and the direction without changing DDRAM data. | 37μs |
| Function set | 0 | 0 | 0 | 0 | 1 | DL | N | F | - | - | - | DL: Interface data is 8/4 bits N: Number of lines is 2/1 F: Font size is 5x11/5x8 | 37μs |
| Set CGRAM Address | 0 | 0 | 0 | 1 | AC5 | AC4 | AC3 | AC2 | AC1 | AC0 | | Set CGRAM address in address counter | 37μs |
| Set DDRAM Address | 0 | 0 | 1 | AC6 | AC5 | AC4 | AC3 | AC2 | AC1 | AC0 | | Set DDRAM address in address counter. | 37μs |
| Read busy Flag and Address | 0 | 1 | BF | AC6 | AC5 | AC4 | AC3 | AC2 | AC1 | AC0 | | Whether during internal operation or not can be known by reading BF. The contents of address counter can also be read. | 0s |
| Write data To Address | 1 | 0 | D7 | D6 | D5 | D4 | D3 | D2 | D1 | D0 | | Write data into internal RAM (DDRAM/CGRAM). | 37μs |
| Read data From RAM | 1 | 1 | D7 | D6 | D5 | D4 | D3 | D2 | D1 | D0 | | Read data from internal RAM (DDRAM/CGRAM). | 37μs |

Timing Characteristics

Writing data from MPU to ST7066U

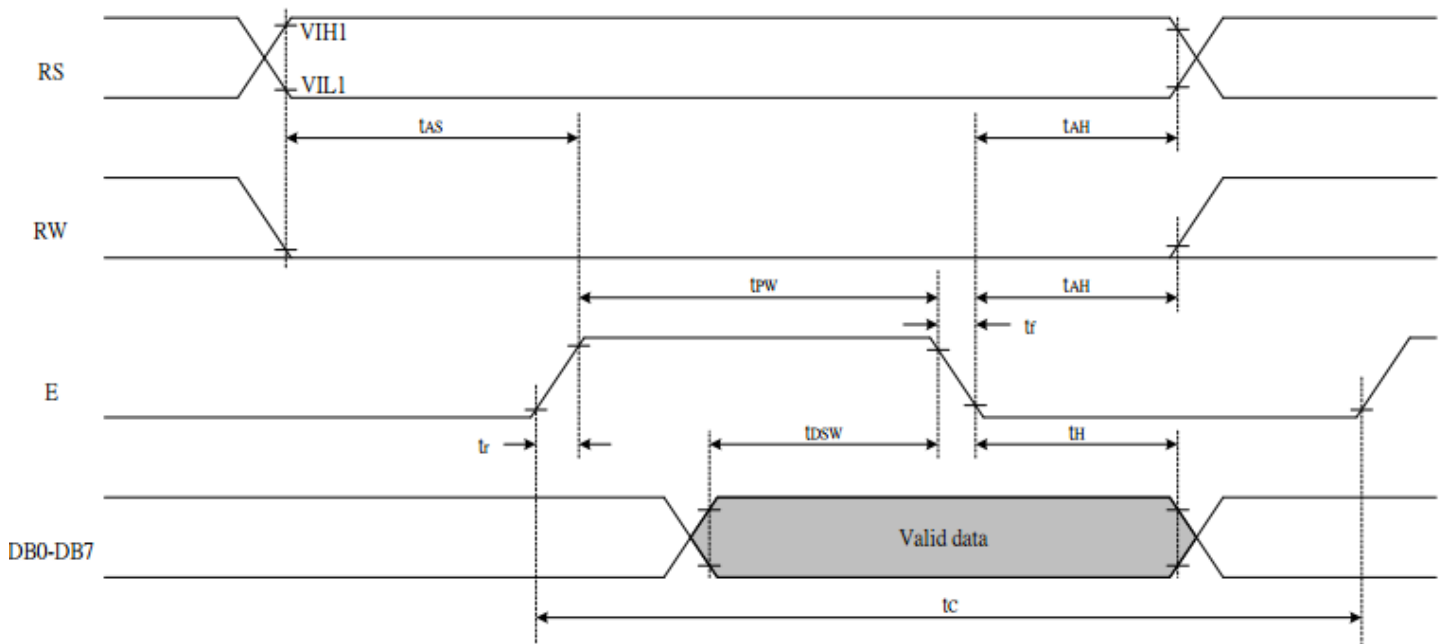

| Write Mode (Writing data from MPU to ST7066U) | | | | | | |
|---|-----------------------|-----------------|------|---|----|----|
| T_C | Enable Cycle Time | Pin E | 1200 | - | - | ns |
| T_{PW} | Enable Pulse Width | Pin E | 140 | - | - | ns |
| T_R, T_F | Enable Rise/Fall Time | Pin E | - | - | 25 | ns |
| T_{AS} | Address Setup Time | Pins: RS,RW,E | 0 | - | - | ns |
| T_{AH} | Address Hold Time | Pins: RS,RW,E | 10 | - | - | ns |
| T_{DSW} | Data Setup Time | Pins: DB0 - DB7 | 40 | - | - | ns |
| T_H | Data Hold Time | Pins: DB0 - DB7 | 10 | - | - | ns |

Reading data from ST7066U to MPU



| Read Mode (Reading Data from ST7066U to MPU) | | | | | | |
|--|-----------------------|-----------------|------|---|-----|----|
| T_C | Enable Cycle Time | Pin E | 1200 | - | - | ns |
| T_{PW} | Enable Pulse Width | Pin E | 140 | - | - | ns |
| T_R, T_F | Enable Rise/Fall Time | Pin E | - | - | 25 | ns |
| T_{AS} | Address Setup Time | Pins: RS,RW,E | 0 | - | - | ns |
| T_{AH} | Address Hold Time | Pins: RS,RW,E | 10 | - | - | ns |
| T_{DDR} | Data Setup Time | Pins: DB0 - DB7 | - | - | 100 | ns |
| T_H | Data Hold Time | Pins: DB0 - DB7 | 10 | - | - | ns |

Built-in Font Table

| b7-b4 b3-b0 | 0000 | 0001 | 0010 | 0011 | 0100 | 0101 | 0110 | 0111 | 1000 | 1001 | 1010 | 1011 | 1100 | 1101 | 1110 | 1111 |
|----------------|------------------|------|------|------|------|------|------|------|------|------|------|------|------|------|------|------|
| 0000 | CG RAM (1) | | | 0 | a | P | ^ | F | | | | — | 9 | 3 | o | p |
| 0001 | (2) | ! | 1 | A | Q | a | A | | | | e | 7 | 7 | G | ä | g |
| 0010 | (3) | " | 2 | B | R | b | r | | | | r | 4 | 9 | × | B | e |
| 0011 | (4) | # | 3 | C | S | c | s | | | | l | 9 | 7 | e | e | * |
| 0100 | (5) | * | 4 | D | T | d | t | | | | \ | I | f | h | h | a |
| 0101 | (6) | % | 5 | E | U | e | u | | | | . | + | * | 1 | o | o |
| 0110 | (7) | & | 6 | F | V | f | v | | | | 7 | 0 | 二 | 3 | p | Σ |
| 0111 | (8) | ' | 7 | G | W | g | w | | | | 7 | * | 又 | 7 | g | π |
| 1000 | (1) | < | 8 | H | X | h | x | | | | 4 | 9 | * | U | f | 又 |
| 1001 | (2) | > | 9 | I | Y | i | y | | | | o | 9 | 7 | U | 7 | y |
| 1010 | (3) | * | : | J | Z | j | z | | | | z | o | n | v | j | 7 |
| 1011 | (4) | + | : | K | L | k | l | | | | * | 9 | E | o | * | π |
| 1100 | (5) | , | < | L | * | l | l | | | | h | 9 | 7 | 7 | * | π |
| 1101 | (6) | — | = | M | J | m | j | | | | u | 又 | ^ | 7 | t | ÷ |
| 1110 | (7) | . | > | N | ^ | n | ^ | | | | 3 | E | h | ^ | h | |
| 1111 | (8) | / | ? | O | _ | o | ← | | | | u | 9 | 又 | " | o | ■ |

Example Initialization Program

8-bit Initialization:

```

/*****/
void command(char i)
{
    P1 = i;                //put data on output Port
    D_I =0;                //D/I=LOW : send instruction
    R_W =0;                //R/W=LOW : Write
    E = 1;
    Delay(1);              //enable pulse width >= 300ns
    E = 0;                 //Clock enable: falling edge
}
/*****/
void write(char i)
{
    P1 = i;                //put data on output Port
    D_I =1;                //D/I=HIGH : send data
    R_W =0;                //R/W=LOW : Write
    E = 1;
    Delay(1);              //enable pulse width >= 300ns
    E = 0;                 //Clock enable: falling edge
}
/*****/
void init()
{
    E = 0;
    Delay(100);            //Wait >40 msec after power is applied
    command(0x30);         //command 0x30 = Wake up
    Delay(30);             //must wait 5ms, busy flag not available
    command(0x30);         //command 0x30 = Wake up #2
    Delay(10);             //must wait 160us, busy flag not available
    command(0x30);         //command 0x30 = Wake up #3
    Delay(10);             //must wait 160us, busy flag not available
    command(0x38);         //Function set: 8-bit/2-line
    command(0x10);         //Set cursor
    command(0x0c);         //Display ON; Cursor ON
    command(0x06);         //Entry mode set
}
/*****/
```

4-bit Initialization:

```

/*****/
void command(char i)
{
    P1 = i;                //put data on output Port
    D_I = 0;              //D/I=LOW : send instruction
    R_W = 0;              //R/W=LOW : Write
    Nybble();             //Send lower 4 bits
    i = i<<4;             //Shift over by 4 bits
    P1 = i;                //put data on output Port
    Nybble();             //Send upper 4 bits
}
/*****/
void write(char i)
{
    P1 = i;                //put data on output Port
    D_I = 1;              //D/I=HIGH : send data
    R_W = 0;              //R/W=LOW : Write
    Nybble();             //Clock lower 4 bits
    i = i<<4;             //Shift over by 4 bits
    P1 = i;                //put data on output Port
    Nybble();             //Clock upper 4 bits
}
/*****/
void Nybble()
{
    E = 1;
    Delay(1);              //enable pulse width >= 300ns
    E = 0;                 //Clock enable: falling edge
}
/*****/
void init()
{
    P1 = 0;
    P3 = 0;
    Delay(100);           //Wait >40 msec after power is applied
    P1 = 0x30;            //put 0x30 on the output port
    Delay(30);            //must wait 5ms, busy flag not available
    Nybble();             //command 0x30 = Wake up
    Delay(10);            //must wait 160us, busy flag not available
    Nybble();             //command 0x30 = Wake up #2
    Delay(10);            //must wait 160us, busy flag not available
    Nybble();             //command 0x30 = Wake up #3
    Delay(10);            //can check busy flag now instead of delay
    P1 = 0x20;            //put 0x20 on the output port
    Nybble();             //Function set: 4-bit interface
    command(0x28);        //Function set: 4-bit/2-line
    command(0x10);        //Set cursor
    command(0x0F);        //Display ON; Blinking cursor
    command(0x06);        //Entry Mode set
}
/*****/

```

Quality Information

| Test Item | Content of Test | Test Condition | Note |
|---------------------------------------|---|--|------|
| High Temperature storage | Endurance test applying the high storage temperature for a long time. | +80°C , 48hrs | 2 |
| Low Temperature storage | Endurance test applying the low storage temperature for a long time. | -30°C , 48hrs | 1,2 |
| High Temperature Operation | Endurance test applying the electric stress (voltage & current) and the high thermal stress for a long time. | +70°C , 48hrs | 2 |
| Low Temperature Operation | Endurance test applying the electric stress (voltage & current) and the low thermal stress for a long time. | -20°C , 48hrs | 1,2 |
| High Temperature / Humidity Operation | Endurance test applying the electric stress (voltage & current) and the high thermal with high humidity stress for a long time. | +40°C , 90% RH , 48hrs | 1,2 |
| Thermal Shock resistance | Endurance test applying the electric stress (voltage & current) during a cycle of low and high thermal stress. | 0°C, 30min -> 25°C, 5min -> 50°C, 30min = 1 cycle For 10 cycles | |
| Vibration test | Endurance test applying vibration to simulate transportation and use. | 10-55Hz, 15mm amplitude. 60 sec in each of 3 directions X,Y,Z For 15 minutes | 3 |
| Static electricity test | Endurance test applying electric static discharge. | VS=800V, RS=1.5kΩ, CS=100pF One time | |

Note 1: No condensation to be observed.

Note 2: Conducted after 4 hours of storage at 25°C, 0%RH.

Note 3: Test performed on product itself, not inside a container.

Precautions for using LCDs/LCMs

See Precautions at www.newhavendisplay.com/specs/precautions.pdf

Warranty Information

See Terms & Conditions at http://www.newhavendisplay.com/index.php?main_page=terms

Mouser Electronics

Authorized Distributor

Click to View Pricing, Inventory, Delivery & Lifecycle Information:

[Newhaven Display:](#)

[NHD-0216BZ-RN-GBW](#)