

规格书编号

SPEC NO :

# 产品规格书

# SPECIFICATION

CUSTOMER 客户: \_\_\_\_\_  
PRODUCT 产品: **SAW FILTER**  
MODEL NO 型号: **HDBF36A14Dc SIP5Dc**  
PREPARED 编制: \_\_\_\_\_ CHECKED 审核: \_\_\_\_\_  
APPROVED 批准: \_\_\_\_\_ DATE 日期: **2008-11-18**

客户确认 CUSTOMER RECEIVED:		
审核 CHECKED	批准 APPROVED	日期 DATE

无锡市好达电子有限公司  
Shoulder Electronics Limited



**1.SCOPE**

Shoulder’s SAW filter series have broad line up products meeting all broadcast standard including NTSC,PAL and SECAM systems. These filters are composed of two interdigital transducers on a single-crystal. piezoelectrical chip. they are used in electronic equipments such as TV and so on.

**2.Construction**

**2.1 Dimension and materials**

Manufacturer’s name :Shoulder Electronics Limited

Type : BF36A14Dc

Unit: mm

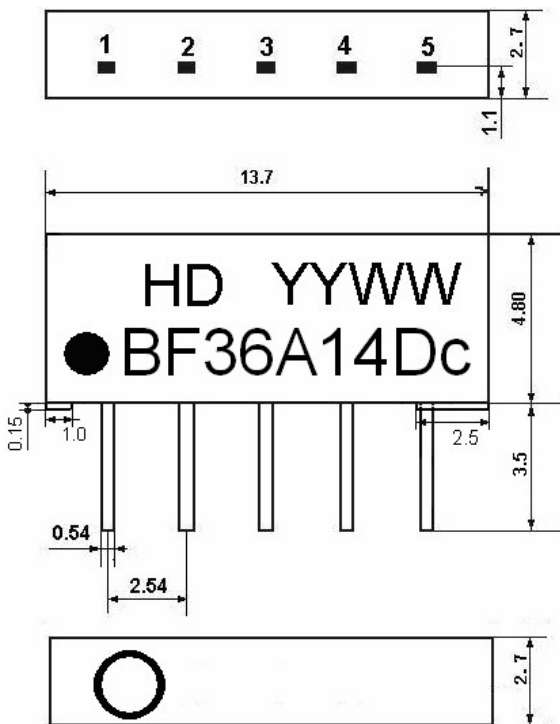

Pin configurations

- 1. Input
- 2. Switching input
- 3. Chip carrier ground
- 4. Output
- 5. Output

YY:year  
WW:week

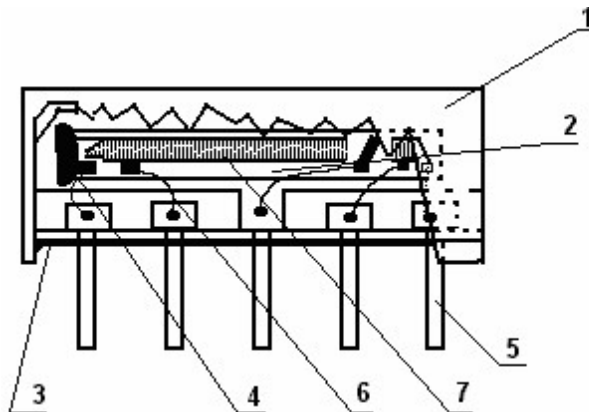

Components	Materials
1.Outer casing	PPS
2.Substrate	Lithium niobate
3.Base	Epoxy resin
4.Absorber	Epoxy resin
5.Lead	Cu alloy+Au plate
6.Bonding wire	AlSi alloy
7.Electrode	Al

**2.2. Circuit construction, measurement circuit**

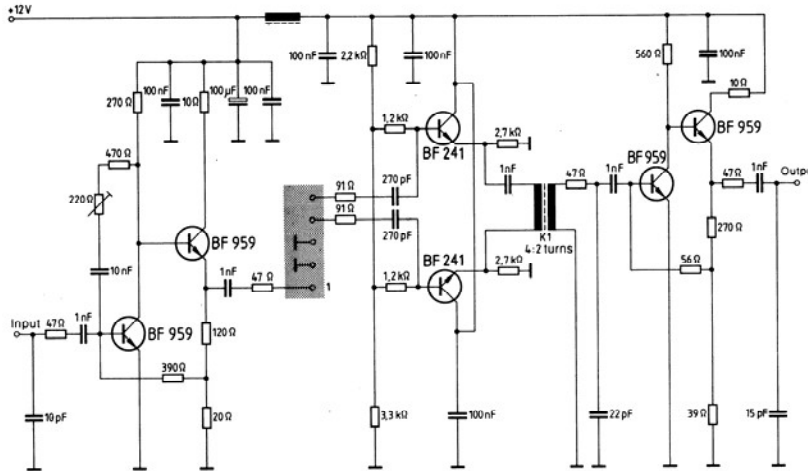

Test circuit for SIP-5 filter  
Input impedance of the symmetrical post-amplifier: 2 kΩ in parallel with 3 pF

**3.Characteristics**

Items	Conditions	Specifications
Standard atmospheric conditions	Unless otherwise specified , the standard rang of atmospheric conditions for making measurements and tests is as follows; Ambient temperature : 15°C to 35°C Relative humidity : 25% to 85% Air pressure : 86kPa to 106kPa	There shall be no damage.
Operating temperature rang	Operating temperature rang is the rang of ambient temperatures in which the filter can be operated continuously. -10°C ~ +60°C	
Storage temperature rang	Storage temperature rang is the rang of ambient temperatures at which the filter can be stored without damage. Conditions are as specified elsewhere in these specifications. -40°C ~ +70°C	
Reference temperature	+25°C	

**3.1 Maximum Rating**

<b>DC voltage</b>	<b>VDC</b>	<b>12</b>	<b>V</b>	<b>Between any terminals</b>
<b>AC voltage</b>	<b>Vpp</b>	<b>10</b>	<b>V</b>	<b>Between any terminals</b>

**3.2 Electrical Characteristics**
**Characteristics of channel 1 (switching input pin 2 connected to pin 3)**

Source impedance

$Z_s=50\ \Omega$

Load impedance

$Z_L=2k\ \Omega //3pF$

$T_A=25\ ^\circ C$

Item	Freq	min	typ	max	
<b>Insertion attenuation</b> Reference level	36.125MHz	20.8	22.3	23.8	dB
<b>Pass bandwidth</b>	B3dB	-	8.0	-	MHz
	B30dB	-	9.5	-	MHz
<b>Sidelobe</b>	25.00~30.90MHz	33.0	38.0	-	dB
	42.00~45.00MHz	31.0	35.0	-	dB
<b>Reflected wave signal suppression</b> 1.2 us ... 6.0 us after main pulse (test pulse 250 ns , carrier frequency 36.125 MHz)		-	50.0	-	dB
<b>Group delay ripple (p-p)</b> 32.32~39.93 MHz		-	60	-	ns
<b>Temperature coefficient</b>		-72			ppm/k

**Characteristics of channel 2 (switching input pin 2 connected to pin 1)**

Source impedance

$Z_s=50\ \Omega$

Load impedance

$Z_L=2k\ \Omega //3pF$

$T_A=25\ ^\circ C$

Item	Freq	min	typ	max	
<b>Insertion attenuation</b> Reference level	36.125MHz	20.8	22.3	23.8	dB
<b>Pass bandwidth</b>	B3dB	-	6.0	-	MHz
	B30dB	-	8.5	-	MHz
<b>Sidelobe</b>	25.00~31.55MHz	31.0	34.0	-	dB
	41.4~45.00MHz	31.0	34.0	-	dB
<b>Reflected wave signal suppression</b> 1.2 us ... 6.0 us after main pulse (test pulse 250 ns , carrier frequency 36.125 MHz)		-	50.0	-	dB
<b>Group delay ripple (p-p)</b> 33.59~38.65 MHz		-	60	-	ns
<b>Temperature coefficient</b>		-72			ppm/k

**3.3 Environmental Performance Characteristics**

Item	Condition	Specifications																						
High temperature	The specimen shall be store at a temperature of 80±2℃ for 96±4h. Then it shall be subjected to standard atmospheric conditions for 1h, after which measurement shall be made within 1h.	Mechanical characteristics and specifications in electrical characteristics shall be satisfied. There shall be no excessive change in appearance.																						
Low temperature	The specimen shall be store at a temperature of -20±3℃ for 96±4h. Then it shall be subjected to standard atmospheric conditions for 1h, after which measurement shall be made within 1h.																							
Humidity	The specimen shall be store at a temperature of 40±2℃ with relative humidity of 90% to 96% for 96±4h. Then it shall be subjected to standard atmospheric conditions for 1h, after which measurement shall be made within 1h.																							
Thermal shock	The specimen shall be subjected to 8 continuous cycles each as shown below. Then it shall be subjected to standard atmospheric conditions for 1h, after which measurement shall be made within 1h.																							
			<table border="1"> <thead> <tr> <th></th> <th>Temperature</th> <th>Duration</th> </tr> </thead> <tbody> <tr> <td>1</td> <td>+25 ℃=&gt;-40 ℃</td> <td>0.5h</td> </tr> <tr> <td>2</td> <td>-40 ℃</td> <td>4h</td> </tr> <tr> <td>3</td> <td>-40 ℃=&gt;+85 ℃</td> <td>2h</td> </tr> <tr> <td>4</td> <td>+85 ℃</td> <td>4h</td> </tr> <tr> <td>5</td> <td>+85 ℃=&gt;+25 ℃</td> <td>0.5h</td> </tr> <tr> <td>6</td> <td>+25 ℃</td> <td>1h</td> </tr> </tbody> </table>		Temperature	Duration	1	+25 ℃=>-40 ℃	0.5h	2	-40 ℃	4h	3	-40 ℃=>+85 ℃	2h	4	+85 ℃	4h	5	+85 ℃=>+25 ℃	0.5h	6	+25 ℃	1h
				Temperature	Duration																			
		1	+25 ℃=>-40 ℃	0.5h																				
		2	-40 ℃	4h																				
		3	-40 ℃=>+85 ℃	2h																				
		4	+85 ℃	4h																				
5	+85 ℃=>+25 ℃	0.5h																						
6	+25 ℃	1h																						
Resistance to Soldering heat	Reflow soldering method Peak: 255 ±5 ℃, 220 ±5 ℃, 40s At electrode temperature of the specimen.																							
		<p>The graph shows the temperature profile for reflow soldering. The y-axis is 'Soldering temperature' from 0 to 300. The x-axis shows time intervals: '1 to 2 min.' for pre-heating, '10s' for soldering, and '2 min. or more' for slow cooling. The pre-heating phase reaches a plateau at approximately 140°C. The soldering phase is a sharp peak reaching 255°C for 40 seconds. The slow cooling phase is a dashed line returning to room temperature.</p>																						

	<p>The specimen shall be passed through the reflow furnace with the condition shown in the above profile for 1 time.</p> <p>The specimen shall be stored at standard atmospheric conditions for 1h, after which the measurement shall be made. Test board shall be 1.6 mm thick. Base material shall be glass fabric base epoxy resin.</p>	
Solder ability	Immerse the pins melt solder at 260°C+5/-0°C for 5 sec.	More then 95% of total area of the pins should be covered with solder

### 3.4 Mechanical Test

Items	Conditions	Specifications
Vibration	600-3300rpm amplitude 1.5mm 3 directions 2 H each	There shall be no damage.
Drop	On maple plate from 1 m high 3 times	
Lead pull	Pull with 1 kg force for 30 seconds	
Lead bend	90° bending with 500g weigh 2 times	

### 3.5 Voltage Discharge Test

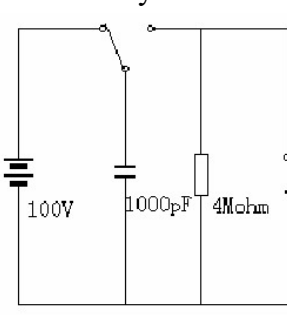
Item	Condition	Specifications
Surge	<p>Between any two electrode</p> 	There shall be no damage

3.6 Frequency response of channel 1:

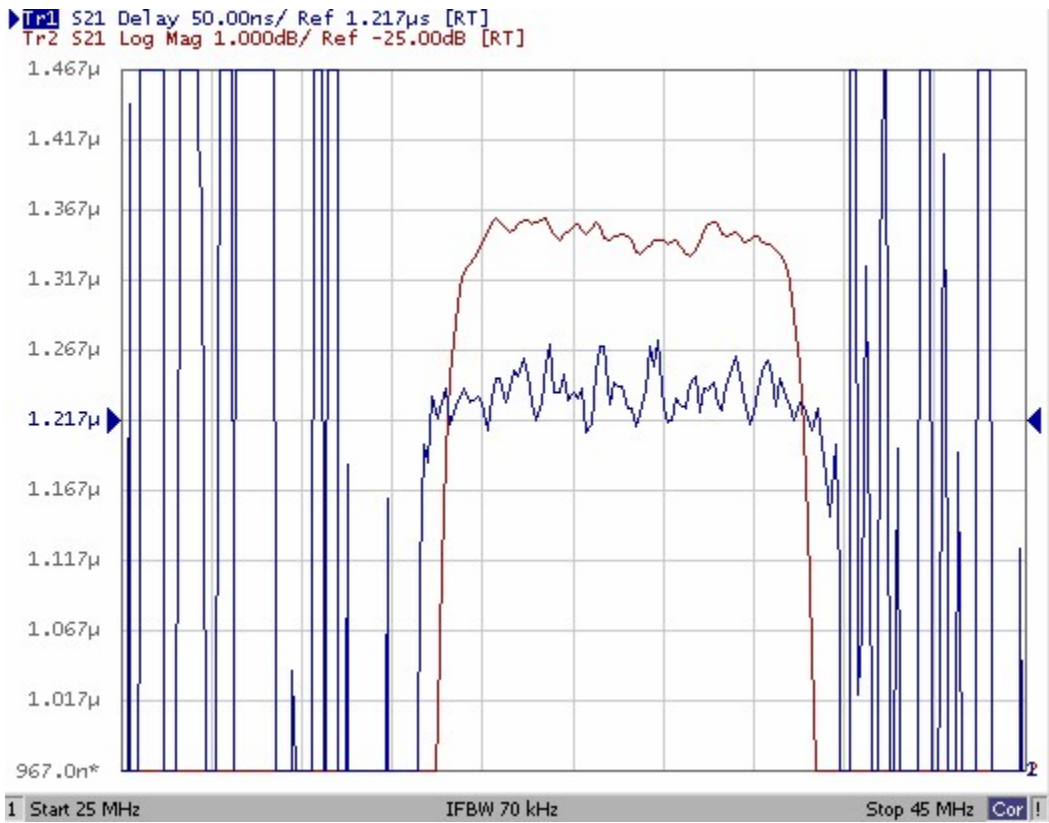
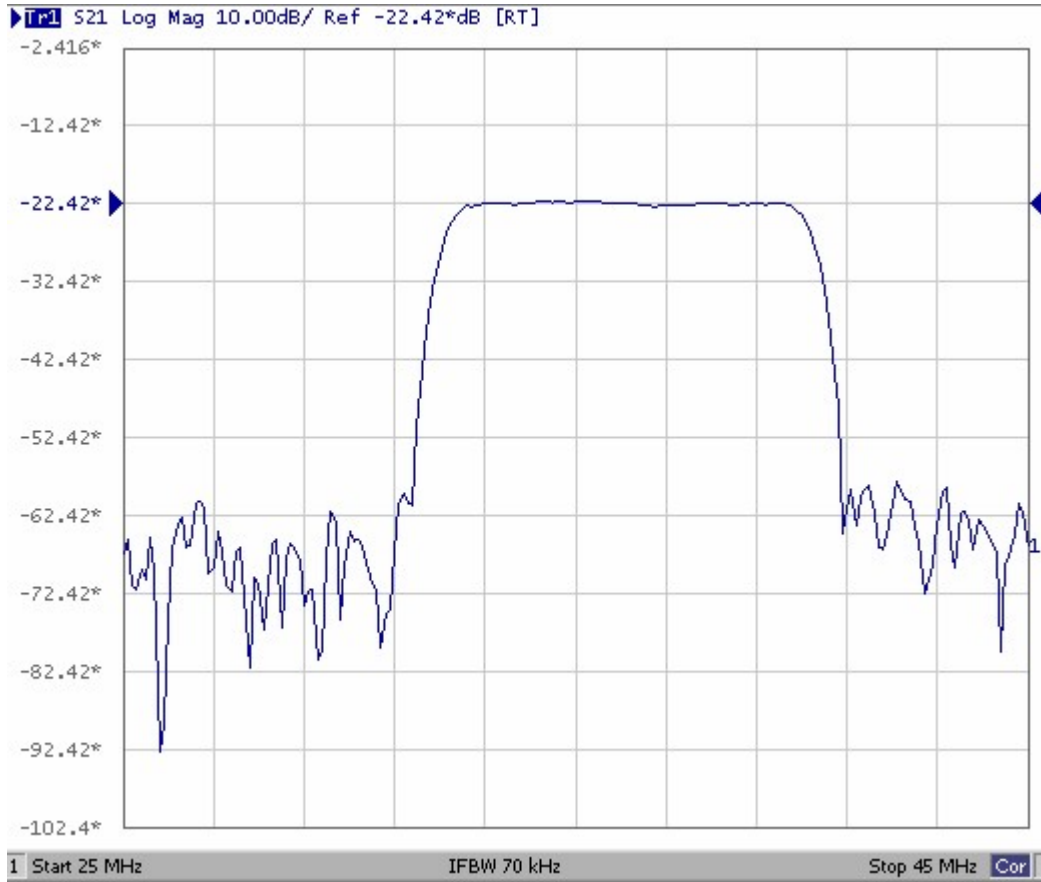



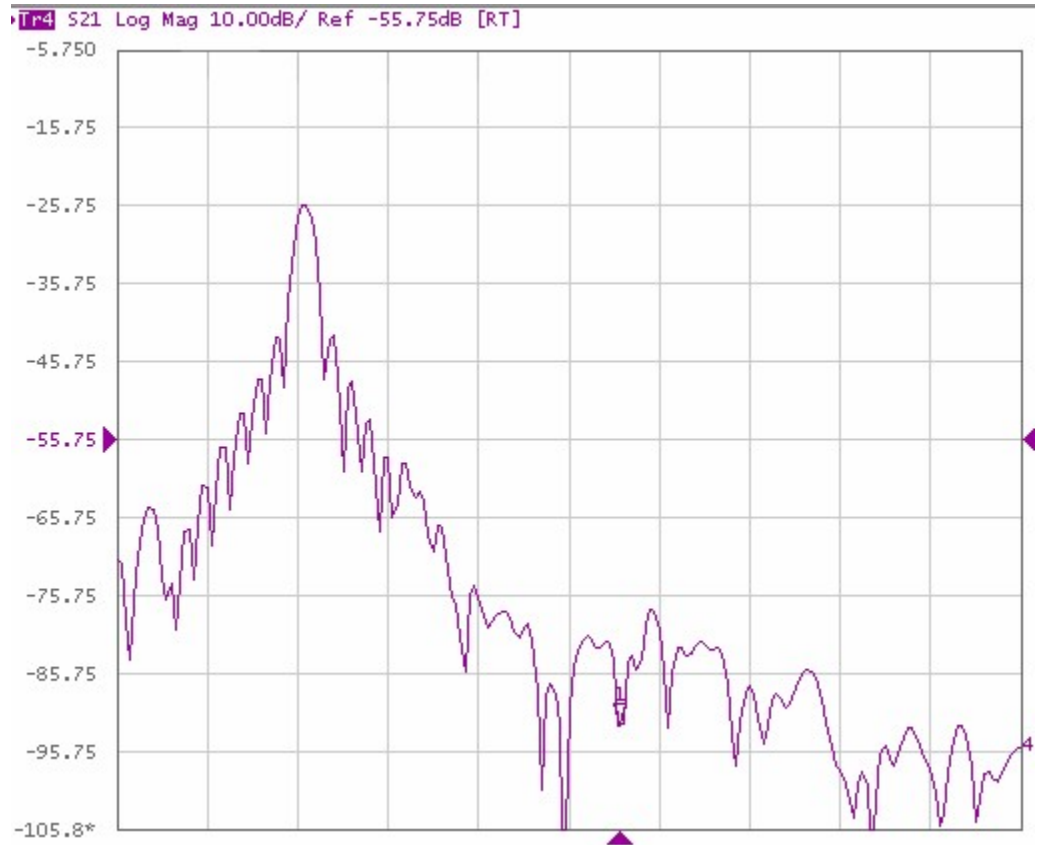
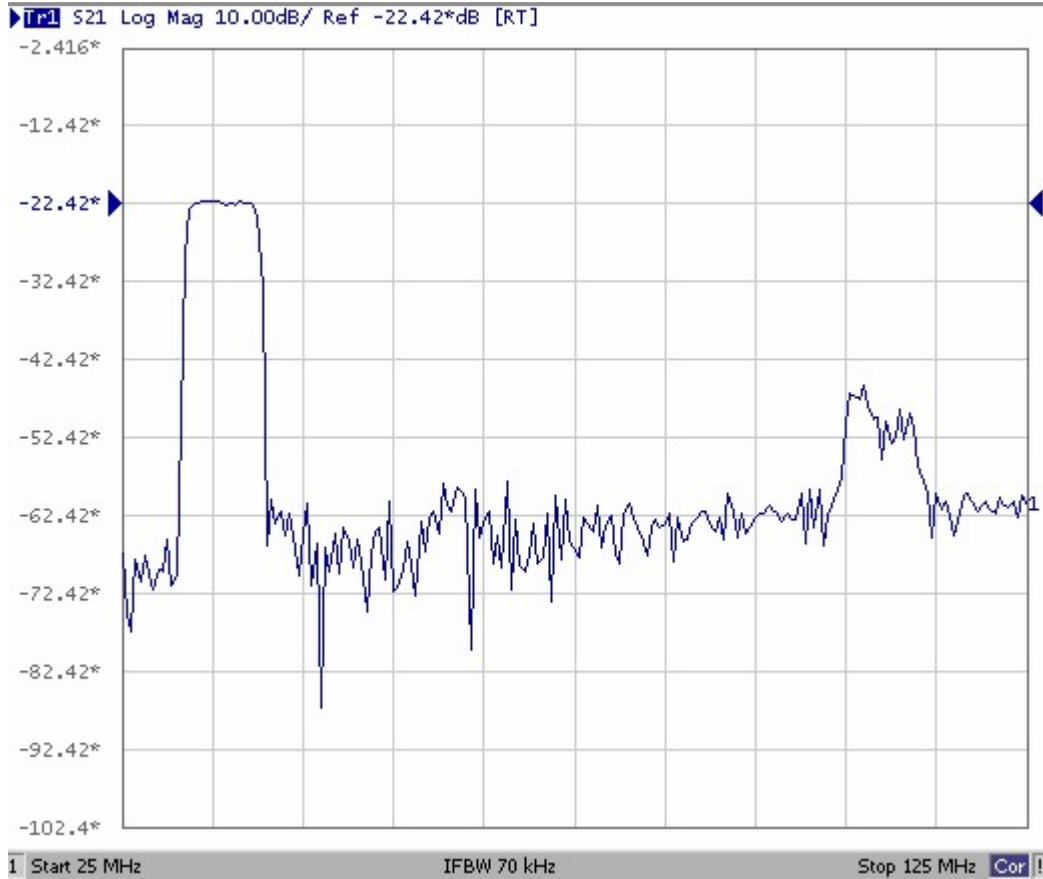

Frequency response of channel 2:

