

REVISIONS				
REV	DATE	BY	APP'D	DESCRIPTION
E	3-6-17	CT	DM	REV PER ECO 17-002961

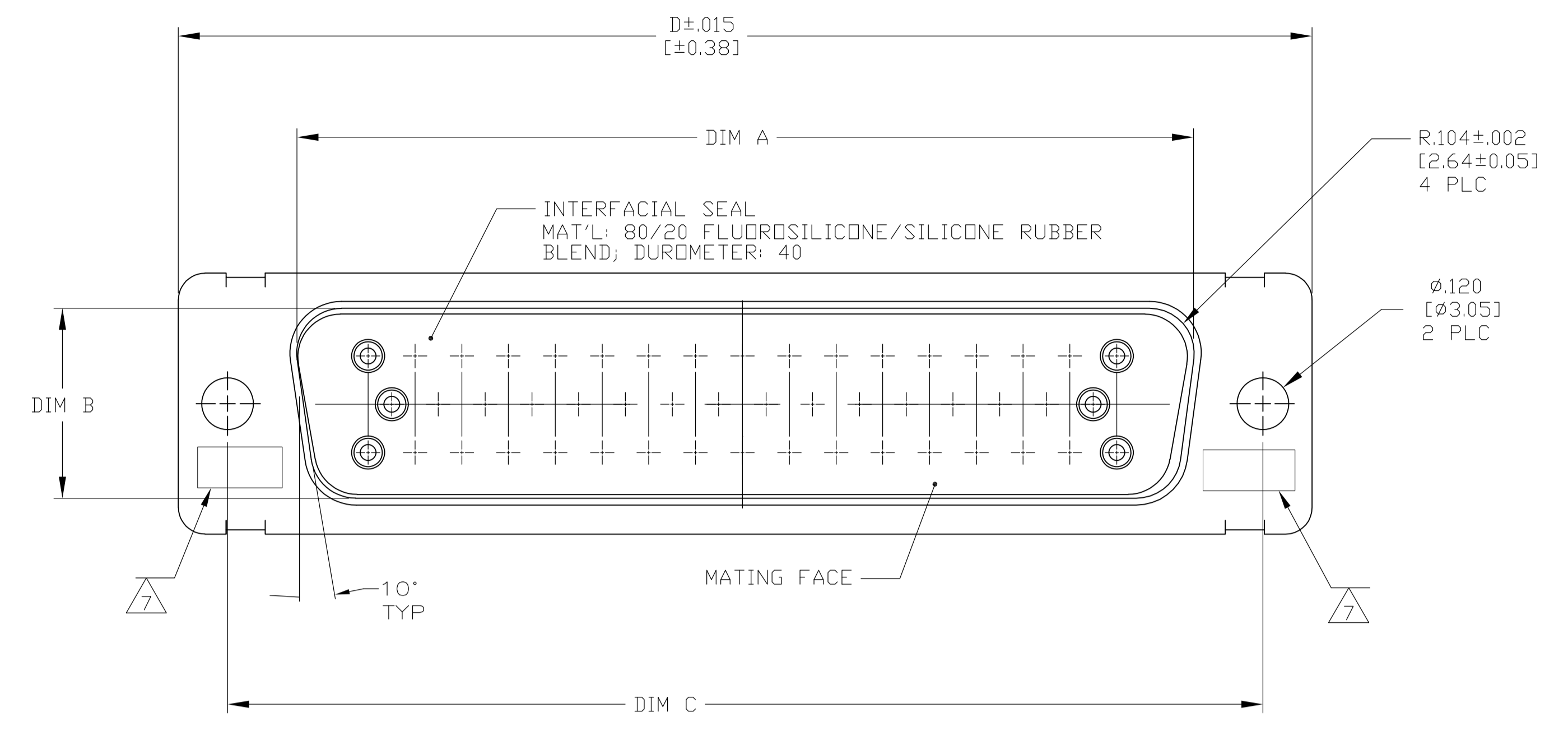

1. MARKED WITH .047 [1.19] HIGH CHARACTERS. FAR SIDE REFERS TO WIDE SIDE OF KEYSTONE, NEAR SIDE REFERS TO NARROW SIDE OF KEYSTONE.
2. THIS ASSEMBLY IS DESIGNED TO CONFORM TO THE LATEST ISSUE OF MIL-DTL-24308.
3. MAXIMUM WIRE INSULATION USED WITH THIS CONNECTOR IS .072 [1.83] DIAMETER WITH GROMMET
4. METAL RETENTION CLIPS ARE INCLUDED IN INSERTS.
5. THIS PLUG WILL MATE WITH ANY RECEPTACLE CONNECTOR WITH THE SAME INSERT ARRANGEMENT.
6. CONTACTS ARE PACKAGED SEPARATELY AND SHIPPED WITH CONNECTOR. (2157480-1 THRU -5 ONLY)
7. UL/CSA DESIGNATION STAMPED IN THIS AREA.
8. EPOXY IS APPLIED BETWEEN FRONT & REAR SHELLS AND INSERT.
9. FOR CONTACT CRIMPING AND CONTACT INSTALLATION AND REMOVAL REFER TO TE I.S. 408-7516.
10. INTERFACIAL SEAL IS BONDED TO FRONT INSERT.

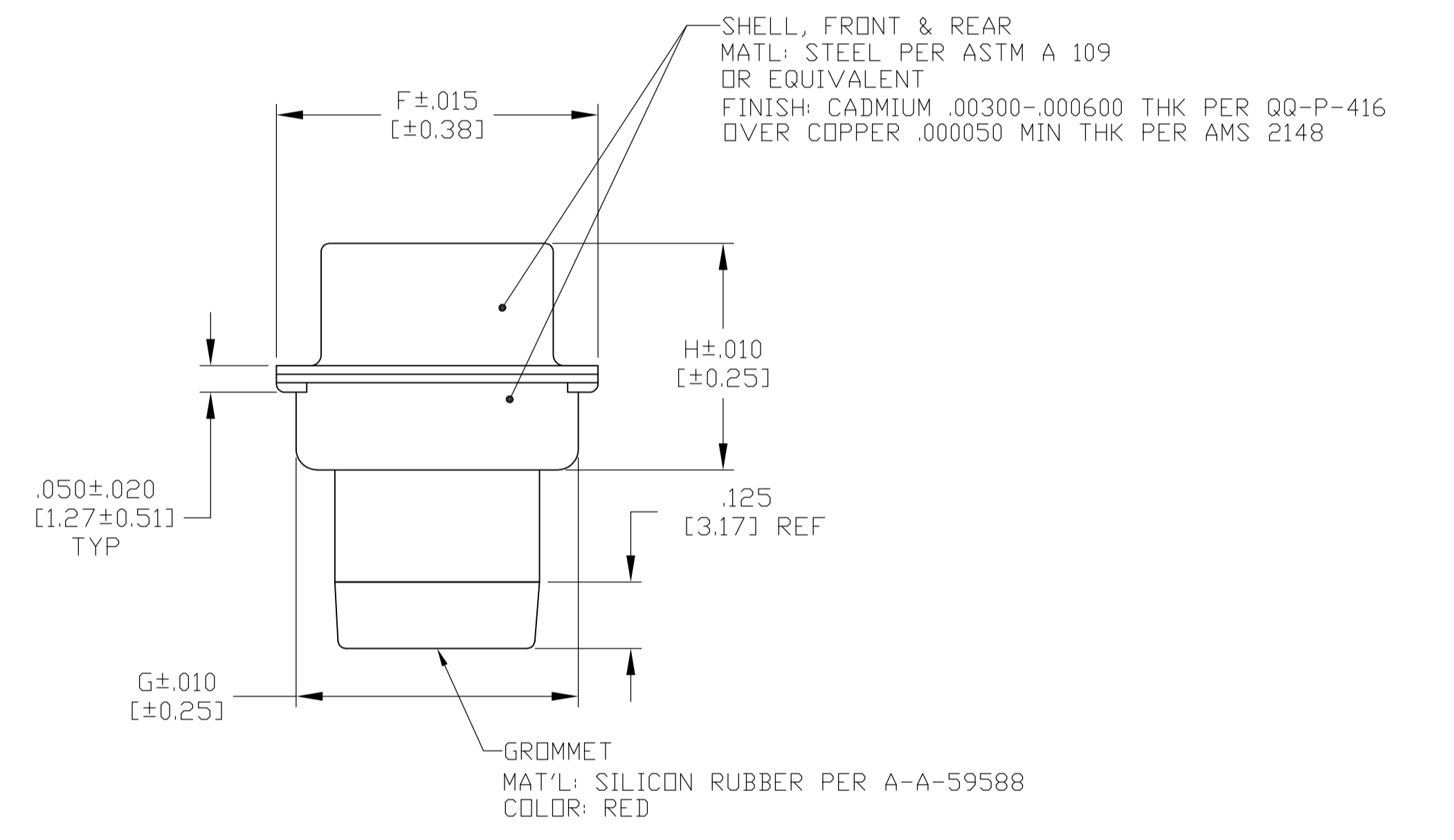
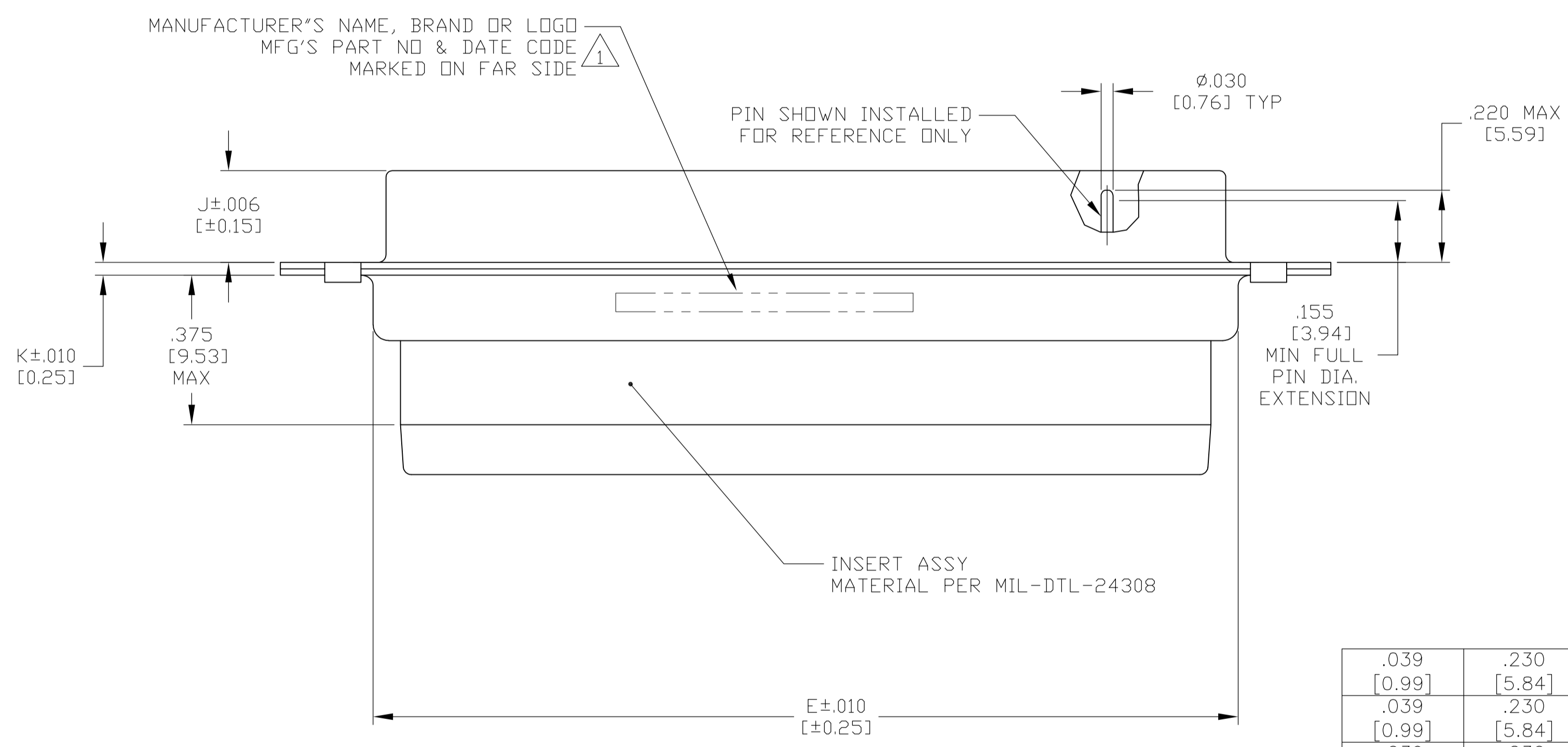
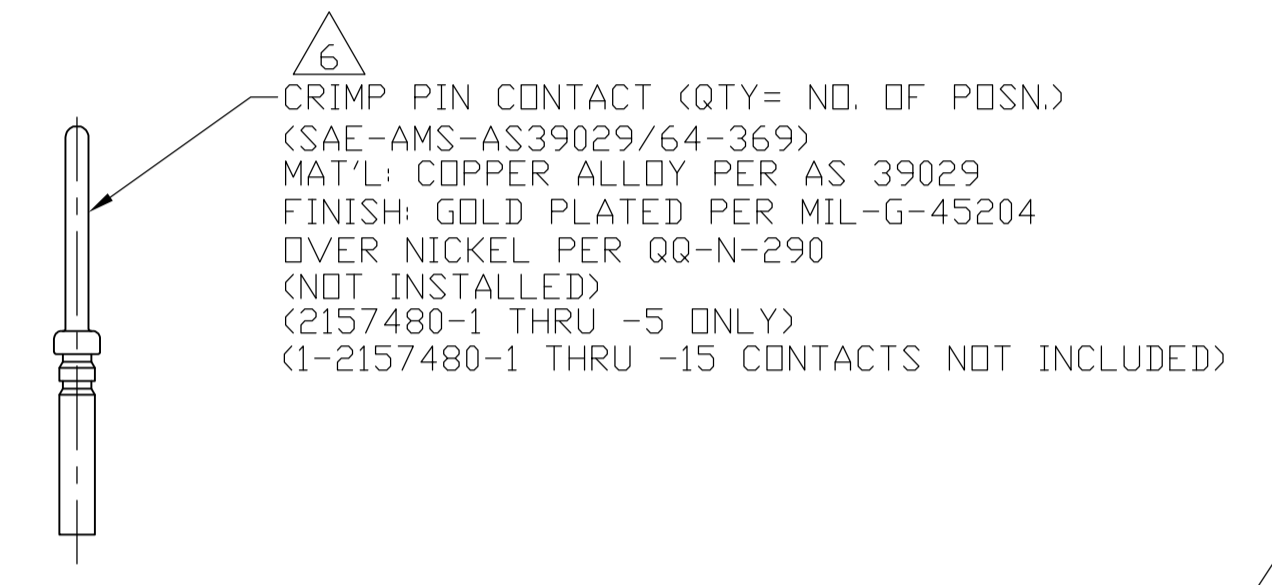

.039	.230	.426	.534	.605	2.178	2.635	2.406	.441	2.079	50	1-2157480-5
[0.99]	[5.84]	[10.82]	[13.56]	[15.37]	[55.32]	[66.93]	[61.11]	[11.20]	[52.81]		
.039	.230	.426	.422	.494	2.272	2.729	2.500	.329	2.182	37	1-2157480-4
[0.99]	[5.84]	[10.82]	[10.72]	[12.55]	[57.71]	[69.32]	[63.50]	[8.36]	[55.42]		
.039	.230	.426	.422	.494	1.625	2.088	1.852	.329	1.534	25	1-2157480-3
[0.99]	[5.84]	[10.82]	[10.72]	[12.55]	[41.27]	[53.03]	[47.04]	[8.36]	[39.96]		
.030	.235	.422	.422	.494	1.083	1.541	1.312	.329	.994	15	1-2157480-2
[0.76]	[5.97]	[10.72]	[10.72]	[12.55]	[27.51]	[39.14]	[33.32]	[8.36]	[25.25]		
.030	.235	.422	.422	.494	.759	1.213	.984	.329	.666	9	1-2157480-1
[0.76]	[5.97]	[10.72]	[10.72]	[12.55]	[19.28]	[30.81]	[24.99]	[8.36]	[16.92]		
.039	.230	.426	.534	.605	2.178	2.635	2.406	.441	2.079	50	2157480-5
[0.99]	[5.84]	[10.82]	[13.56]	[15.37]	[55.32]	[66.93]	[61.11]	[11.20]	[52.81]		
.039	.230	.426	.422	.494	2.272	2.729	2.500	.329	2.182	37	2157480-4
[0.99]	[5.84]	[10.82]	[10.72]	[12.55]	[57.71]	[69.32]	[63.50]	[8.36]	[55.42]		
.039	.230	.426	.422	.494	1.625	2.088	1.852	.329	1.534	25	2157480-3
[0.99]	[5.84]	[10.82]	[10.72]	[12.55]	[41.27]	[53.03]	[47.04]	[8.36]	[39.96]		
.030	.235	.422	.422	.494	1.083	1.541	1.312	.329	.994	15	2157480-2
[0.76]	[5.97]	[10.72]	[10.72]	[12.55]	[27.51]	[39.14]	[33.32]	[8.36]	[25.25]		
.030	.235	.422	.422	.494	.759	1.213	.984	.329	.666	9	2157480-1
[0.76]	[5.97]	[10.72]	[10.72]	[12.55]	[19.28]	[30.81]	[24.99]	[8.36]	[16.92]		
DIM K	DIM J	DIM H	DIM G	DIM F	DIM E	DIM D	DIM C	DIM B	DIM A	NO. OF POSITIONS	PART NUMBER

PRELIMINARY PART NO.
PRELIMINARY PART NO.

THIS DRAWING IS A CONTROLLED DOCUMENT.

DIMENSIONS: INCHES [mm]	TOLERANCES UNLESS OTHERWISE SPECIFIED:	DIN C.C. THOMAS 10-14-14	10-14-14
0 PLC ± -	1 PLC ± -	C.D. THOMAS 10-14-14	10-14-14
2 PLC ± -	3 PLC ± .005 [0.13]	C.D. THOMAS 10-14-14	10-14-14
4 PLC ± -	ANGLES ± 1°	C.D. THOMAS 10-14-14	10-14-14

MATERIAL: SEE CALLOUTS FINISH: SEE CALLOUTS WEIGHT: 0.000000 A1 00779 C=2157480

CUSTOMER DRAWING SCALE: 4:1 SHEET 1 OF 1 REV E

STE TE Connectivity

PLUG ASSY, SIZE 1-5, IP67 SERIES 109, AMPLIMITE WITH IF SEAL AND GROMMET