

> MECHANICAL COMPONENTS ASSEMBLY <

No.	Component Description	Qty.	Part Number
1	Universal Bracket moulding	1	OND-1900101-**
2	Threaded insert	2	OND-1900102-01

NOTE: ** The individual moulding colour will match the assembly colour suffix.

NO.	REVISION	DATE SIGNED
△	P/N Release	20.05.16 TM

"Break-out" Locking clip

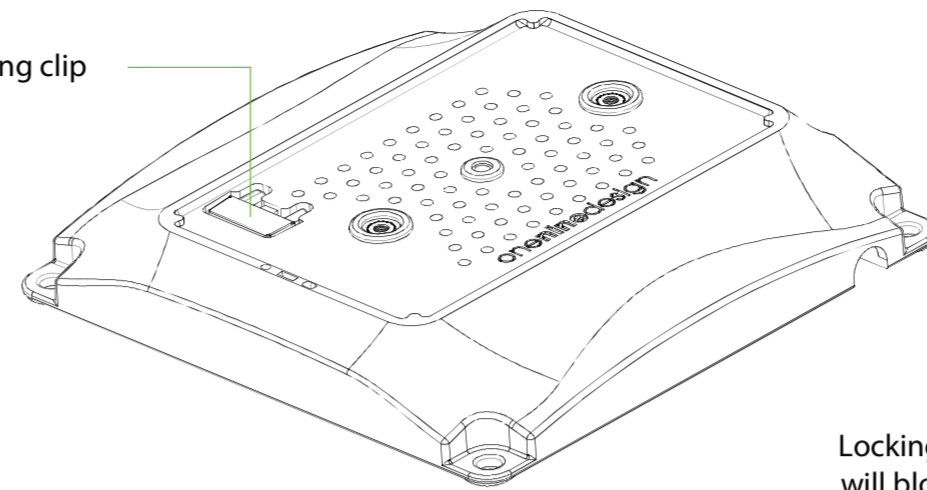

Locking clip fitted here will block access to the SD card
ASM-1900036-** Only

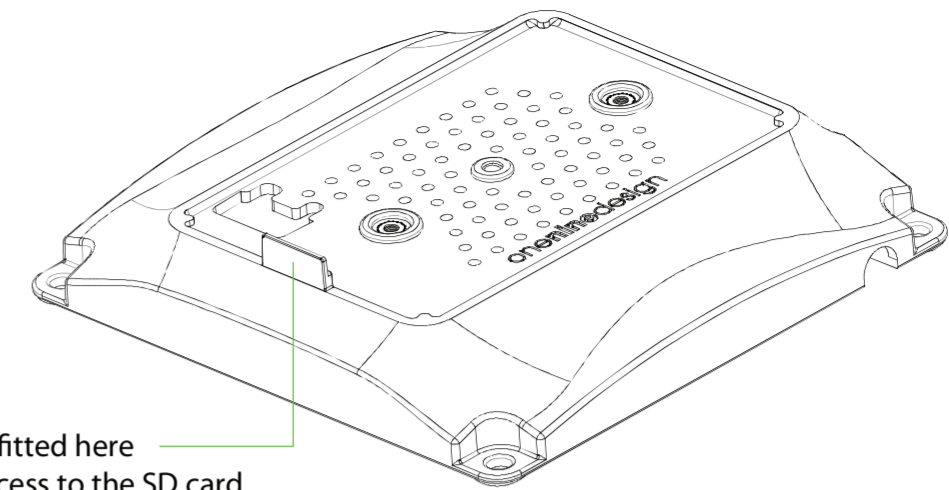

Space for 2.5" HDD
(Not supplied with this Bracket)

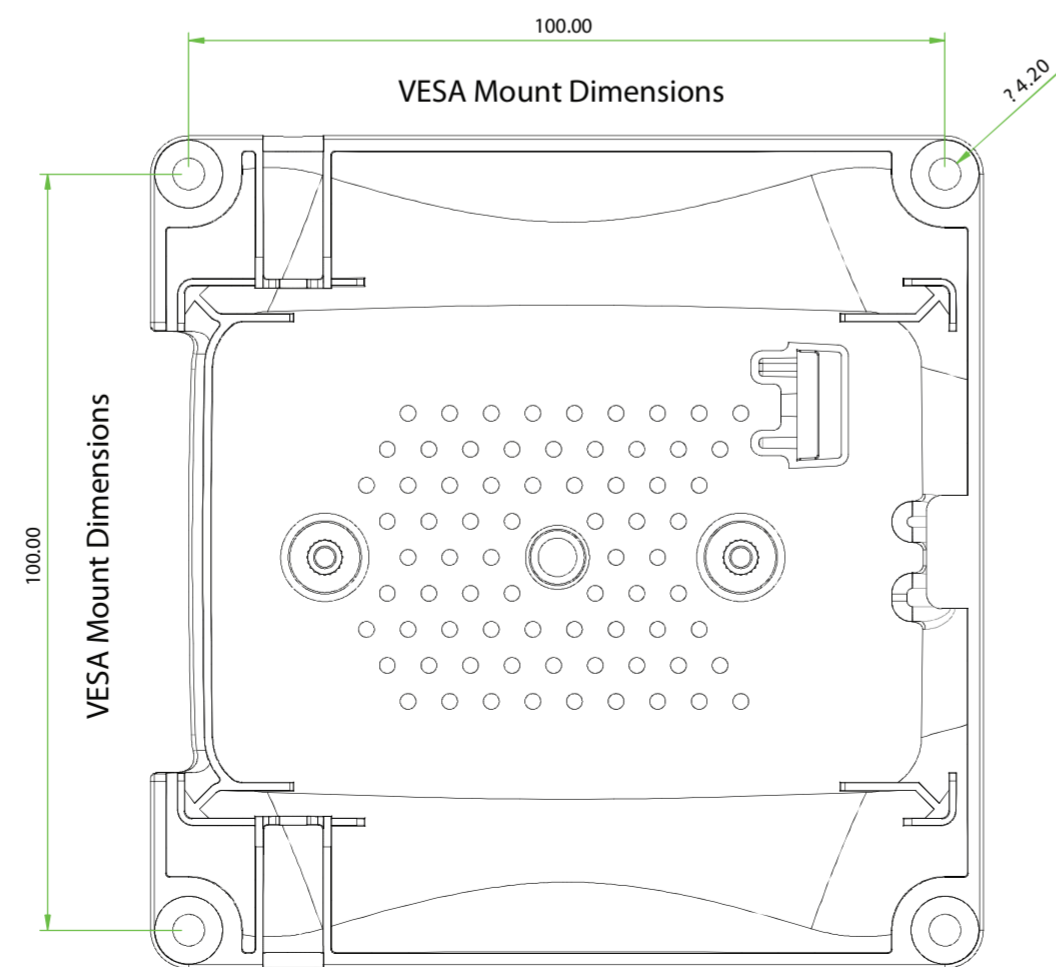
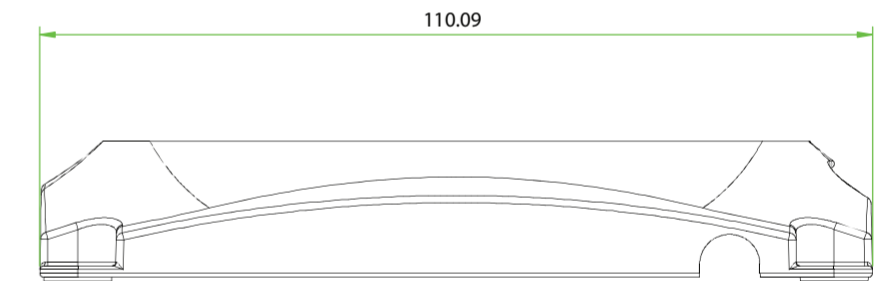
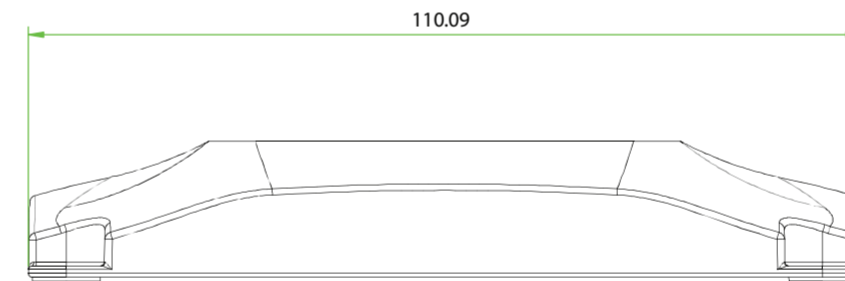
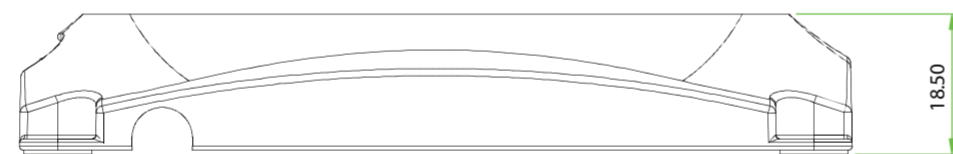
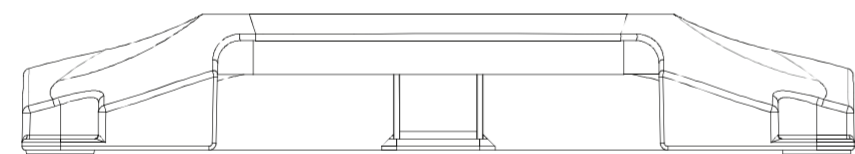
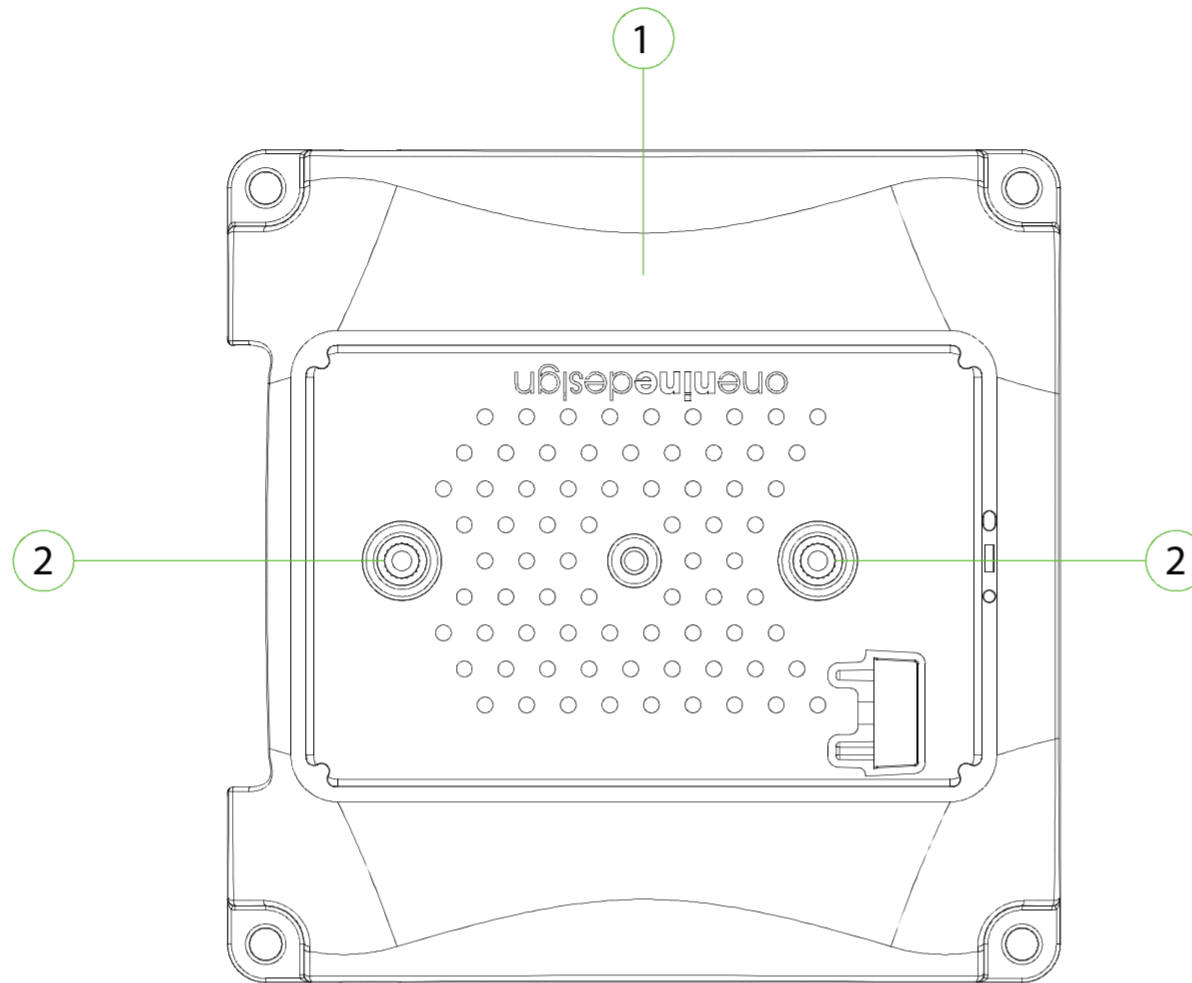
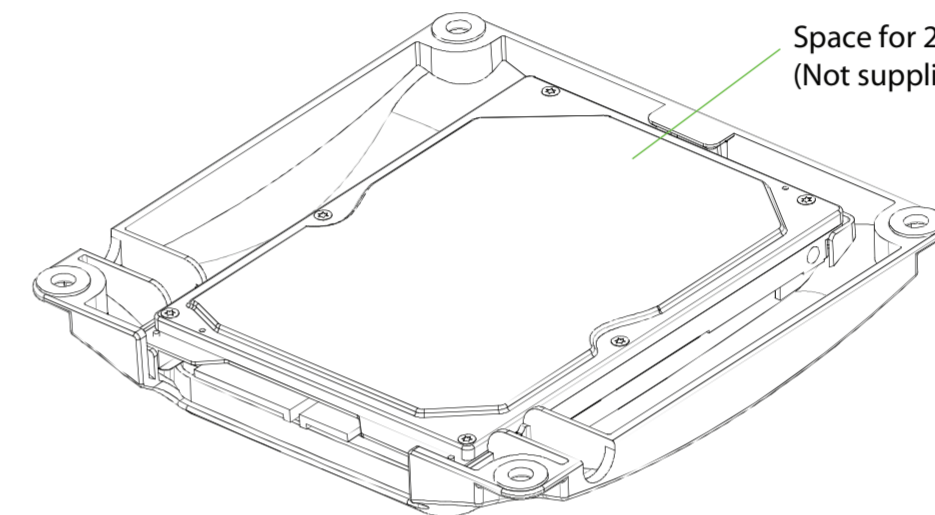

NOTES

- GENERAL DRAFT ANGLE SHALL BE 1° UNLESS OTHERWISE STATED
- PRODUCT SHOULD NOT HAVE WELD LINE AND/OR FLOW MARK.
- PRODUCT SHOULD NOT HAVE STRESS/SINK MARKS.
- HEIGHT OF BURRS SHOULD BE LESS THAN 0.1MM.
- THE PART NUMBER SHOULD BE EXPRESSED BY CONVEX LETTERS, THE TYPE OF WHICH IS OPTIONAL.
- GATES SHOULD BE REMOVED COMPLETELY.
- SECTIONS SHOWN ARE TRUE AT SECTION LINE, VARIOUS DETAILS THAT APPEAR BEHIND SECTION LINE ARE OMITTED AND/OR INCLUDED TO CLARIFY THE DRAWING.
- VENDOR INSPECTION REPORTS MUST ACCOMPANY SAMPLES SUBMITTED FOR APPROVAL.
- PARTS MUST BE SUITABLY PACKED TO AVOID DAMAGE IN SHIPMENT.

Suffix	Component Description	Comment
-01	Case Assembly - Colour = CLEAR	
-11	Case Assembly - Colour = WHITE	
-21	Case Assembly - Colour = BLACK	

REFER TO 3D CAD DATA FOR TOOL MANUFACTURE

RoHS Compliant: Parts on this document must comply with the requirements and procedures specified in the RoHS compliant handbook - www.rohs.gov.uk

GENERAL TOLERANCE	
DIM'N	TOL. ±
0 → 6	0.08
7 → 30	0.1
31 → 120	0.2
121 → 300	0.3
301 → 600	0.4
601 → 1200	0.5

NO.	PART NO.	DESCRIPTION	MODEL NO.	MATERIAL	FINISH	QTY
1	ASM-1900048- See Suffix table	UNIVERSAL BRACKET	RASPBERRY Pi	ABS UL94HB	Polished areas Textured areas	
				ALL DIMENSIONS IN mm UNLESS OTHERWISE STATED	SHEET 1 OF 1	
DRAWN TM 20.05.16		CHECKED TM 20.05.16	APPROVED	SCALE 1:1	CAD DATA:	

THIRD A2