

# Accessories

## Mounting accessories

### Torque support and spring washer

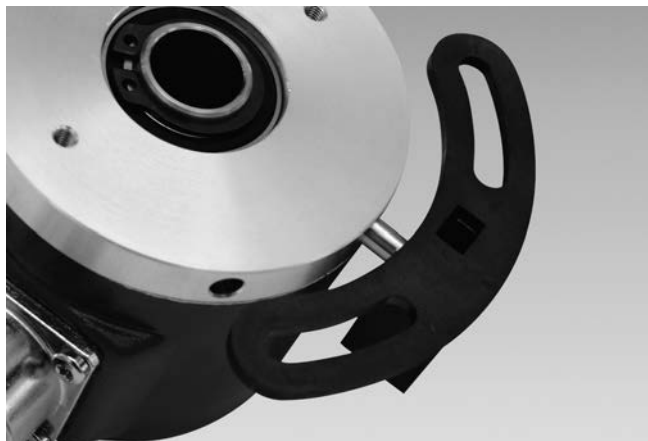

#### Features

- Easy and cost-effective mounting
- For applications with low acceleration

#### Description

Push encoder onto drive shaft. Insert torque pin into the torque support provided by customer.

#### Part number

10140347 Torque support and spring washer for encoders with 9.5 mm pin (Z 119.024)

#### Scope of delivery

Included: spring coupling, three screws M4 x 10 with spring washer and two lock washers

#### Suitable for

G0333, G0A2H, G0M2H, G0P5H, GBA2S, GBAMS, GBMMS, GBP5H, GBP5S, GI330, GI331, GI332, GI333, GXA2S, GXAMS, GXM2S, GXM7S, GXMMS, GXP5S

#### Dimensions

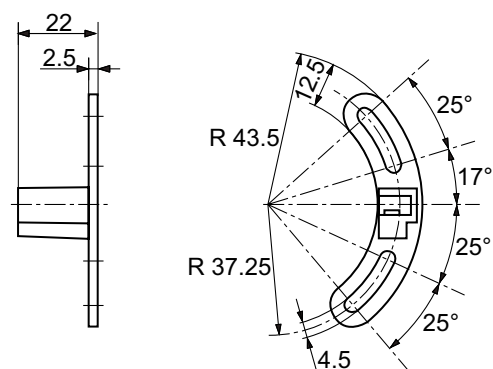

#### Assembly drawing

