

Brushless Flat DC-Micromotors

with integrated Speed Controller

3,7 mNm

Series 2610 ... B SC

	2610 T	006 B	012 B	SC
1 Nominal voltage	U _N	6	12	Volt
2 Terminal resistance, phase-phase	R	7,0	28,2	Ω
3 Output power ¹⁾	P _{2 max.}	1,92	1,91	W
4 Efficiency	η _{max.}	78	78	%
5 No-load speed	n ₀	6 200	6 200	rpm
6 No-load current	I ₀	0,012	0,006	A
7 Stall torque	M _H	7,73	7,68	mNm
8 Friction torque, static	C ₀	0,025	0,025	mNm
9 Friction torque, dynamic	C _v	1,35 · 10 ⁻⁵	1,35 · 10 ⁻⁵	mNm/rpm
10 Speed constant	k _n	1 055	528	rpm/V
11 Back-EMF constant	k _E	0,948	1,895	mV/rpm
12 Torque constant	k _M	9,05	18,1	mNm/A
13 Current constant	k _I	0,111	0,055	A/mNm
14 Slope of n-M curve	Δn/ΔM	816	822	rpm/mNm
15 Terminal inductance, phase-phase	L	480	1 940	μH
16 Mechanical time constant	τ _m	69	70	ms
17 Rotor inertia	J	8,1	8,1	gcm ²
18 Angular acceleration	α _{max.}	9,5	9,5	· 10 ³ rad/s ²
19 Thermal resistance	R _{th 1} / R _{th 2}	33 / 27		K/W
20 Thermal time constant	τ _{w1} / τ _{w2}	20 / 230		s
21 Operating temperature range		-25 ... +80		°C
22 Shaft bearings		ball bearing, preloaded		
23 Shaft load max.:				
– radial at 3 000/7 000 rpm (3 mm from mounting flange)		4,0 / 3,5		N
– axial at 3 000/7 000 rpm (push-on only)		3,5 / 3,4		N
– axial at standstill (push-on only)		17,5		N
24 Shaft play:				
– radial	≤	0,015		mm
– axial	=	0		mm
25 Housing material		plastic		
26 Weight		20,1		g
27 Direction of rotation		electronically reversible		
28 Number of pole pairs		2		
Recommended values - mathematically independent of each other				
29 Speed up to	n _{e max.}	7 000	7 000	rpm
30 Torque up to ^{1) 2)}	M _{e max.}	3,14 / 3,72	3,13 / 3,70	mNm
31 Current up to ^{1) 2)}	I _{e max.}	0,40 / 0,47	0,20 / 0,24	A

¹⁾ at 5 000 rpm

²⁾ thermal resistance R_{th 2} not reduced / thermal resistance R_{th 2} by 55% reduced

Note:

The diagram indicates the recommended speed in relation to the available torque at the output shaft for a given ambient temperature of 22°C.

The diagram shows the motor in a completely insulated as well as thermally coupled condition (R_{th 2} 55% reduced).

The area of the curve is defined by the maximum allowable supply voltage of the integrated speed controller as well as the control performance characteristics.

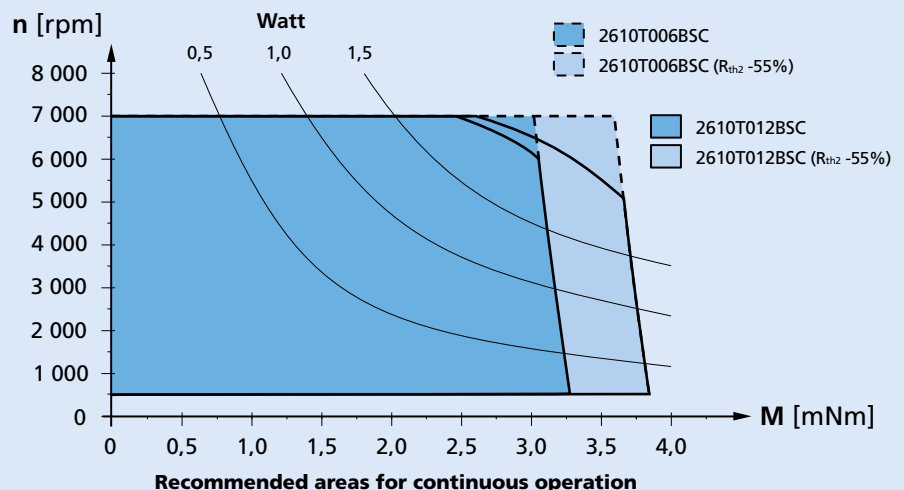

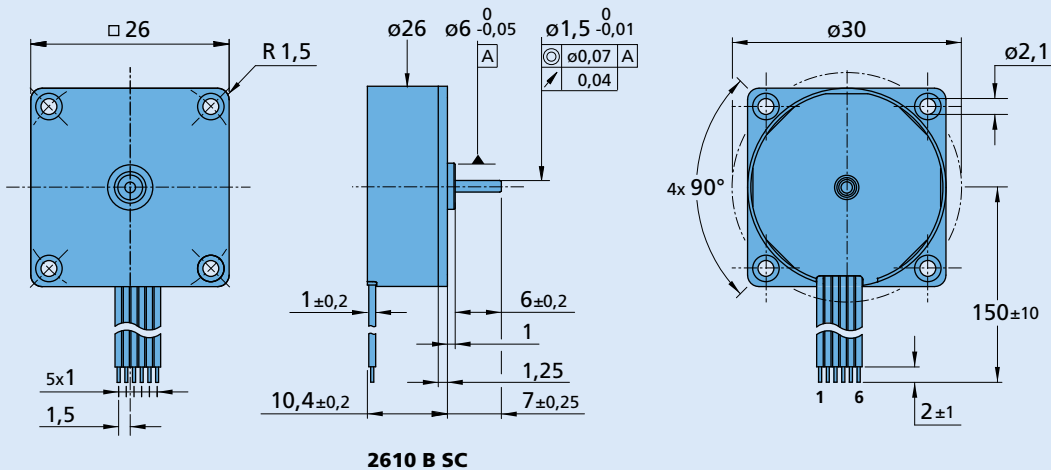
2610 T ... B SC

Cable
Jacket Material: PVC
8 conductors, AWG 28
grid 1,0 mm
wires tinned

Note:
Hallsensors digital

Connection

No.	Function
1	U _P
2	U _{mot}
3	GND
4	U _{nsoll}
5	DIR
6	FG

Speed Controller

PWM switching frequency	96	kHz
Efficiency	95	%
Max. continuous output current ¹⁾	0,8	A
Max. peak output current	1,6	A
Total standby current	0,020	A
Speed range:		
– standard » Hall sensors (digital)	500 ... 60 000 ²⁾	rpm
Scanning range	500	µs

¹⁾ at 22°C ambient temperature and max. 60°C motor temperature respectively

²⁾ speed depend on motor operating voltage

Connection information

Connection 1 "U_P":	power supply electronic	U _P = 4 ... 18 V
Connection 2 "U_{mot}":	power supply electronic coil	U _{mot} = 1,7 ... 18 V
Connection 3 "GND":	ground	ground
Connection 4 "U_{nsoll}":		
– analog input	input voltage input resistance set speed value	U _{in} = 0 ... 10V (max. U _P) R _{in} ≥ 8 kΩ per 1V » 1 000 rpm U _{in} < 0,15V » motor stops U _{in} > 0,3V » motor starts
Connection 5 "DIR":		
– digital input	direction of rotation input resistance	to ground or level < 0,5V » counterclockwise open or level > 3V » clockwise (max. U _P) R _{in} ≥ 10 kΩ
Connection 6 "FG":		
– digital output	frequency output	with max. U _P » I _{max} = 15 mA; open collector with 22 kΩ pull-up resistor 6 lines per revolution

Features

In this variant, the brushless DC-Micromotors have an integrated Speed Controller. The motor is commutated using Hall sensors integrated into the motor. Speed control is via a PI regulator. The Speed Controller has a current limiting device which limits the maximum motor current if the thermal load is too high. Twice the continuous current is possible over a short time.

Using the "FAULHABER Motion Manager" software, the customer can modify the Speed Controller to special conditions of use.

The following parameters can be changed: current limit and regulator parameters.

Full product description

Examples:
2610T006B SC
2610T012B SC

Option

connector variants
(Option no. 4257)
AWG 28 / PVC ribbon cable with connector Picoblade

