



NUMBER GS-20-0327	TYPE Application Specification		
TITLE Mini-SAS HD External Application Specification		PAGE 1 of 18	REVISION C
		AUTHORIZED BY M. Scholeno	DATE 2012-6-28
CLASSIFICATION UNRESTRICTED			

TABLE OF CONTENTS

1.0	OBJECTIVE.....	3
2.0	SCOPE	3
3.0	DRAWINGS AND APPLICABLE DOCUMENTS	3
4.0	GENERAL	3
4.1	PRODUCT DESCRIPTION	3
4.2	PRODUCT CONFIGURATIONS	4
4.3	KEYING FEATURES	5
4.3.1	MATING OF THE PLUG	5
4.4	PIN DESIGNATIONS AND USAGE	6
5.0	PCB REQUIREMENTS	6
5.1	BOARD LAYOUT	6
5.2	BOARD THICKNESS	6
5.3	CONNECTOR TO CONNECTOR SPACING	6
5.4	BACK DRILLING	8
5.5	KEEP-OUT ZONES FOR APPLICATION AND REMOVAL TOOLING:	8
5.6	BREAKOUT RECOMMENDATION:	9
6.0	APPLICATION TOOLING	11
6.1	CONNECTOR INSERTION TOOLING.....	11
6.2	INSERTION PRESSES	11
7.0	RECOMMENDED INSERTION FORCES	11
8.0	APPLICATION PROCEDURE.....	12
9.0	POST-APPLICATION INSPECTION PROCEDURES	14
10.0	MOUNTING SCREWS	15

PDS: Rev :C STATUS: Released Printed: Jul 07, 2012

This document is the property of and embodies CONFIDENTIAL and PROPRIETARY information of FCI. No part of the information shown in this document may be used in any way or disclosed to others without the written consent of FCI. Copyright FCI.

NUMBER GS-20-0327	TYPE Application Specification		
TITLE Mini-SAS HD External Application Specification		PAGE 2 of 18	REVISION C
		AUTHORIZED BY M. Scholeno	DATE 2012-6-28
		CLASSIFICATION UNRESTRICTED	

11.0	PANEL MOUNTING.....	16
11.1	PANEL OPENING.....	17
11.2	PANEL THICKNESS	17
12.0	REPAIR TOOLING.....	17
13.0	RECORD RETENTION.....	18

NUMBER GS-20-0327	TYPE Application Specification		
TITLE Mini-SAS HD External Application Specification		PAGE 3 of 18	REVISION C
		AUTHORIZED BY M. Scholeno	DATE 2012-6-28
CLASSIFICATION UNRESTRICTED			

1.0 OBJECTIVE

This specification provides information and requirements regarding customer application of Mini-SAS HD board connector for external applications. This specification is intended to provide general guidance for application process development. It is recognized that no single application process will work under all customer scenarios and that customers will develop their own application processes to meet their needs. However, if these application processes differ greatly from the one recommended, FCI cannot guarantee results.

2.0 SCOPE

This specification provides information and requirements regarding customer application of the external Mini-SAS HD board connector with press-fit termination.

3.0 DRAWINGS AND APPLICABLE DOCUMENTS

- FCI PRODUCT SPECIFICATION: GS-12-651
- FCI PRODUCT CUSTOMER DRAWINGS: 10112626, 10112627, 10112628
- INDUSTRY SPECIFICATION: SFF-8644

FCI product drawings and specifications can be obtained by accessing the FCI website www.fci.com or contacting FCI Technical Service. In the event of a conflict between this application specification and the drawing, the drawing will take precedence. Customers are advised to refer to the latest revision level of the applicable documents for appropriate details.

4.0 GENERAL

This document is meant to be an application guide. If there is a conflict between the product drawings and specifications, the drawings take precedence.

4.1 PRODUCT DESCRIPTION

The Mini-SAS HD external board connector is a high density, high speed board connector designed to mate with a corresponding Mini-SAS HD external cable assembly. The connector is offered in right angle orientation and features compliant press-fit tails for a reliable electrical interconnection between the connector and the printed circuit board (PCB). The connector is housed within a cage assembly for EMI (electromagnetic interference) suppression. The cage also utilizes compliant press-fit tails for connection to the PCB and spring fingers that make contact with the bezel opening for ground termination. The connector and cage are supplied as one unit for easy one step installation to the PCB. The cage is threaded for screw attachment to the PCB. This provides strain relief and additional retention to the board. The cage also has a primary and secondary blocking key to ensure proper mating with the cable assembly. Each connector contains two rows of eighteen contacts for a total of thirty six contact positions. Twelve of the thirty six contacts are dedicated as ground terminals and the remaining twenty four contacts can be used for signal contacts. Connectors can be ganged together within a single assembly if more contact positions are needed. See section 4.2 for a listing of the available product sizes.

NUMBER GS-20-0327	TYPE Application Specification		
TITLE Mini-SAS HD External Application Specification		PAGE 4 of 18	REVISION C
		AUTHORIZED BY M. Scholeno	DATE 2012-6-28
CLASSIFICATION UNRESTRICTED			

4.2 PRODUCT CONFIGURATIONS

See Table 1 and Figure 1 for the listing and views of the available product configurations.

Product Configuration	Product Orientation	Number of contacts Per Assembly		
		Total	Signal	Ground
1 X 1	Right Angle	36	24	12
1 X 2	Right Angle	72	48	24
1 X 4	Right Angle	144	96	48

Table 1: Available Product configurations

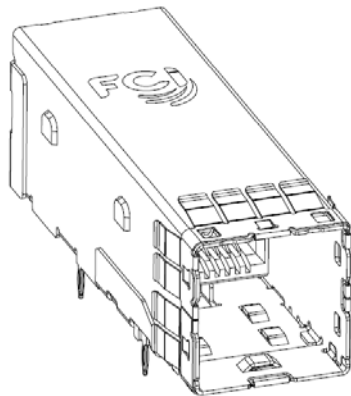

1X1 Configuration

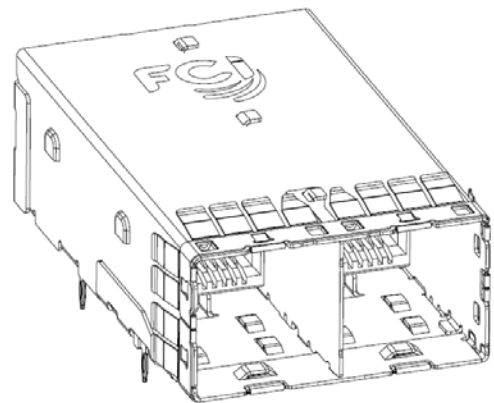

1X2 Configuration

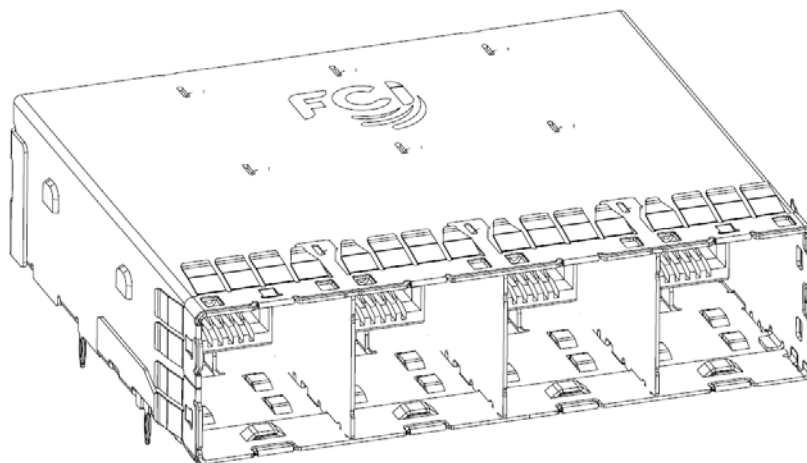

1X4 Configuration

Figure 1: Views of Product Configurations

NUMBER GS-20-0327	TYPE Application Specification		
TITLE Mini-SAS HD External Application Specification		PAGE 5 of 18	REVISION C
		AUTHORIZED BY M. Scholeno	DATE 2012-6-28
CLASSIFICATION UNRESTRICTED			

4.3 KEYING FEATURES

The Mini-SAS HD external board connector has a primary and secondary blocking key built into the cage assembly to aid in proper orientation of the cable connector during mating. See Figure 2 for views of the blocking keys.

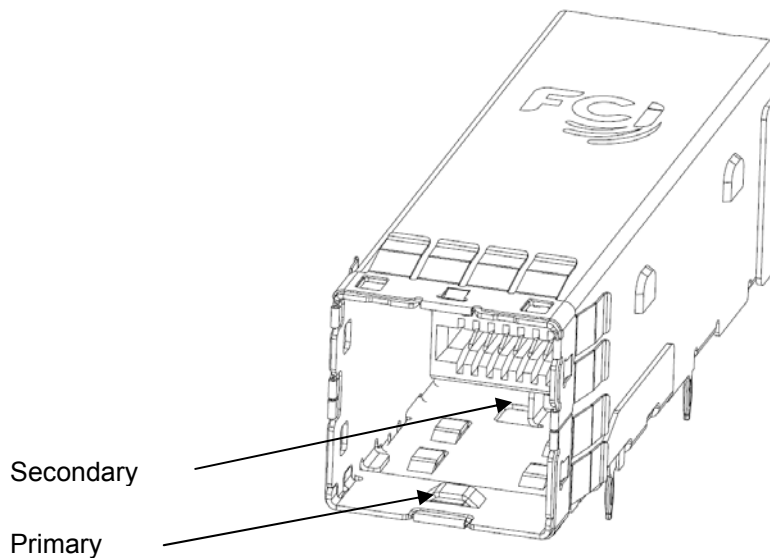
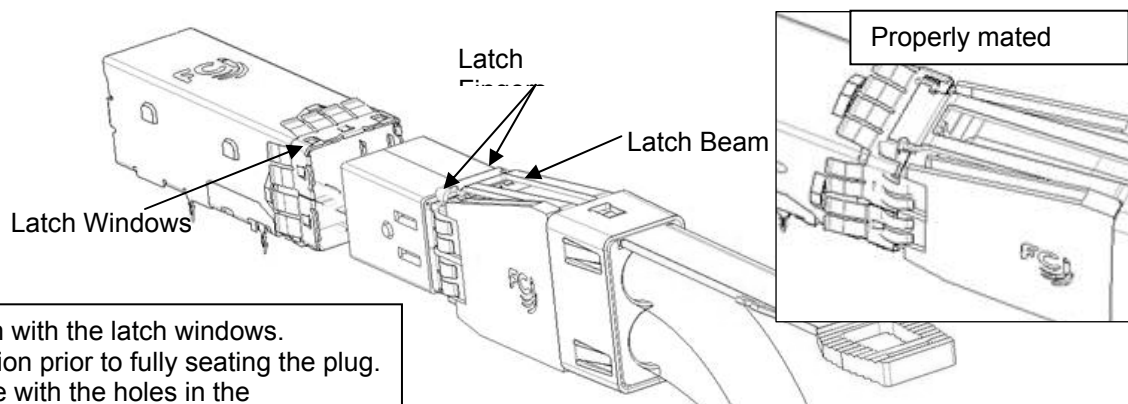

Figure 2: View of Blocking Keys (1x1 configuration shown)

4.3.1 MATING OF THE PLUG

Care should be taken when mating the cable plug to the connector. Although the specification defined key features are present, it is possible to forcibly override these features. Forces greater than 30N should be avoided when inserting the plug. If the plug stops before being fully installed, confirm proper orientation prior to completing mating.

Proper orientation is achieved when the latch of the plug is aligned with the latch windows of the cage. The latch fingers shall be confirmed aligned with the holes prior to complete insertion.



Align latch beam with the latch windows. Confirm orientation prior to fully seating the plug. If latch not in line with the holes in the connector, rotate the plug and realign.

NUMBER GS-20-0327	TYPE Application Specification	FCI	
TITLE Mini-SAS HD External Application Specification		PAGE 6 of 18	REVISION C
		AUTHORIZED BY M. Scholeno	DATE 2012-6-28
		CLASSIFICATION UNRESTRICTED	

4.4 PIN DESIGNATIONS AND USAGE

The Mini-SAS HD board connector utilizes a ground bussing system. All contacts in columns 3, 6, and 9 (A3, B3, C3, D3, A6, B6, C6, D6, A9, B9, C9, & D9) must be designated as ground terminals. All other contact positions may be used for signals. See figure 3 for pin designations.

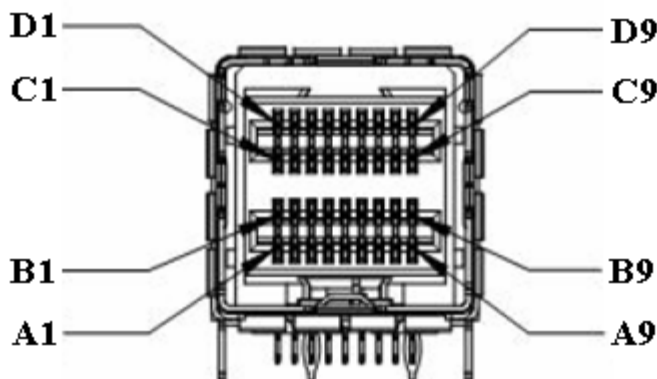

Figure 3: View of Pin Designations

5.0 PCB REQUIREMENTS

5.1 BOARD LAYOUT

Refer to the applicable FCI product customer drawing for the connector footprint layout.

5.2 BOARD THICKNESS

A minimum board thickness of 1.57 millimeters is required for the press-fit termination. There is no maximum board thickness requirement for either application.

5.3 CONNECTOR TO CONNECTOR SPACING

When stacking connectors side by side on a PCB it is recommended to keep a minimum 13.25 millimeter distance between the centerline of the adjacent ports. See figure 4 for an example of minimum spacing.

NUMBER GS-20-0327	TYPE Application Specification		
TITLE Mini-SAS HD External Application Specification		PAGE 7 of 18	REVISION C
		AUTHORIZED BY M. Scholeno	DATE 2012-6-28
		CLASSIFICATION UNRESTRICTED	

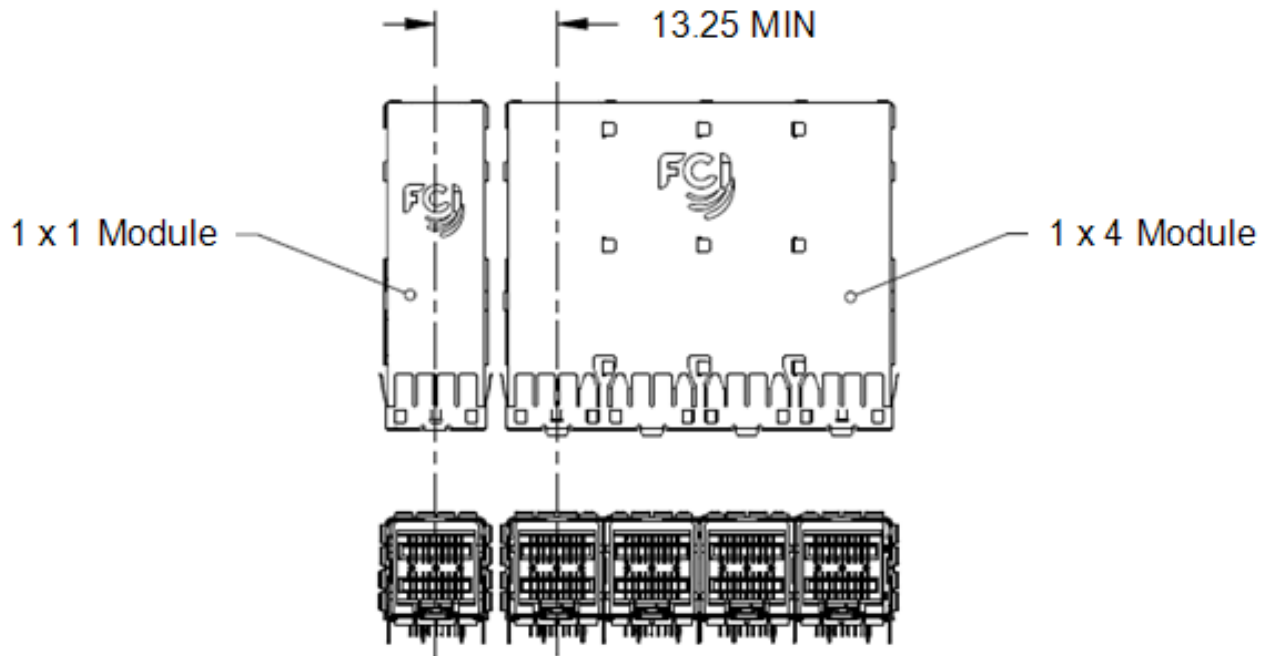

Figure 4: Example of Minimum Connector to Connector Spacing

NUMBER GS-20-0327	TYPE Application Specification	FCI	
TITLE Mini-SAS HD External Application Specification		PAGE 8 of 18	REVISION C
		AUTHORIZED BY M. Scholeno	DATE 2012-6-28
		CLASSIFICATION UNRESTRICTED	

5.4 BACK DRILLING

Back drilling is a method used by system designers to improve high speed signal integrity performance by reducing the stub length of a conductive via. When back drilling is performed, it is important to avoid damaging the portion of the via that contacts the press-fit tail. After the back drilling operation the remaining via barrel length for the press fit tails on the connector must be at least 1.0mm minimum in order to ensure a reliable connection between the press-fit section and the PCB. See figure 5 below for more recommendations on proper back drilling.

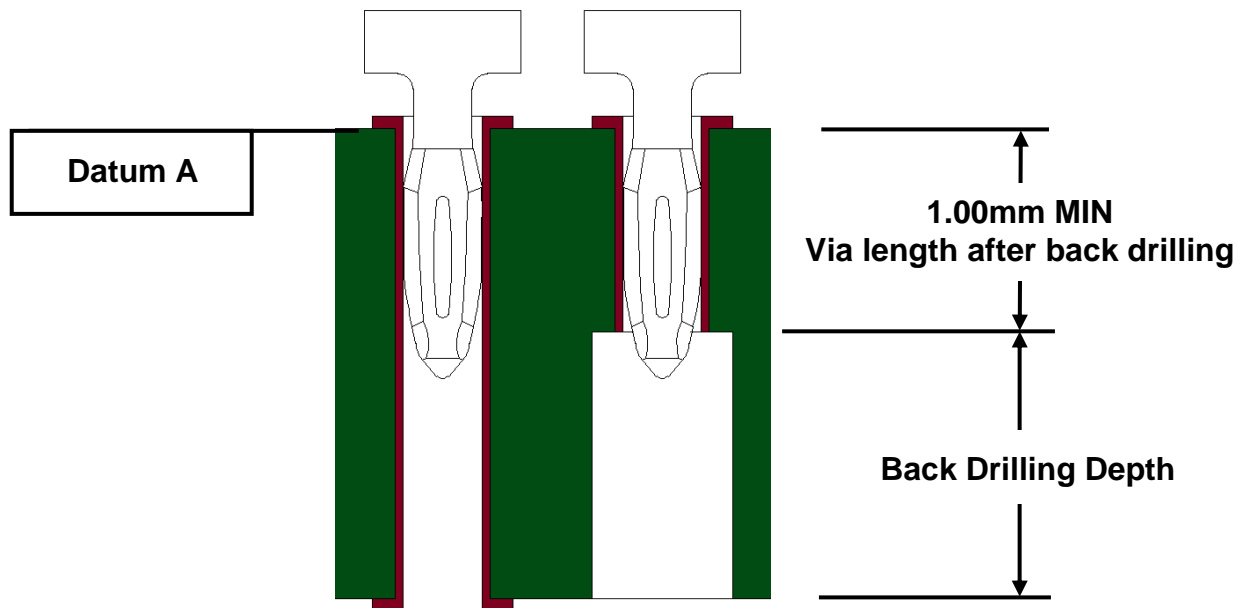



Figure 5: View of Back Drilling

5.5 KEEP-OUT ZONES FOR APPLICATION AND REMOVAL TOOLING:

Keep out zones outside the envelope of the connector are required for both the insertion and removal tools. Refer to the applicable FCI product customer drawing for the details pertaining to the keep out zone requirements.

NUMBER GS-20-0327	TYPE Application Specification		
TITLE Mini-SAS HD External Application Specification		PAGE 9 of 18	REVISION C
		AUTHORIZED BY M. Scholeno	DATE 2012-6-28
		CLASSIFICATION UNRESTRICTED	

5.6 BREAKOUT RECOMMENDATION:

TRACE GEOMETRY

- Differential Trace Dimensions: 3/4/3
- Relative Dielectric Range: 3.6 to 4.4
- Copper weight: 0.5 oz

Using the recommended anti-pad geometry shown below, ground will be above and below the signal traces, providing an adequate return path for high speed signaling.

SIGNAL LAYER STACK-UP

- Above trace: 7mil core
- Below trace: 6mil pre-preg

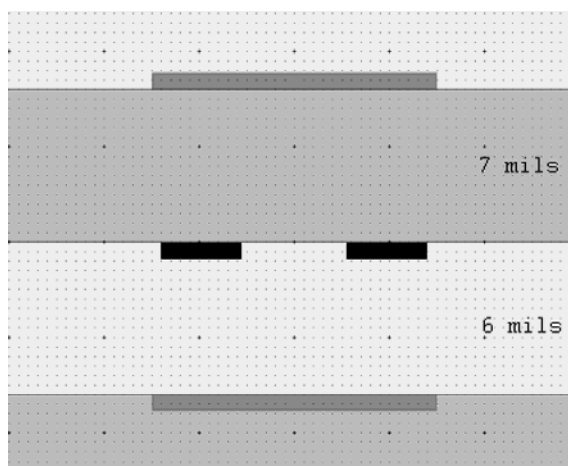

ANTI PAD GEOMETRY

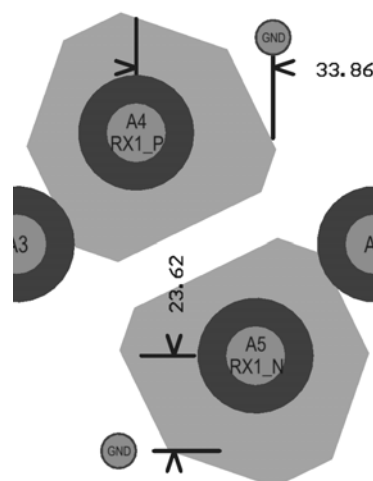
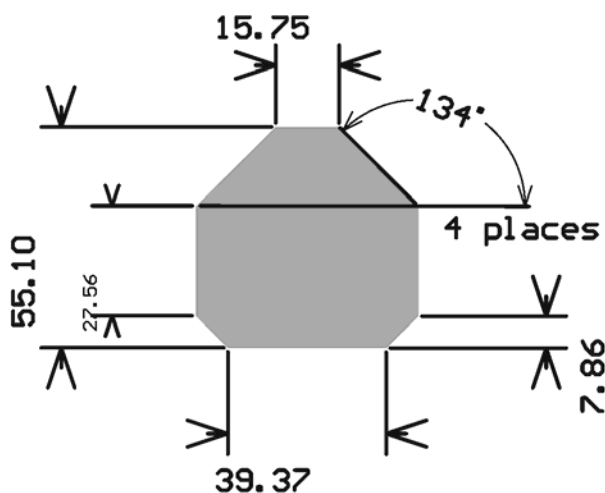



NUMBER GS-20-0327	TYPE Application Specification		
TITLE Mini-SAS HD External Application Specification		PAGE 10 of 18	REVISION C
		AUTHORIZED BY M. Scholeno	DATE 2012-6-28
CLASSIFICATION UNRESTRICTED			

ANTIPAD GEOMETRY CONT.

- Recommended Anti-Pad angle: 30°
 - The angle of the anti-pad adjusts the trace angle departure.
- Recommended Pinning Hole size: ≤ 8 mils
 - The pinning via can be any size that does not interfere with the differential traces.

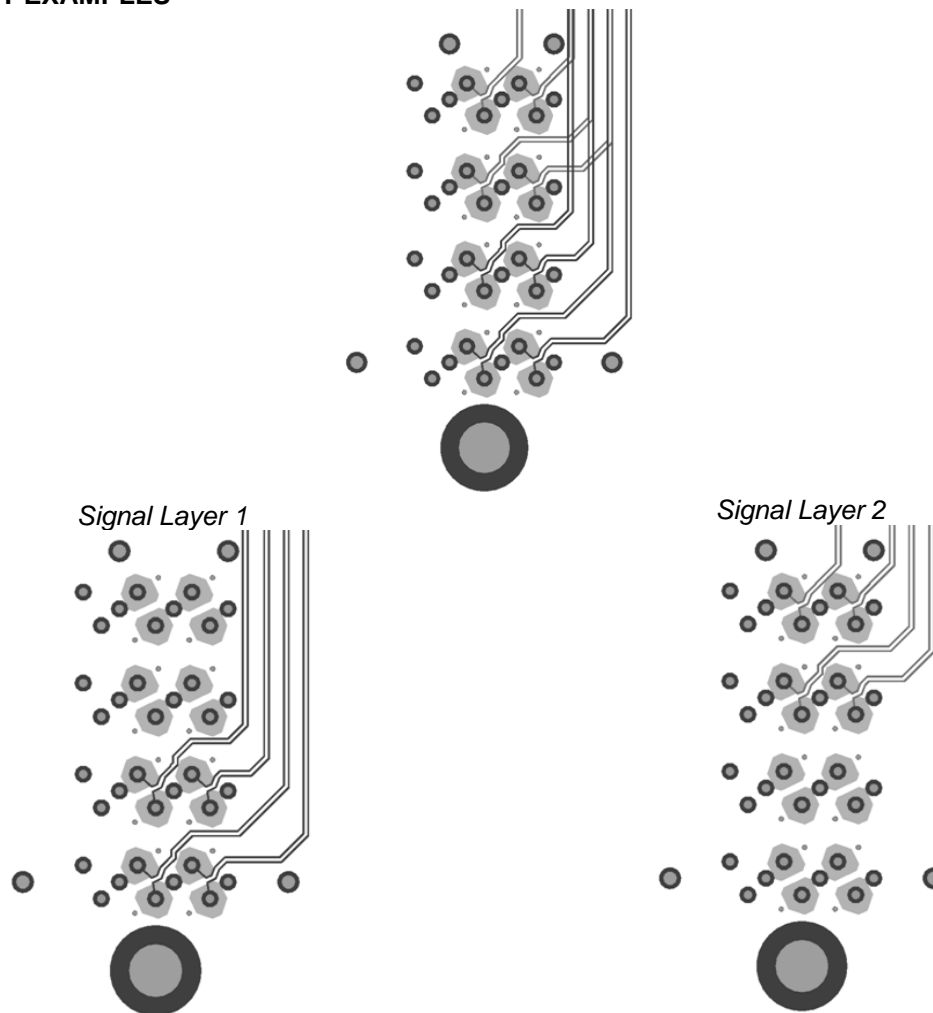
BREAK OUT EXAMPLES



NUMBER GS-20-0327	TYPE Application Specification		
TITLE Mini-SAS HD External Application Specification		PAGE 11 of 18	REVISION C
		AUTHORIZED BY M. Scholeno	DATE 2012-6-28
CLASSIFICATION UNRESTRICTED			

6.0 APPLICATION TOOLING

6.1 CONNECTOR INSERTION TOOLING

The application tools recommended for the Mini-SAS HD External board connectors are shown in Table 2. A special bottom support tool will be necessary if the connector's tails are longer than the thickness of the PCB that the connector is being applied to (the tail length specification for the cage is 2.10mm \pm 0.13mm). The bottom support tool could be a PCB with oversized holes or a custom tool designed by the user.

Insertion Tool P/N	Description
10118556	Insertion tool for 1X1 External Assembly (Connector series 10112626)
10118557	Insertion tool for 1X2 External Assembly (Connector series 10112627)
10118558	Insertion tool for 1X4 External Assembly (Connector series 10112628)

Table 2: Insertion Tooling Part Numbers

6.2 INSERTION PRESSES

Several important items to consider when selecting an insertion press include:

- The press must have sufficient force capabilities to insert the specific receptacle configuration.
- The press ram should be sufficiently long to cover the Press Block tooling to prevent tooling flex.
- The press table should be large enough to properly accommodate the PCB size.

Typical press types include:

- Manual arbor press
- Pneumatic press
- Hydraulic press
- Servo driven electronic press

Although the connector can be applied using any of the press types mentioned above the preferred press type is the servo driven electronic press. This press gives the best control during the insertion process and offers the most flexibility.

7.0 RECOMMENDED INSERTION FORCES

The recommended maximum insertion force is 18 Newton per press-fit pin. The maximum insertion force per connector is found by taking the total number of contacts in the connector assembly and multiplying it by the 18 N maximum requirement. Refer to the example below.

NUMBER GS-20-0327	TYPE Application Specification	FCI	
TITLE Mini-SAS HD External Application Specification		PAGE 12 of 18	REVISION C
		AUTHORIZED BY M. Scholeno	DATE 2012-6-28
CLASSIFICATION UNRESTRICTED			

EXAMPLE: For a 1X1 receptacle assembly there are 42 press-fit tails being inserted into the PC board. Therefore, the maximum recommended press setting would be 756 N (42 press-fit tails x 18 N).

This maximum force recommendation has been determined to yield acceptable insertion results for PCB holes within FCI's recommended guidelines. While it is acceptable to use a lower insertion force per press-fit pin, steps should be taken to guarantee that the connector is seated properly (see Section 9). Force settings may vary with different types of PTH finishes. Customers should develop parameters that best suit individual application requirements.

8.0 APPLICATION PROCEDURE

The application procedure for the Mini-SAS HD connector assembly is as follows:

- Place the connector assembly in the desired location on the daughter card taking care to assure that all press-fit tails line up with the proper holes.

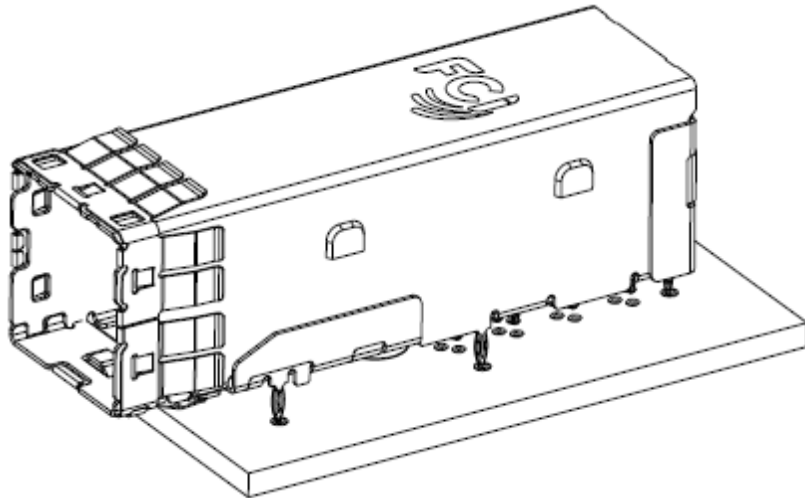

- Place the proper insertion tool (refer to section 6.1) on top of the connector assembly as shown in the figure below. The tool should rest flat on the top surface of the connector and the lip of tool should be placed against the back of the connector. Apply force to the flat surface of the insertion tool. Actuation of the press should be slow and controlled, not fast like a punch press. Inserting to a specified force will yield more consistent results than inserting to a set distance. To ensure proper insertion, connectors must be centered beneath the press ram. An offset in the loading may result in improper seating of the connector.

NUMBER GS-20-0327	TYPE Application Specification		
TITLE Mini-SAS HD External Application Specification		PAGE 13 of 18	REVISION C
		AUTHORIZED BY M. Scholeno	DATE 2012-6-28
		CLASSIFICATION UNRESTRICTED	

NUMBER GS-20-0327	TYPE Application Specification		
TITLE Mini-SAS HD External Application Specification		PAGE 14 of 18	REVISION C
		AUTHORIZED BY M. Scholeno	DATE 2012-6-28
		CLASSIFICATION UNRESTRICTED	

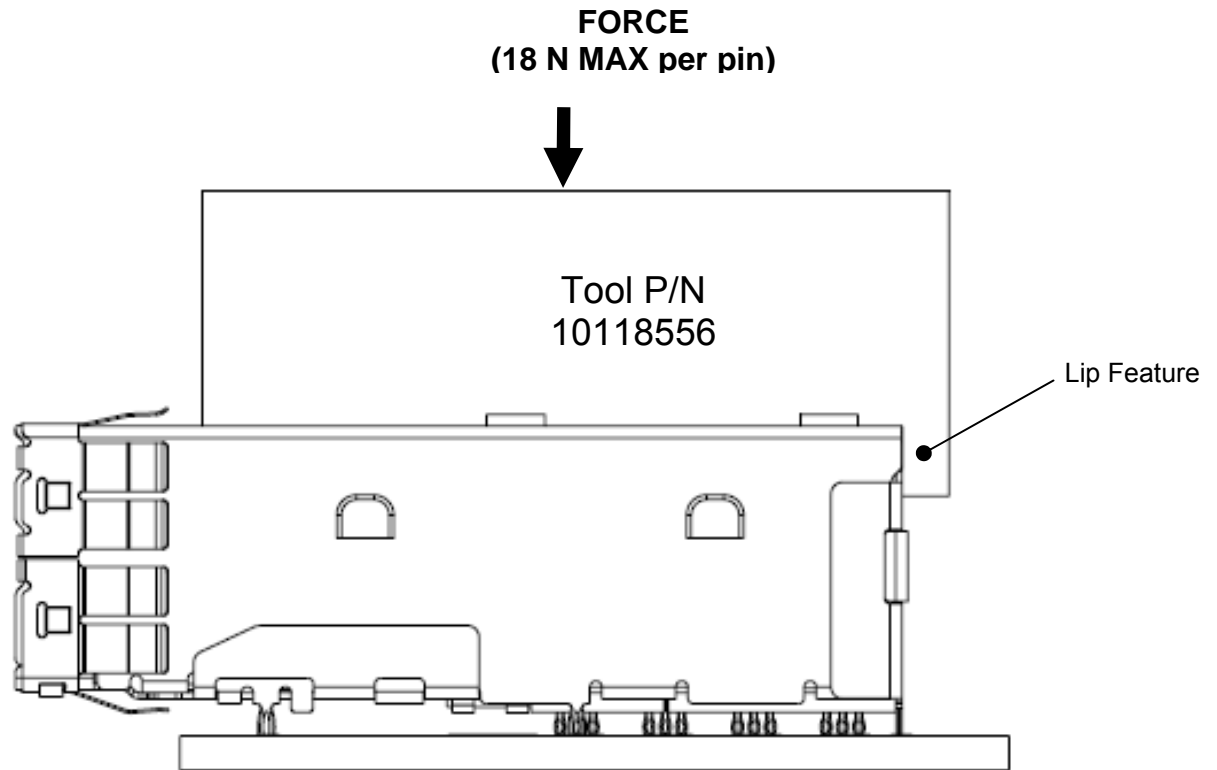

- Remove the assembled board and inspect the connector for proper application (refer to section 9.0).

9.0 POST-APPLICATION INSPECTION PROCEDURES

The Post-application inspection should consist of several simple checks to assure that the connector is applied properly and is not damaged.

- Visually assure that all press-fit tails are seated in the proper PCB holes and that none have been crushed during application.
- Visually assure that the metal standoffs on the bottom of cage assembly are seated flush to no greater than 0.08 mm away from the top of the PCB surface. A larger gap beneath the standoffs may indicate that the connector is not fully seated or is not seated parallel to the board. This can lead to assembly issues with the panel opening, or even problems with mating.

NUMBER GS-20-0327	TYPE Application Specification		
TITLE Mini-SAS HD External Application Specification		PAGE 15 of 18	REVISION C
		AUTHORIZED BY M. Scholeno	DATE 2012-6-28
		CLASSIFICATION UNRESTRICTED	

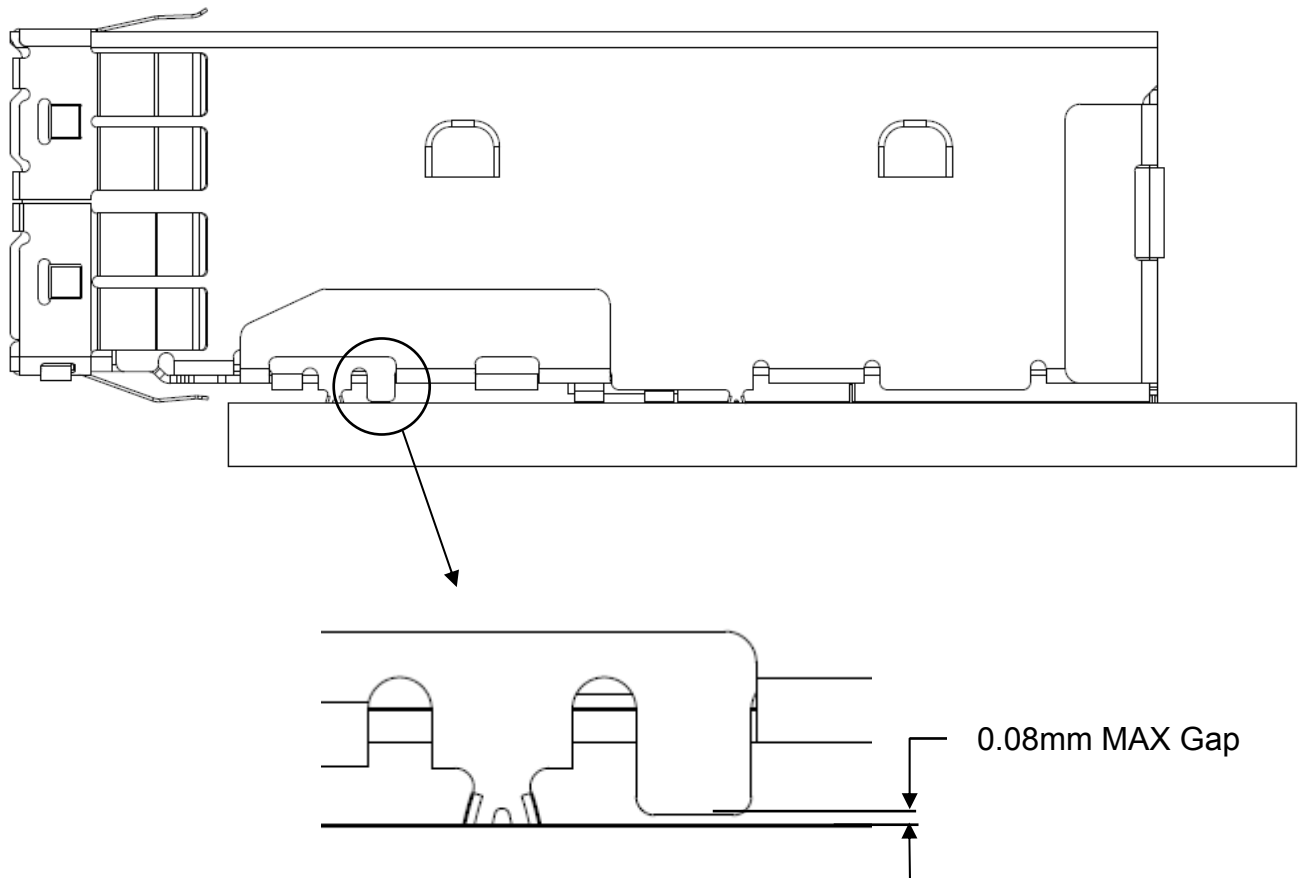



Figure 6: Proper Seating after Board Application

10.0 MOUNTING SCREWS

The cage assembly is equipped with a M2 x 0.4 threaded nut for attachment to the PCB. The screw mounts help retain the connector onto the PCB and also provides strain relief for the press-fit terminals on the connector and the cage. For multiport assemblies, each port has a threaded nut. In other words a dual port configuration (1X2) has 2 nuts per assembly, and a four port configuration (1X4) contains 4 nuts per assembly. The proper screw length needed for an application shall be determined by adding the PCB thickness plus an additional length of 0.9 (minimum) to 1.4 (maximum) millimeters. Screws should be fastened to a maximum torque specification of 1.5 inch-pounds. Do not over torque the screws as this could cause damage to the assembly.

NUMBER GS-20-0327	TYPE Application Specification		
TITLE Mini-SAS HD External Application Specification		PAGE 16 of 18	REVISION C
		AUTHORIZED BY M. Scholeno	DATE 2012-6-28
		CLASSIFICATION UNRESTRICTED	

M2 X 0.4 Threaded Nut

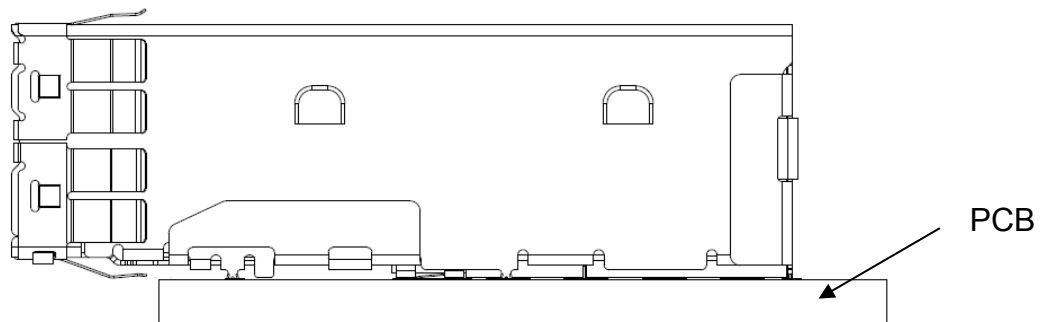
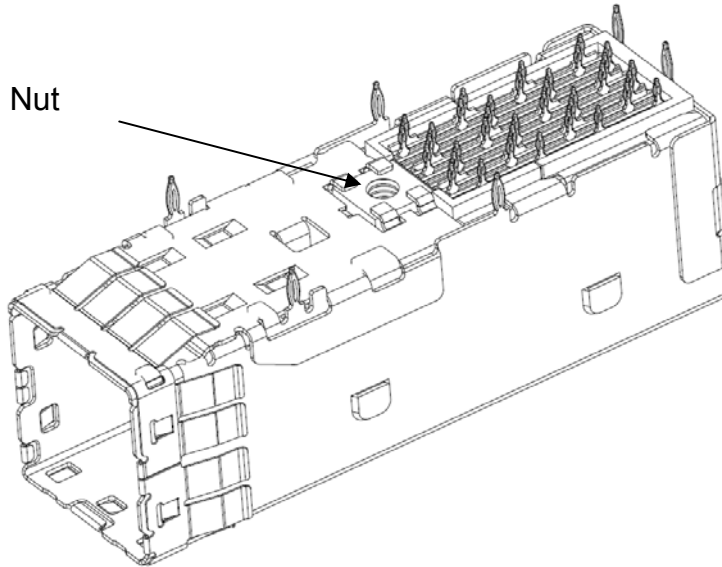

M2 X 0.4 Mounting Screw

11.0 PANEL MOUNTING

The connector is designed to be inserted into the panel opening after it has been pressed onto the PCB and secured with the proper screw attachment. After inserting the connector into the panel opening, inspect the connector to make sure that it is centered within the opening. Also, inspect the EMI Springs on all four sides of the cage to make sure that they are compressed against the panel.

NUMBER GS-20-0327	TYPE Application Specification		
TITLE Mini-SAS HD External Application Specification		PAGE 17 of 18	REVISION C
		AUTHORIZED BY M. Scholeno	DATE 2012-6-28
CLASSIFICATION UNRESTRICTED			

11.1 PANEL OPENING

Refer to the applicable FCI product customer drawing for the dimensions of the panel opening.

11.2 PANEL THICKNESS

For normal mounting applications the panel thickness is to be between 1.00 to 1.70 millimeters. For PCI applications the PCI bracket thickness is to be between 0.86 to 1.11 millimeters with a maximum panel thickness of 1.32 millimeters.

12.0 REPAIR TOOLING

Tool PN	Tool Description	Connector PN	Connector Description
10119082-1000	Removal Tool (FCI MANUAL P/N 10119082-9090)	10112626	Mini-SAS HD 1x1 External
		10112627	Mini-SAS HD 1x2 External
		10112628	Mini-SAS HD 1x4 External
10118556	Insertion Tool	10112626	Mini-SAS HD 1x1 External
10118557		10112627	Mini-SAS HD 1x2 External
10118558		10112628	Mini-SAS HD 1x4 External

Refer to removal tool manual 10119082-9090 for detailed instructions on how to properly remove a connector with this tool.

Refer to section 8.0 for details on installing a new connector.

Connectors must be replaced if removed from the PCB. Connectors may be removed for the PCB up to two times and the PCB may sustain a third connector application. This may vary with board and PTH construction. Plated holes should be inspected to ensure no detrimental degradation has occurred.

If repairs to the PCB require soldering while the connector is mounted to the PCB; after soldering, remove fluxes, residues, and activator. Follow the procedures and use solvents recommended by the solder and flux manufacture. Cleaners must be free of dissolved flux and other contaminants. When removing a “no clean” solder paste residue; it is critical that the connector contact interface be kept clean of flux and residue.



NUMBER GS-20-0327	TYPE Application Specification		
TITLE Mini-SAS HD External Application Specification		PAGE 18 of 18	REVISION C
		AUTHORIZED BY M. Scholeno	DATE 2012-6-28
CLASSIFICATION UNRESTRICTED			

13.0 RECORD RETENTION

REV	PAGE	DESCRIPTION	EC #	DATE
A	All	Release	-	2012-2-1
B		Add Breakout, Repair and clean-up format	ELX-V-011073	2012-3-27
C		Add Plug instructions	ELX-V-012050	2012-6-28