

THIS DRAWING IS UNPUBLISHED. RELEASED FOR PUBLICATION
 © COPYRIGHT - By - ALL RIGHTS RESERVED.

LOC	DIST	REVISIONS					
GP	00	P	LTR	DESCRIPTION	DATE	DWN	APVD
		H1		ECR-11-025464	16DEC11	RK	BVH

NOTES:

- ⚠ PITCH TOLERANCE TO BE ±.18[.007] FOR 1.27[.050] PITCH JUMPERS & ±.25[.010] FOR ALL REMAINING PITCHES. TOLERANCE TO BE NON CUMULATIVE OVER GAUGE LENGTH.
- ⚠ 11.92-152.40[.500-6.000] ARE STANDARD LENGTHS. JUMPERS ARE AVAILABLE IN INCREMENTS OF 2.50[.10] PLUS 6.35[.25] AND 19.05[.75].
- ⚠ DELETED
- ⚠ FOR CONDUCTOR PITCH 7 (2mm), ON PAGE 2 & 3, DIMENSION "B" IS 2.00[.079]
- ⚠ SPECIAL PIN LENGTHS ARE AVAILABLE FOR JUMPERS WITH A PIN CONFIGURATION OF "A" OR "B" ON LENGTHS OF UP TO 609.6[24.0] IN 2.54[.100] & 5.08[.200] PITCH VARIANTS ONLY BY ADDING THE FOLLOWING SUFFIXES:

SUFFIX	PEN LENGTH	TOLERANCE
V1	2.85 (.112)	±.305 [±.012]
V2	3.40 (.134)	
V3	4.10 (.161)	
V4	6.50 (.256)	
V5	3.10 (.122)	
V6	2.81 (.150)	
V7	4.50 (.177)	
V8	2.00 (.079)	
V9	TBD	
V10	.76 (.030)	
V11	2.41 (.095)	



6. RECOMMENDED PCB HOLE DRILLING DETAILS ARE AS FOLLOWS:-

PITCH A	ØG
1.27 (.050)	.70 (.028)
1.90 (.075)	.80 (.031)
2.54 (.100)	.95 (.037)
3.18 (.125)	.95 (.037)
3.81 (.150)	.95 (.037)
5.08 (.200)	.95 (.037)



JUMPER LENGTH	PITCH (NOMINAL)	TRANSITION MAX	MAX/MIN MARGIN	△ PIN DIAMETER	WIRE GAUGE (AWG)	MIN/MAX No OF CONDUCTORS	MAXIMUM ADHESIVE FLOW	MIN GAP BETWEEN CONDUCTORS	CONDUCTOR WIDTH	MAXIMUM INSULATION MISMATCH	MAX THICKNESS
R	A	T	C	E	-	-	V	X	Y	Z	D
11.93 (.50) TO 863.6 (30.00) IN STEPS OF 2.50 (.10) PLUS 6.35 (.25) AND 19.05 (.75)	1.00 (0.039)	4.32 [.170]	0.35 (0.014) 0.17 (.007)	0.330 (.0130) 0.317 (.0125)	28	2-70	0.38 (0.015)	0.13 (0.009)	0.76 (.030) 0.56 (.022)	.76 (.030)	.64
	1.25 (0.049)	4.32 [.170]	0.50 (0.020) 0.17 (0.007)	0.330 (.0130) 0.317 (.0125)	28	2-70	0.38 (0.015)	0.25 (0.010)	0.89 (.035) 0.64 (.025)	.76 (.030)	.64
	1.27 (0.050)	4.32 [.170]	0.50 (0.020) 0.17 (0.007)	0.330 (.0130) 0.317 (.0125)	28	2-70	0.38 (0.015)	0.25 (0.010)	0.89 (.035) 0.64 (.025)	.76 (.030)	.64
	2.00 (0.079)	5.08 [.200]	0.70 (0.028) 0.25 (0.010)	0.416 (0.0164) 0.400 (0.0157)	26	2-50	0.38 (0.015)	0.38 (0.015)	1.14 (.045) 0.89 (.035)	.76 (.030)	.84
	1.90 (0.075)	5.08 [.200]	0.70 (0.028) 0.25 (0.010)	0.416 (0.0164) 0.400 (0.0157)	26	2-50	0.38 (0.015)	0.38 (0.015)	1.14 (.045) 0.89 (.035)	.76 (.030)	.84
	2.54 (0.100)	6.35 [.250]	0.80 (0.031) 0.25 (0.010)	0.526 (0.0207) 0.505 (0.0199)	24	2-50	0.51 (0.020)	0.51 (0.020)	1.52 (.060) 1.27 (.050)	.76 (.030)	.84
	3.18 (0.125)	6.35 [.250]	1.00 (0.039) 0.25 (0.010)	0.526 (0.0207) 0.505 (0.0199)	24	2-25	0.51 (0.020)	0.51 (0.020)	1.52 (.060) 1.27 (.050)	.76 (.030)	.84
	3.81 (0.150)	6.35 [.250]	1.00 (0.039) 0.25 (0.010)	0.526 (0.0207) 0.505 (0.0199)	24	2-20	0.51 (0.020)	0.51 (0.020)	1.52 (.060) 1.27 (.050)	.76 (.030)	.84
	5.08 (0.200)	6.35 [.250]	1.00 (0.039) 0.25 (0.010)	0.526 (0.0207) 0.505 (0.0199)	24	2-15	0.51 (0.020)	0.51 (0.020)	1.52 (.060) 1.27 (.050)	.76 (.030)	.84

- ⚠ BEND RADIUS TO APPLY ONLY IN THE FLAT SECTION OF JUMPER BETWEEN THE CONDUCTOR TRANSITION AREAS.
- ⚠ PER 108-2135.
- 9. TOOL MARKS PERMISSIBLE ON BENDS. NO EXPOSED COPPER.
- ⚠ PIN DIAMETER SPECIFIED NOT APPLICABLE IN BENDING AREA OF PIN, DUE TO NORMAL DEFORMATION OF BENDING PROCESS.
- ⚠ REFER TO RELEVANT MATERIAL SPECIFICATIONS.

F - MID POINT THICKNESS BETWEEN PT 1 & PT 2	MINIMUM	MAXIMUM
	NOMEX®	.152 [.006]
POLYESTER	.152 [.006]	.305 [.012]
KAPTON®	.102 [.004]	.254 [.010]
TEFLON®	.305 [.012]	.533 [.021]

12. PRODUCT AND PROCESSING MUST MEET REQUIREMENTS OF TE CONNECTIVITY STANDARD 230-702.

Nomex®, Teflon® and Kapton® are trademarks of E. I. DuPont de Nemours.

THIS DRAWING IS A CONTROLLED DOCUMENT.

DWN J. SCHWARTZ 28FEB01
 CHK E. FOX 28FEB01
 APVD E. FOX 28FEB01

STE TE Connectivity

FLEXSTRIP PIN CONFIGURATIONS, GENERIC

PRODUCT SPEC
 APPLICATION SPEC

SIZE A3 CAGE CODE 00779 DRAWING NO C-1474339 RESTRICTED TO -

SCALE N.T.S. SHEET 1 OF 4 REV H1

CUSTOMER DRAWING

THIS DRAWING IS UNPUBLISHED. RELEASED FOR PUBLICATION
 © COPYRIGHT - By - ALL RIGHTS RESERVED.

LOC GP DIST 00

P		LTR	DESCRIPTION	DATE	DWN	APVD
		-	SEE SHEET 1	-	-	-

A - STRAIGHT PINS



B - RIGHT ANGLE PINS (BENT DOWN)

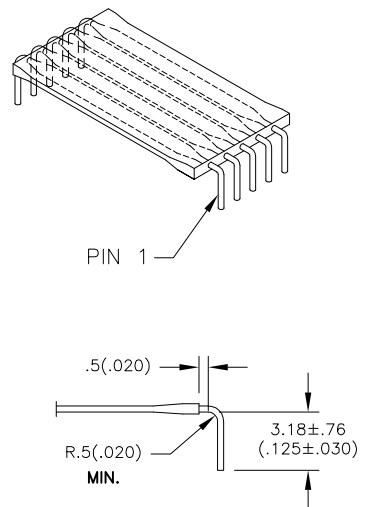

C - RIGHT ANGLE STAGGERED PINS (PIN 1 SHORT, BENT DOWN)

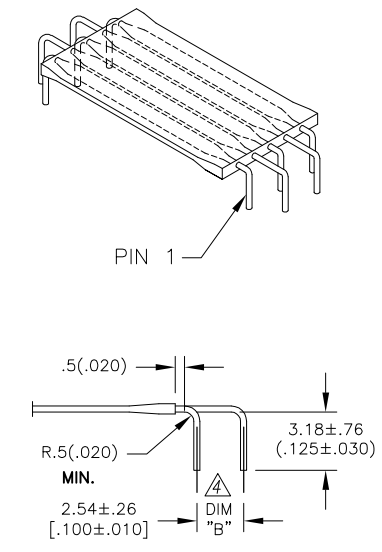

D - STRAIGHT ANGLE STAGGERED PINS (PIN 1 STRAIGHT)

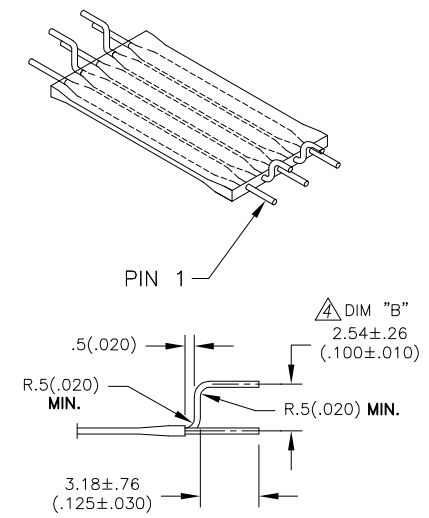

STANDARD JUMPERS
SMART DESCRIPTION



MANUFACTURING NOTE:
MINIMUM GAP BETWEEN STRIPS

SK/A/Z	.75 INCH
LP	1.1 INCH

MINIMUM CONDUCTOR COUNT
PER STRIP FOR LINE JOBS

PITCH	CONDUCTOR
1 1.27 (.050)	60
2 2.54 (.100)	60
3 3.18 (.125)	60
4 3.81 (.150)	50
5 5.08 (.200)	40
6 1.91 (.075)	60
7 2.0 (.078)	60
8 1.24 (.049)	60
9 1.0 (.039)	80

STANDARD LINE JOBS

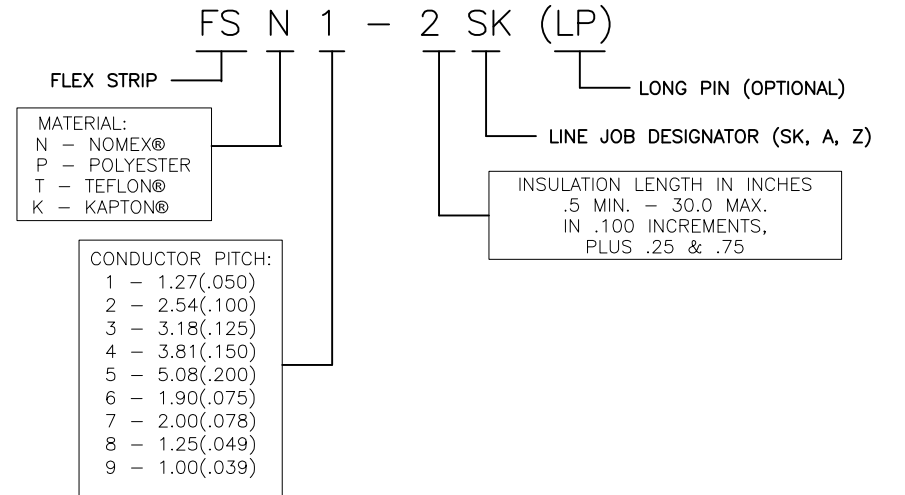

THE FOLLOWING ORDERING CODE IS A SPECIAL FOR TE CONNECTIVITY GERMANY DESCRIBING A STRIP OF ANY INSULATION MATERIAL, ANY PITCH AND ANY INSULATION LENGTH WITH A 11.00[.433] MIN PIN LENGTH UNLESS OTHERWISE SPECIFIED:-

FS X-X X J-A A W

Nomex®, Teflon® and Kapton® are trademarks of E. I. DuPont de Nemours.

THIS DRAWING IS A CONTROLLED DOCUMENT.

DIMENSIONS: MM [INCHES]	TOLERANCES UNLESS OTHERWISE SPECIFIED:
	0 PLC ± -
	1 PLC ± -
	2 PLC ± -
	3 PLC ± -
	4 PLC ± -
	ANGLES ± 1/2°
MATERIAL	FINISH
-	-

DWN	J. SCHWARTZ	28FEB01
CHK	E. FOX	28FEB01
APVD	E. FOX	28FEB01
PRODUCT SPEC	-	-
APPLICATION SPEC	-	-
WEIGHT	-	-

TE Connectivity		NAME		RESTRICTED TO
		FLEXSTRIP PIN CONFIGURATIONS, GENERIC		
SIZE	CAGE CODE	DRAWING NO	-	
A3	00779	C-1474339	-	
CUSTOMER DRAWING		SCALE	SHEET	REV
		N.T.S.	2 OF 4	H1

THIS DRAWING IS UNPUBLISHED. RELEASED FOR PUBLICATION
 © COPYRIGHT - By - ALL RIGHTS RESERVED.

LOC	DIST	REVISIONS					
GP	00	P	LTR	DESCRIPTION	DATE	DWN	APVD
		-		SEE SHEET 1	-	-	-

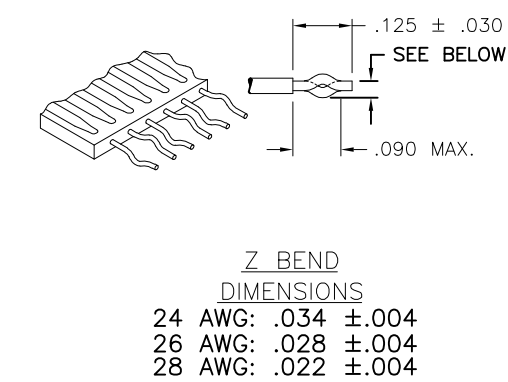
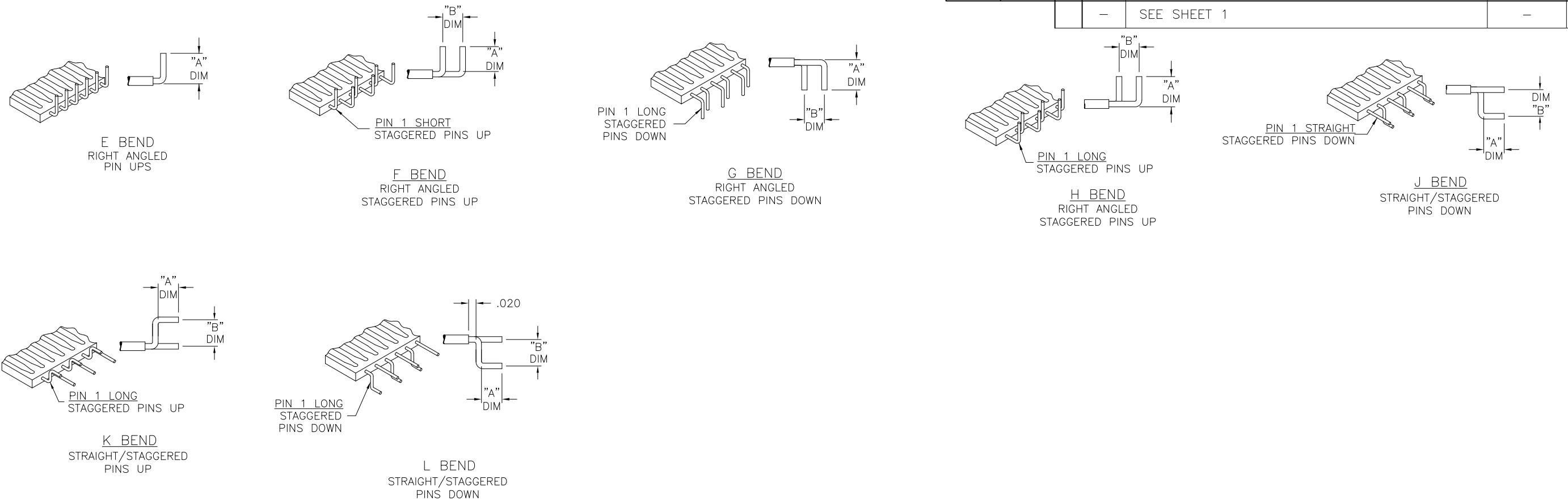

SPECIAL JUMPERS SMART DESCRIPTION

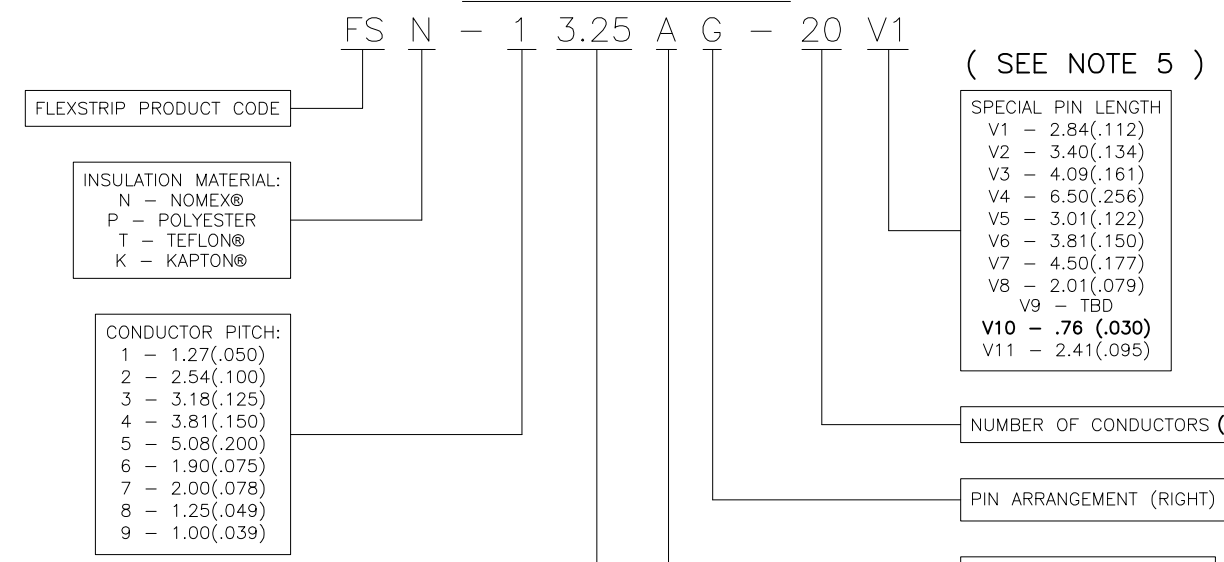

CONDUCTOR PITCH	BENDS AVAILABLE
1 - 1.27/(.050)	E,F,G,H,J,K,L
2 - 2.54/(.100)	E,F,G,H,J,K,L
3 - 3.18/(.125)	E
4 - 3.81/(.150)	E
5 - 5.08/(.200)	E
6 - 1.91/(.075)	E,F,G,H,J,K,L
7 - 2.00/(.0787)	E,F,G,H,J,K,L
8 - 1.25/(.049)	E
9 - 1.00/(.039)	E

E THRU L BEND
"A" DIM
3.18±0.76/(.125±.030)
"B" DIM
2.54±0.25/(.100±.010)

SPECIAL FLEXSTRIP BENDS
 SPECIAL FLEXSTRIP BENDS E THRU R, AND Z MAY APPLY TO EITHER LEFT OF RIGHT SIDE

INSULATION LENGTH: (in inches)
 .50 MIN. - 30.0 MAX.
 IN .10 INCREMENTS PLUS .25 AND .75

Nomex®, Teflon® and Kapton® are trademarks of E. I. DuPont de Nemours.

THIS DRAWING IS A CONTROLLED DOCUMENT.		DWN	J. SCHWARTZ	28FEB01	 TE Connectivity	NAME			RESTRICTED TO		
DIMENSIONS: MM [INCHES]		CHK	E. FOX	28FEB01		FLEXSTRIP PIN CONFIGURATIONS, GENERIC					
TOLERANCES UNLESS OTHERWISE SPECIFIED:		APVD	E. FOX	28FEB01		-					
0 PLC ± - 1 PLC ± - 2 PLC ± - 3 PLC ± - 4 PLC ± - ANGLES ± 1/2°		PRODUCT SPEC		-							
MATERIAL		APPLICATION SPEC		SIZE		CAGE CODE	DRAWING NO	-			
-		-		-		A300779	C-1474339	-			
FINISH		WEIGHT		CUSTOMER DRAWING		SCALE	N.T.S.	SHEET	3 OF 4	REV	H1
-		-		-		-		-		-	

THIS DRAWING IS UNPUBLISHED. RELEASED FOR PUBLICATION
 © COPYRIGHT - By - ALL RIGHTS RESERVED.

LOC GP	DIST 00	REVISIONS		
P	LTR	DESCRIPTION	DATE	DWN
		SEE SHEET 1	-	-

NORMAL CONDUCTOR PITCH		1.00 (.039)	1.25 (.049)	1.27 (.050)	1.90 (.075)	2.00 (.078)	2.54 (.100)	3.18 (.125)	3.81 (.150)	5.08 (.200)
WIRE GAUGE		AWG 28	AWG 28	AWG 28	AWG 26	AWG 26	AWG 24	AWG 24	AWG 24	AWG 24
NOMINAL WIRE DIAMETER		.32(.0126)	.32(.0126)	.32(.0126)	.40(.0159)	.40(.0159)	.51(.0201)	.51(.0201)	.51(.0201)	.51(.0201)
CURRENT RATING		8	8	8	8	8	8	8	8	8
VOLTAGE RATING		8	8	8	8	8	8	8	8	8
MAX NUMBER OF CONDUCTORS PER JUMPER		8	8	8	8	8	8	8	8	8
MIN BREAKDOWN VOLTAGE @ 1 MIN		8	8	8	8	8	8	8	8	8
INSULATION RESISTANCE (GND. SIG. GND) 305 (12") SAMPLE @ 500VDC	P N T K	8	8	8	8	8	8	8	8	8
CAPACITANCE (pf / 50.8 (12") LENGTH) (GND, SIG, GND) (AVERAGE)	P N T K	8	8	8	8	8	8	8	8	8
CHARACTERISTIC IMPEDANCE (GND. SIG. GND) (AVERAGE)	P N T K	8	8	8	8	8	8	8	8	8
APPLICATION TEMP RANGE (C°) (FOR SOLDERING)	P N T K	200 / 4 sec 200 / 4 sec 240 / 4 sec 240 / 4 sec	200 / 4 sec 200 / 4 sec 240 / 4 sec 240 / 4 sec	200 / 4 sec 200 / 4 sec 240 / 4 sec 240 / 4 sec	200 / 4 sec 200 / 4 sec 240 / 4 sec 240 / 4 sec	200 / 4 sec 200 / 4 sec 240 / 4 sec 240 / 4 sec	250 / 4 sec 250 / 4 sec 260 / 5 sec 260 / 5 sec	250 / 4 sec 250 / 4 sec 260 / 5 sec 260 / 5 sec	250 / 4 sec 250 / 4 sec 260 / 5 sec 260 / 5 sec	250 / 4 sec 250 / 4 sec 260 / 5 sec 260 / 5 sec
OPERATING TEMPERATURE (C°)	P N T K	-40 to 105 (For all Conductor Pitches) -40 to 125 (For all Conductor Pitches) -40 to 150 (For all Conductor Pitches) -40 to 150 (For all Conductor Pitches)								
MINIMUM BEND RADIUS	P N T K	3.18mm (For all Conductor Pitches) 3.18mm (For all Conductor Pitches) 3.18mm (For all Conductor Pitches) 3.18mm (For all Conductor Pitches)								
UL STYLE NUMBER	P N T K	2639 (For all Conductor Pitches .100 and above) 5456 (For all Conductor Pitches .100 and above) 2928 (For all Conductor Pitches .100 and above) 2927 (For all Conductor Pitches .100 and above)								

ABR.	MATERIAL	SPECIFICATION
	COPPER WIRE	100-1577
P	POLYESTER	100-1575
N	NOMEX®	100-1758
T	TEFLON®	100-1574
K	KAPTON®	100-1576

Nomex®, Teflon® and Kapton® are trademarks of E. I. DuPont de Nemours.

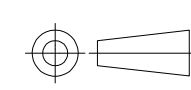
THIS DRAWING IS A CONTROLLED DOCUMENT.		DWN J. SCHWARTZ 28FEB01	 TE Connectivity	
		CHK E. FOX 28FEB01		
DIMENSIONS: MM [INCHES]		APVD E. FOX 28FEB01	NAME FLEXSTRIP PIN CONFIGURATIONS, GENERIC	
		PRODUCT SPEC -	-	
TOLERANCES UNLESS OTHERWISE SPECIFIED: 0 PLC ± - 1 PLC ± - 2 PLC ± - 3 PLC ± - 4 PLC ± - ANGLES ± 1/2°		APPLICATION SPEC -	-	
MATERIAL -		WEIGHT -	SIZE A3	CAGE CODE 00779
		FINISH -	DRAWING NO C-1474339	RESTRICTED TO -
CUSTOMER DRAWING			SCALE N.T.S.	SHEET 4 OF 4
			REV H1	