

## 0.8A SURFACE MOUNT GLASS PASSIVATED BRIDGE RECTIFIER

### Features

- Glass Passivated Die Construction
- Low Forward Voltage Drop
- Surge Overload Rating to 30A Peak
- Ideally Suited for Automatic Assembly
- Miniature Package Saves Space on PC Boards
- Plastic Material: UL Flammability Classification Rating 94V-0
- UL Listed Under Recognized Component Index, File Number E94661

### Mechanical Data

- Case: MiniDIP, Molded Plastic
- Terminals: Plated Leads, Solderable per MIL-STD-202, Method 2026
- Polarity: As Marked on Case
- Weight: 0.125 grams (approx.)
- Marking: Type Number

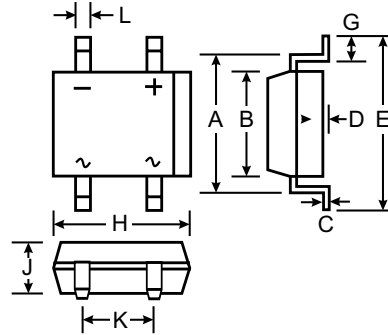

MiniDIP		
Dim	Min	Max
A	5.43	5.75
B	3.6	4.0
C	0.15	0.35
D	0.05	0.20
E	—	7.0
G	0.70	1.10
H	4.5	4.9
J	2.3	2.7
K	2.5	2.7
L	0.50	0.80
All Dimensions in mm		

### Maximum Ratings and Electrical Characteristics @ T<sub>A</sub> = 25°C unless otherwise specified

Single phase, 60Hz, resistive or inductive load.  
 For capacitive load, derate current by 20%.

Characteristic	Symbol	HD01	HD02	HD04	HD06	Unit
Peak Repetitive Reverse Voltage	V <sub>RMM</sub>	100	200	400	600	V
Working Peak Reverse Voltage	V <sub>RWM</sub>					
DC Blocking Voltage	V <sub>DC</sub>					
RMS Reverse Voltage	V <sub>RMS</sub>	70	140	280	420	V
Average Forward Rectified Current (Note 1) T <sub>A</sub> = @ 40°C	I <sub>O</sub>	0.8				A
Non-Repetitive Peak Forward Surge Current, 8.3 ms Single half-sine-wave Superimposed on Rated Load (JEDEC method)	I <sub>FSM</sub>	30				A
Instantaneous Voltage Drop @ 0.4A (per element)	V <sub>F</sub>	1.0				V
Peak Reverse Current at Rated DC Blocking Voltage (per element) @ T <sub>A</sub> = 25°C @ T <sub>A</sub> = 125°C	I <sub>R</sub>	5.0 500				μA
Typical Junction Capacitance (per element) (Note 2)	C <sub>j</sub>	10				pF
Typical Thermal Resistance, Junction to Ambient (Note 1)	R <sub>θJA</sub>	75				°C/W
Operating and Storage Temperature Range	T <sub>j</sub> , T <sub>STG</sub>	-55 to +150				°C

- Notes: 1. Mounted on Ceramic PC Board.  
 2. Measured at 1.0 MHz and Applied Reverse Voltage of 4.0 V.

